



2011 Harnish Blvd.
Billings, MT 59101

Phone: (406)656-4360/(800)523-3888
Fax: (406)656-4363

FAST-WAY LIMITED WARRANTY POLICY

Ideal Manufacturing, Inc., hereinafter referred to as “Manufacturer” warrants FAST-WAY equipment to be free from defect in material and workmanship, under normal use and service, for a period of one (1) year from the date of original purchase. Manufacturer will, at its option, replace or repair at factory in Billings, MT, any part or parts which shall appear, to the satisfaction of the Manufacturer, upon inspection at its factory, to have been defective in material or workmanship. This warranty does not obligate the Manufacturer to bear any transportation charges in connection with replacement or repair of defective parts. This warranty does not cover products or accessories that are not manufactured by Ideal Manufacturing, Inc. That product follows the warranty, and guidelines of that manufacturer. This warranty excludes electrical components and damage due to Acts of God, unauthorized modifications, misuse, abuse or negligence to this product.

In order to proceed with a warranty claim, Ideal Manufacturing must be notified of the problem. A new part will be shipped out prepaid (Ground UPS). If the customer requests that the part be expedited that shipping charge will be charged to the owner.

The part that is being warranted must be returned to Ideal Manufacturing postage prepaid. When the new part is shipped out, it will go out with an invoice and a warranty part return number. The defective part must be returned to Ideal Manufacturing, Inc freight prepaid, with the warranty part return number. At that time the invoice will be considered paid in full.

This warranty is exclusive and in lieu of all other obligation, liabilities or warranties. In no event shall Ideal Manufacturing be liable or responsible for incidental or consequential damage or for any other direct or indirect damage loss, cost, expense or fee.

This warranty shall not apply to any products or parts that have been altered or repaired without written consent of Ideal Manufacturing.

Labor to remove and reinstall defective product or parts will be paid from a labor rate and schedule only. Consult Ideal Manufacturing for that rate and schedule.

For further information on returning your product or questions concerning Ideal Manufacturing warranty, please contact Ideal Manufacturing.

Si-Low-206 H2

TABLE OF CONTENTS

DESCRIPTION	PAGE #
Si-Low 206-H2 Over View	1
Electrical Control Panel 440 volt 3 phase	2
Electrical Control Panel 240 volt 3 phase	3
Electrical Control Panel 240 volt Single phase	4
Electrical Connector for Towing	5
Main Component List	6
General Layout	7
Preparing Silo for Transport	8
Set Up Procedure	9
Safety Rules	10
Notes	11
Operating Procedure	12,13
Hydraulic System Electric Motor	14,15
Hydraulic System Gas & Diesel Engine	16,17
Auger Drive Assembly with Guard	18,19
Slide Gate to Auger	20
Auger Upper Bearing Assembly	21
Optional Control System for Electric Motor	22
Silo Baghouse	23
Baghouse Assembly	24,25
Adjustable Legs & Optional Load Cells	26,27
Trailer Wheel Components	28
Man Hole	29
Vibrator & Aeration System	30
Optional Control System for Gas & Diesel Engines	31
Vibrator & Optional Pulse Aeration Wiring	32
Hydraulic Motor	33,36
Hydraulic Pump	37,41
Slide Gate Assembly	42
Electrical Control Panel 440 volt 3 phase with Remote Control	43
Electrical Control Panel 240 volt 3 phase with Remote Control	44
Electrical Control Panel 240 volt Single phase with Remote Control	45
Optional Remote Control for Gas & Diesel Engines	46
Load Cell J Box Wiring Diagram	47
Cardinal Scale Manual	
Honda Engine Manual	

24'-9 1/16"

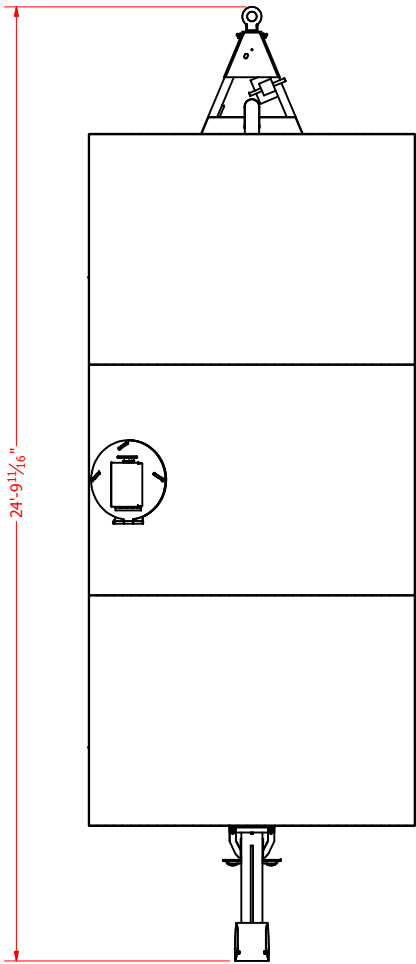

12'-2 13/16"

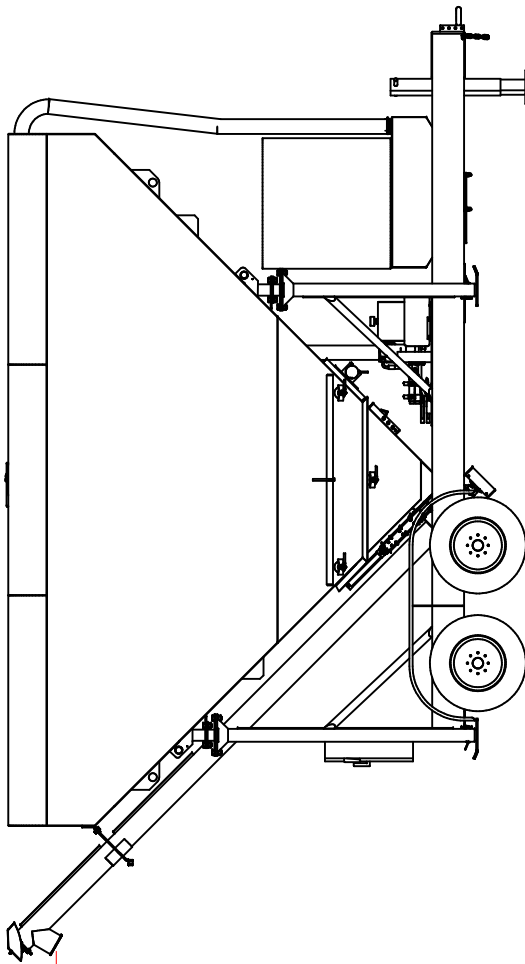

8'-6"

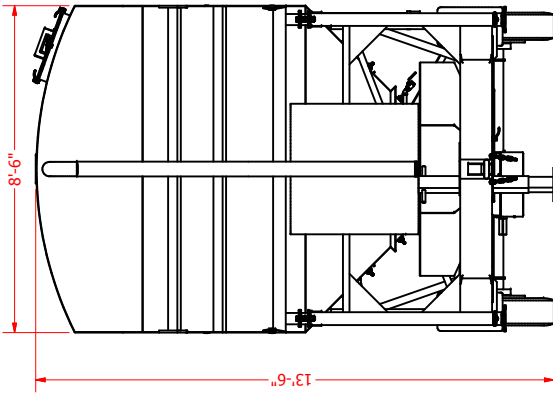

13'-6"

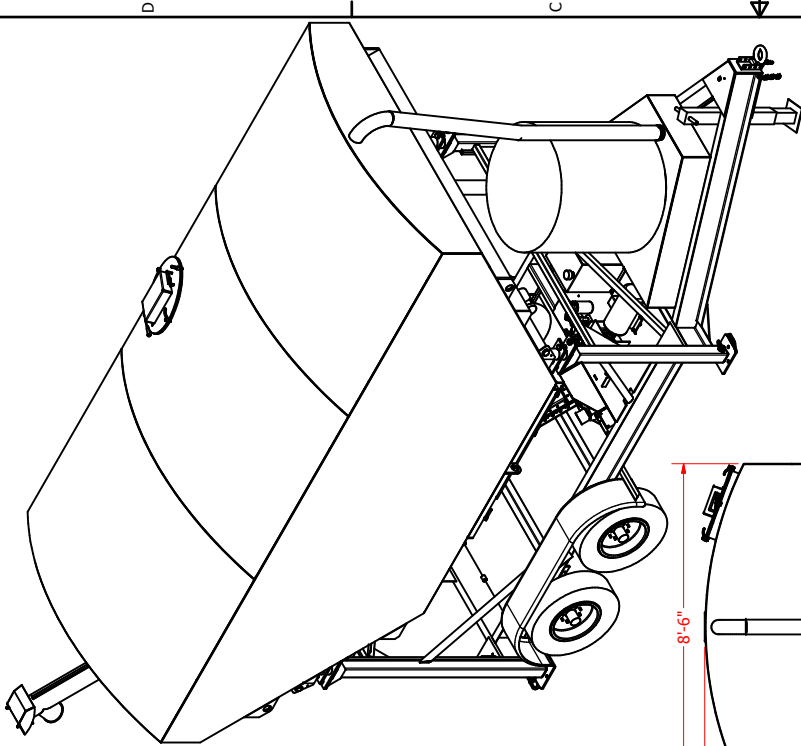

PROJECTION
 REMOVE ALL BURRS
 UNLESS OTHERWISE SPECIFIED
 DIMENSIONS ARE IN INCHES
 TOLERANCES ARE:
 .XX ± .01
 .XXX ± .005
 FRACTION ± 1/32
 ANGLES ± 1'
 DRILLED HOLE ± 1/64

DRAWN
T. Henry

CHECKED
QA

MFG
MFG

MATERIAL
8435.4 lbmass

MASS
8435.4 lbmass

3/13/2019

2011 Harnish Blvd.
Billings MT 59101

IDEAL MFG., INC.

SI-LOW 206 H2

SCALE 1 / 30

DWG NO SI-LOW 206 H2

REV

Si-Low 206 H2

440 / 460 VOLT THREE PHASE

COMBINATION STARTER
 513-BJB-A2G-1-40-6P
 5 HP 3 PHASE 440 V
 NEMA SIZE 1
 15 AMP CIRCUIT BREAKER

500 F-BOD 930 STARTER
 592-EEEC OVERLOAD RELAY
 1497-B-BASX-3N TRANSFORMER
 PRIMARY FUSE 1 AMP/KLDR
 SECONDARY FUSE .75 AMP/FLM
 ENCLOSURE SIZE

10"W X 26 3/8"H X 8 7/32" DEEP
 TRANSFORMER
 .500 KVA #PED280

DOUBLE FUSE HOLDER
 F1 FUSE 3A 600V
 #PED931
 FUSE #PED932

SINGLE FUSE HOLDER
 #PED933
 F2 FUSE 6.25A 250V
 FUSE #PED934

SWITCH FOR/OFF/REV
 #PDD973

SWITCH OPEN/CLOSE
 #PDD974

SWITCH OFF/ON
 #PDD765

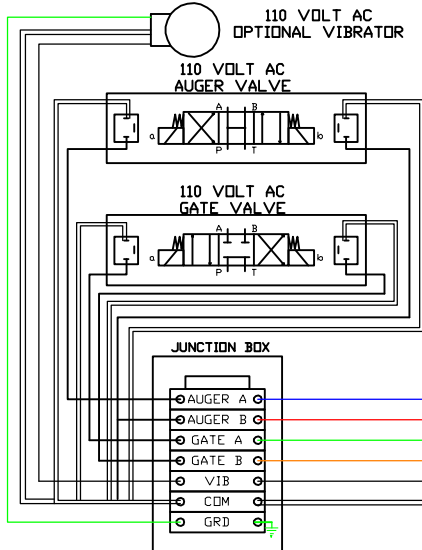
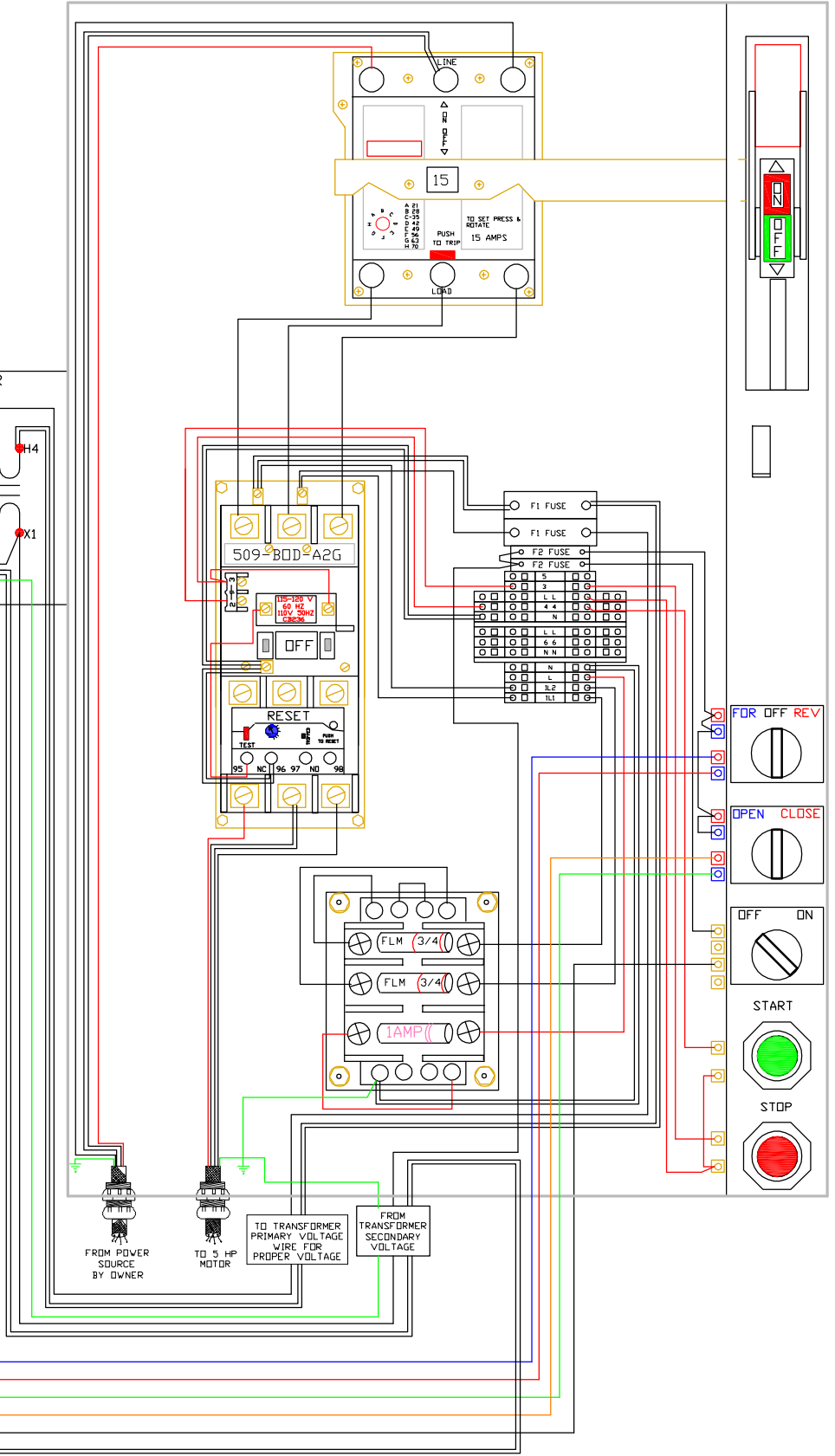
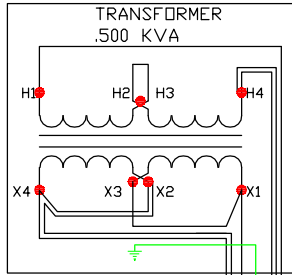

- JUNCTION BOX # PDD956
- END ANCHOR # PED620
- TERM BLOCK GREEN/YELLOW # PED621
- TERM BLOCK BLACK # PED622
- TERM BLOCK RED # PDD623
- TERM BLOCK GREY # PED624
- TERM BLOCK BROWN # PED644
- TERM BLOCK YELLOW # PED645
- TERM BLOCK ORANGE # PED646
- DIN TRACK 4 3/4" # PED637

LEGEND

- WHITE
- RED
- BLACK
- GREEN

REVISIONS		
NO	DATE	DESCRIPTION

IDEAL MANUFACTURING INC
 201 HARRISON BLVD. BILLINGS MT 59103
 PHONE: (406)656-4360 FAX: (406)656-4363

SI-LOW 206 H2
 ELECTRICAL CONTROL PANEL

440 / 460 VOLT 3 PHASE
 PRIMARY 110 V SECONDARY

3-14-2019

208 / 240 VOLT THREE PHASE

COMBINATION STARTER
513-BJA-A2G-1-6P-40
5 HP 3 PHASE 240 V
NEMA SIZE 1
30 AMP CIRCUIT BREAKER

500F-BOD930 STARTER
592-EEEC OVERLOAD RELAY
1497--B-BASX-3N 80 VA TRANSFORMER
PRIMARY FUSE 1 AMP/KLDR
SECONDARY FUSE .75 AMP/FLM
ENCLOSURE SIZE
10"W X 26 3/8"H X 8 7/32" DEEP

10"W X 26 3/8"H X 8 7/32" DEEP
TRANSFORMER
.500 KVA #PE0280

DOUBLE FUSE HOLDER
F1 FUSE 3A 600V
#PE0931
FUSE #PE0932

SINGLE FUSE HOLDER
#PE0933
F2 FUSE 6.25A 250V
FUSE #PE0934

SWITCH FOR/OFF/REV
#P00973

SWITCH OPEN/CLOSE
#P00974

SWITCH OFF/ON
#P00765

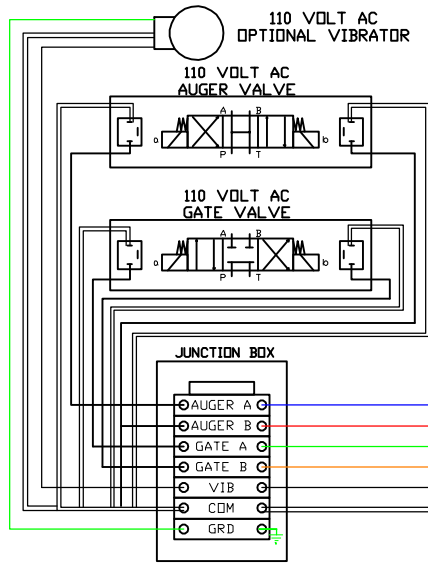
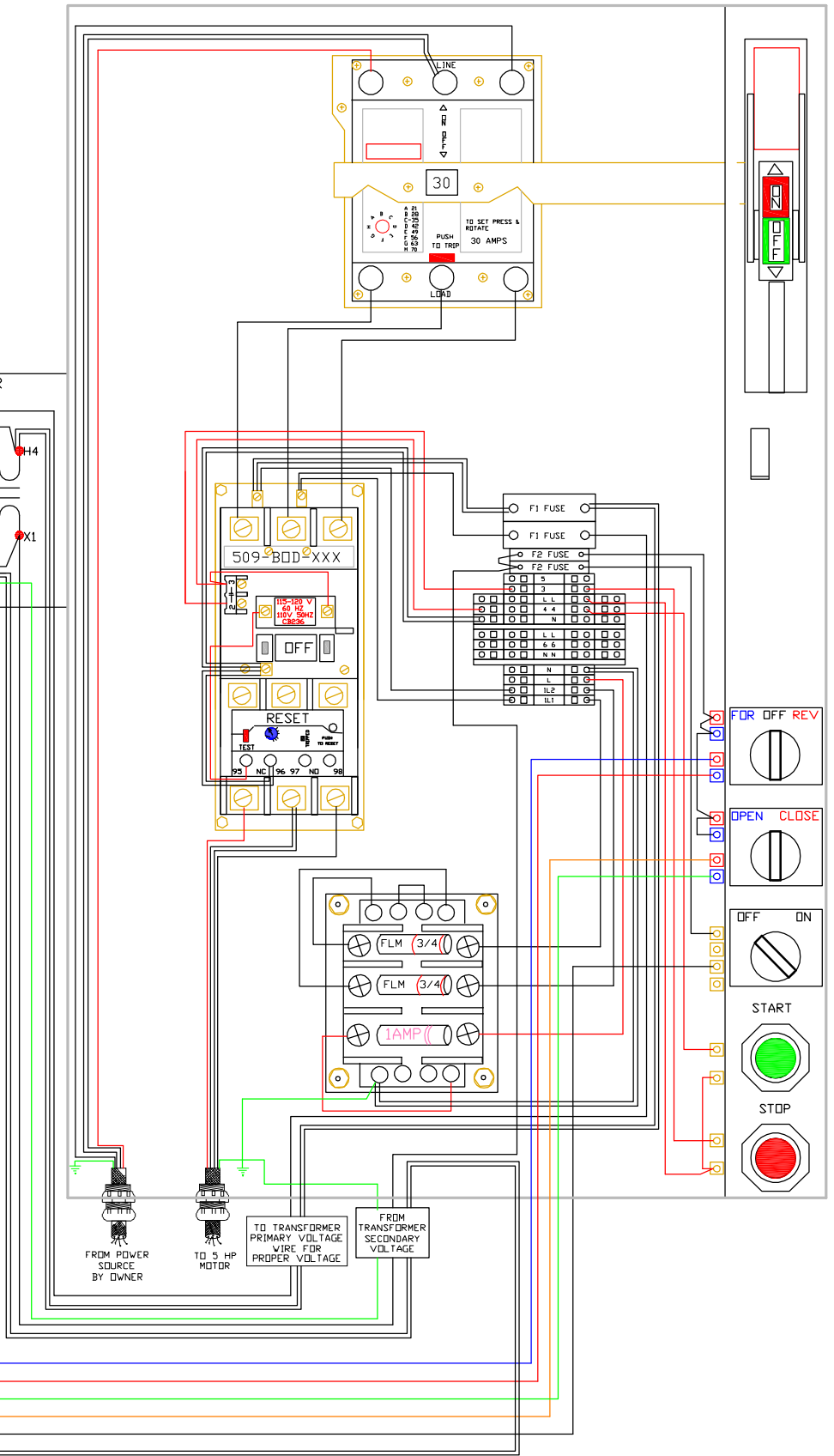
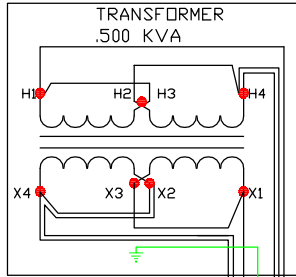

JUNCTION_BOX # P00956
END ANCHOR # PE0620
TERM BLOCK GREEN/YELLOW # PE0621
TERM BLOCK BLACK # PE0622
TERM BLOCK RED # PE0623

TERM BLOCK GREY # PE0624
TERM BLOCK BROWN # PE0644
TERM BLOCK YELLOW # PE0645
TERM BLOCK ORANGE # PE0646
DIN TRACK 4 3/4" # PE0637

LEGEND

- WHITE
- RED
- BLACK
- GREEN

REVISIONS			IDEAL MANUFACTURING INC.	
NO	DATE	DESCRIPTION	2011 HARNISH BLVD, BILLINGS MT, 59101	
			PHONE: (406)656-4300 FAX: (406)656-4363	
			Si-Low 206 H2	
			ELECTRICAL CONTROL PANEL	
			240 / 208 VOLT 3 PHASE	
			PRIMARY 110 V SECONDARY	
			3-14-2019	

208 / 240 VOLT SINGLE PHASE

COMBINATION STARTER
513-CJA-XXX-1-6P-42
5 HP SINGLE PHASE 240 V
NEMA SIZE 1
50 AMP CIRCUIT BREAKER

509 F-BDD 930 STARTER
5925-EEUD 18-90 AMP OVERLOAD RELAY
1497-N2PK 80 VA TRANSFORMER
PRIMARY FUSE 1 AMP/KLDR
SECONDARY FUSE .75 AMP/FLM
ENCLOSURE SIZE
10"W X 26 3/8"H X 8 7/32" DEEP

TRANSFORMER
.500 KVA #PE0280
DOUBLE FUSE HOLDER
F1 FUSE 3A 600V

FUSE #PE0932

SINGLE FUSE HOLDER

F2 FUSE 6.25A 250V
FUSE #PE0934

SWITCH FOR/OFF/REV

SWITCH OPEN/CLOSE

SWITCH OFF/DN

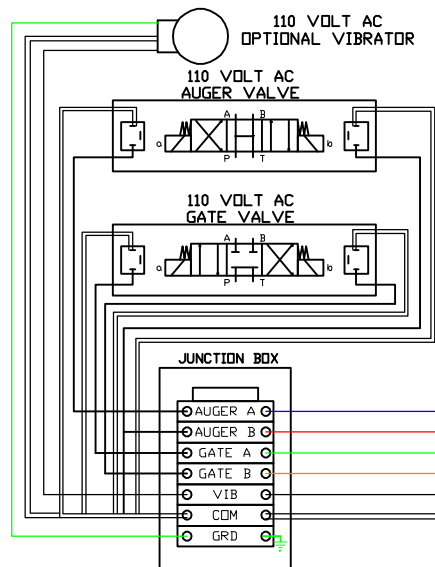
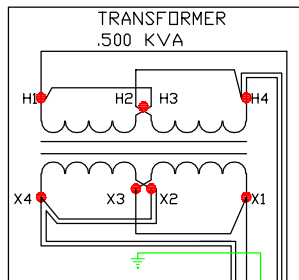

- JUNCTION BOX # P00956
- END ANCHOR # PED620
- TERM BLOCK GREEN/YELLOW # PED621
- TERM BLOCK BLACK # PED622
- TERM BLOCK RED # P00623
- TERM BLOCK GREY # PED624
- TERM BLOCK BROWN # PED644
- TERM BLOCK YELLOW # PED645
- TERM BLOCK ORANGE # PED646
- DIN TRACK 4 3/4" # PED637

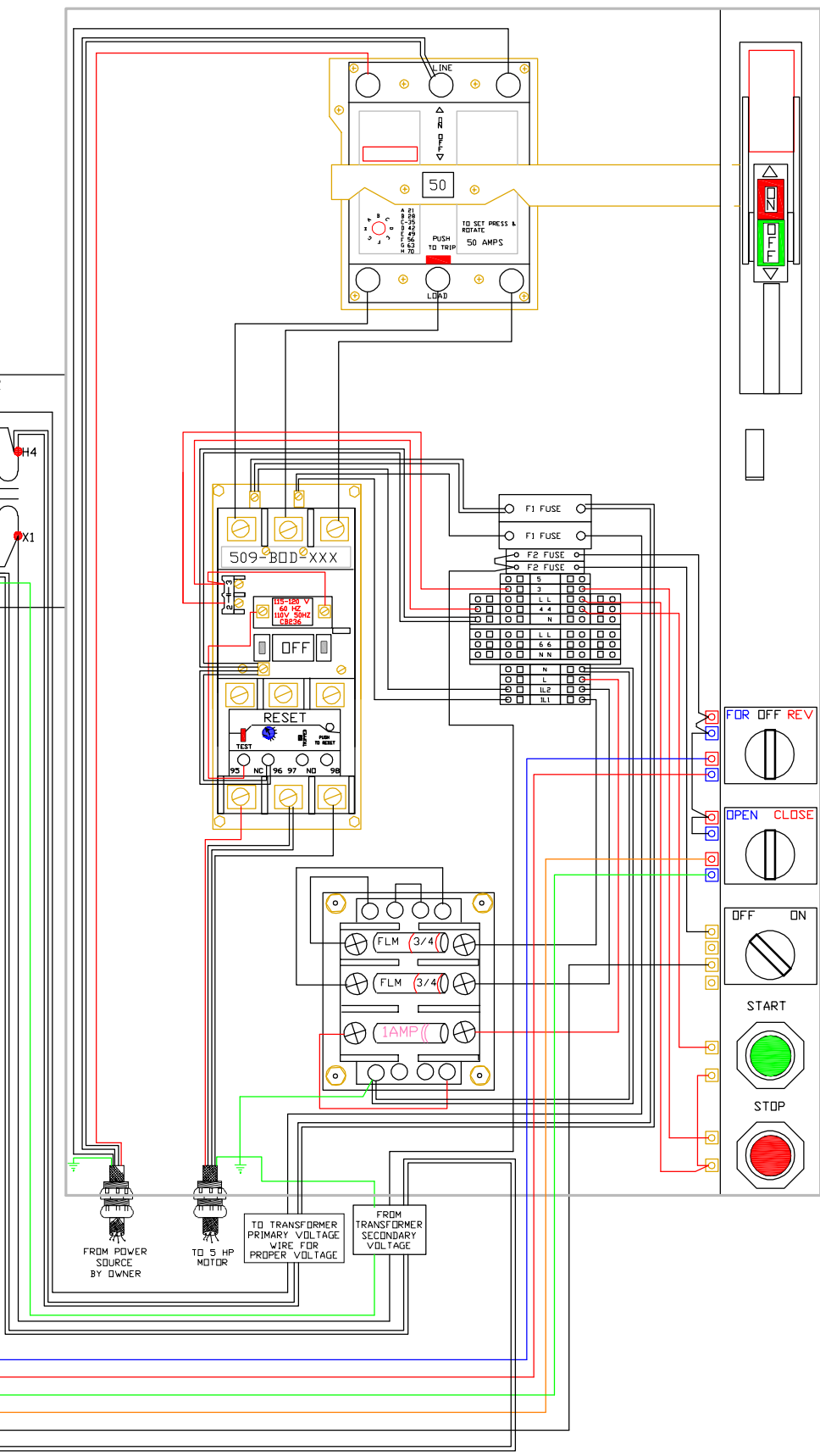

LEGEND	
—	WHITE
—	RED
—	BLACK
—	GREEN

REVISIONS		
NO	DATE	DESCRIPTION

IDEAL MANUFACTURING INC.
2011 HARNISH BLVD, BILLINGS MT, 59001
PHONE: (406)656-4360 FAX: (406)656-4363

Si-Low 206 H2
ELECTRICAL CONTROL PANEL

240 VOLT SINGLE PHASE
PRIMARY 110 V SECONDARY

3-14-2019

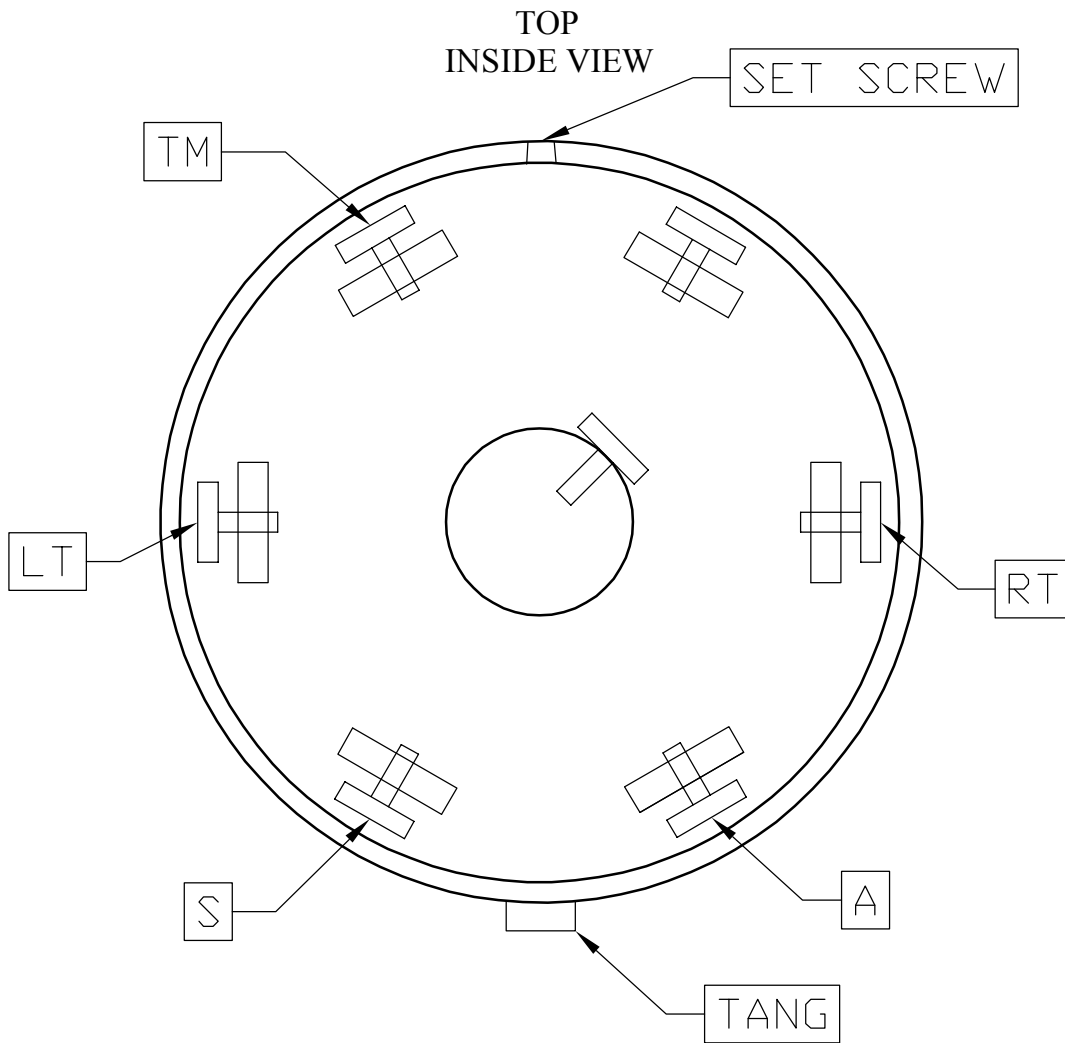

SEVEN POLE PLUG CONNECTOR

	DESCRIPTION	
TM	Tail & Clearance Lights	BROWN
S	Brake Ground	WHITE
RT	Right Signal	GREEN
LT	Left Signal	YELLOW
GD	Ground for Lights	WHITE
A	Hot Wire for Brake	BLACK

Si-Low-206 H2
ELECTRICAL CONNECTOR FOR TOWING

DATE
3-14-20194

Si-Low-206 H2

MAIN COMPONENT LIST

REF#	DESCRIPTION
1	Auger to Silo attachment components
2	Hydraulic Components and Electric Motor
3	Electrical Box
4	Aeration System
5	Fill Pipe
6	Bag Type Dust Collector and Clean Out Hopper
7	Tongue Jack
8	Adjustable Leg Assembly
9	Auger Drive Assembly
10	Man Hole
11	Upper Bearing Assembly
12	Vent Hose
13	Red Side Marker
14	Red Brake Light
15	Amber Side Marker
16	Tire and Axle Assembly
17	Cement Silo 200 Barrel capacity (30 tons)
18	Auger
19	Main Frame
20	Lifting Eyes

Si-Low-206-H2

PREPARING SILO FOR TRANSPORT

1. Most important is to be positive that all cement has been removed from silo, auger and bag-house.
2. Using a rubber mallet, hit the sidewalls of hopper section of silo; listening for a hollow sound. Clean out remaining cement. A bag of floor dry will aid in cleaning out the auger by opening the manhole on top of the silo, pour the floor dry inside of the cement silo. Turn auger on, open discharge gate. Run auger until the floor dry no longer comes out of discharge end of auger. Turn auger off and close discharge gate.
3. Disconnect air supply.
4. Disconnect electrical supply. **CAUTION! Only a qualified person should do this.**
5. Using top-wind tongue jack, raise front of cement silo until all weight is off both front legs.
6. Remove keepers from both front leg pins, slowly remove leg pins. **CAUTION! Inner leg will fall to ground. STAY CLEAR WHEN REMOVING LEG PINS.**
7. Using handle on leg pad, raise leg until pin can be installed in first hole. Install leg pin through hole, install keeper. Repeat on second leg at front of cement silo.
8. Using tongue jack, lower front of cement silo until all weight is on both rear legs.
9. Remove keepers from both leg pins; slowly remove leg pins. **CAUTION! Inner leg will fall to ground. STAY CLEAR WHEN REMOVING LEG PINS!**
10. Using handle on leg pad, raise leg until leg pin can be installed in first hole. Install leg pin through hole and install keeper. Repeat on second leg at rear of cement silo.
11. Using tongue jack, raise front of cement silo until tow vehicle can back under pintle hitch.
12. Back tow vehicle under pintle hitch, using top-wind tongue jack, lower front of cement silo onto tow vehicle hitch, secure latch. Hook safety chains and break-away cable to tow vehicle. Plug in lights, check lights for proper operation.
13. Raise tongue jack to full up position and put foot- pad in retaining hole. See drawing (Adjustable Legs) on page 27. .

Si-Low-206 H2

SET UP PROCEDURE

1. Select a level site with solid footing for setting up and operating cement silo.
2. Block tires, to keep cement silo from moving, before unhooking tow vehicle.
3. Unhook tow vehicle, move vehicle away from cement silo.
4. Remove keepers from both leg pins at rear of cement silo. Slowly remove leg pins. CAUTION! Inner leg will fall to ground; STAY CLEAR WHEN REMOVING LEG PINS! See page 27.
5. Using tongue jack, lower front end of silo until leg pins can be installed in second hole in rear legs.
6. Install leg pins through holes in both rear legs; install keepers.
7. Remove keepers from both leg pins, at front of silo. Slowly remove leg pins CAUTION! Inner leg will fall to ground. STAY CLEAR WHEN REMOVING LEG PINS!
8. Using tongue jack, raise front of cement silo until leg pins can be installed in second hole in front legs
9. Install leg pins through holes in both front legs; install keepers.
10. Using tongue jack, lower front of cement silo until all weight is off jack.
11. Check cement silo for level and stability. Correct as needed.
12. Connect electric power to disconnect box at rear of cement silo, using qualified person. Check for proper rotation of hydraulic pump. Correct as needed.
13. Connect air supply to valve. Silo fluidizer aerators require 10.2 CFM @ 90 PSI with a 60 gallon tank. See drawing on page 30.

SAFETY RULES

Warning: Maximum Hydraulic PSI Setting is 1800, do not exceed this pressure.

Follow instructions. Don't take chances. If you don't know, ask. When setting up lowering or putting equipment into traveling position, follow all instructions in operator's manual.

Correct or report unsafe conditions. If you are not sure of how to correct a hazard, report it and get help.

Help keep everything clean and orderly. Trips or falls can cause serious injuries.

Use the right tools and equipment for the job. Use them safely. Replace all machine guards after repairs.

Report all injuries and get first aid or medical treatment promptly.

Use, adjust and repair equipment only when authorized.

Use prescribed protective equipment. Keep it in good condition. Wear your hard hat, safety climbing devices or belt. Wear safe clothing to protect you from material being handled, cold or hot. Wear dust mask when conditions require them. Gloves, safety glasses or eye protection, and ear plugs for noise.

Don't horseplay; avoid distracting others.

When lifting, bend your knees and get help for heavy loads.

Don't repair or adjust equipment while in motion. Shut off power at source, gasoline engines or electric motors.

Gasoline, L.P. gases fumes are highly explosive.

NOTES:

Si-Low-206 H2
OPERATING PROCEDURE
Reference Drawing # SL 206-H2-201A

A. CHARGING SILO

1. Close silo discharge gate, (REF# 1)
2. Air pump cement through filler pipe, (REF# 5) do not exceed 8 PSI while filling silo.
3. You must shake upper section of bag-house to clean filter bags each time after filling silo. (REF #6) Weekly inspection of filter bags is recommended.
4. You must after filling silo each time open cleanout gate, at bottom of bag-house hopper, remove over flow cement from hopper; close gate. (REF #2)
5. Bimonthly inspection of over pressure valves is recommended. (REF #7)

B. AUGER OPERATION

1. Check oil level in hydraulic tank. Oil should be within 5" of top. Use all season grade 32 hydraulic oil when adding oil. Raise disconnect handle on electrical panel to ON position. (REF #3).
2. Start the electric motor, push start button, or gas / diesel engine to let the hydraulic pump warm up.
3. Open discharge gate by holding the gate switch to open position. When gate is opened completely release switch. (REF#1)
4. Turn air supply on. (Supplied by customer)
5. Open ball valve on aerator system for one minute. Close ball valve. If optional pulse system is purchased turn air valve control to ON position. (REF# 3). (Optional)
6. Turn auger control switch to forward, (REF # 3). Auger will start. Turn vibrator on when needed. Optional aerators will pulse on for three seconds, off for seven seconds, until stop button is pushed.

NOTE: If slower delivery of cement is needed; close discharge gate to get desired amount.

7. Fill unit with cement.
8. When unit is filled turn auger control switch to off, and turn vibrator off. (REF #3)
9. Close discharge gate, and turn electric motor off. (REF # 1).
10. Lower disconnect handle on electrical panel to OFF position. (REF #3).

NOTE: The auger should be emptied on last load of the shift.
Hydraulic pump system maybe left running between unloading as long as excess heat does not build up.

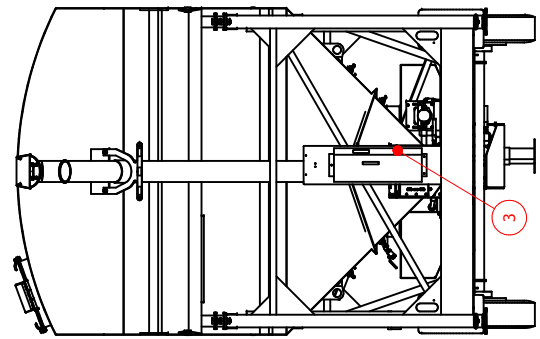
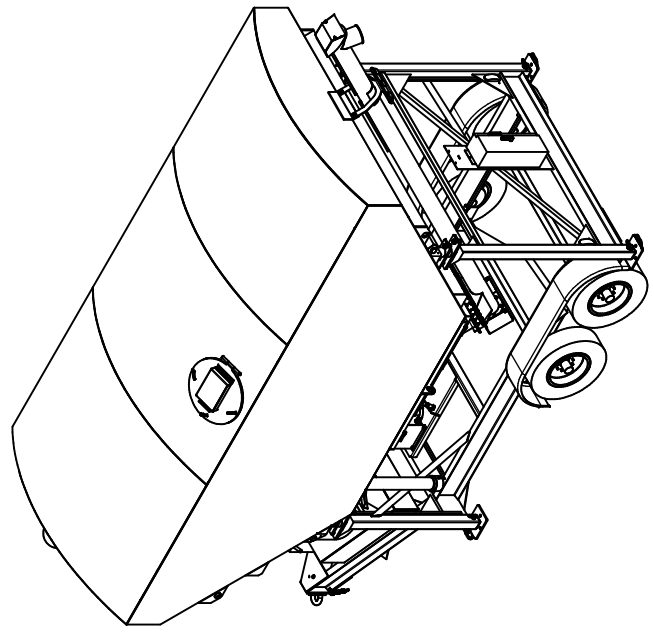
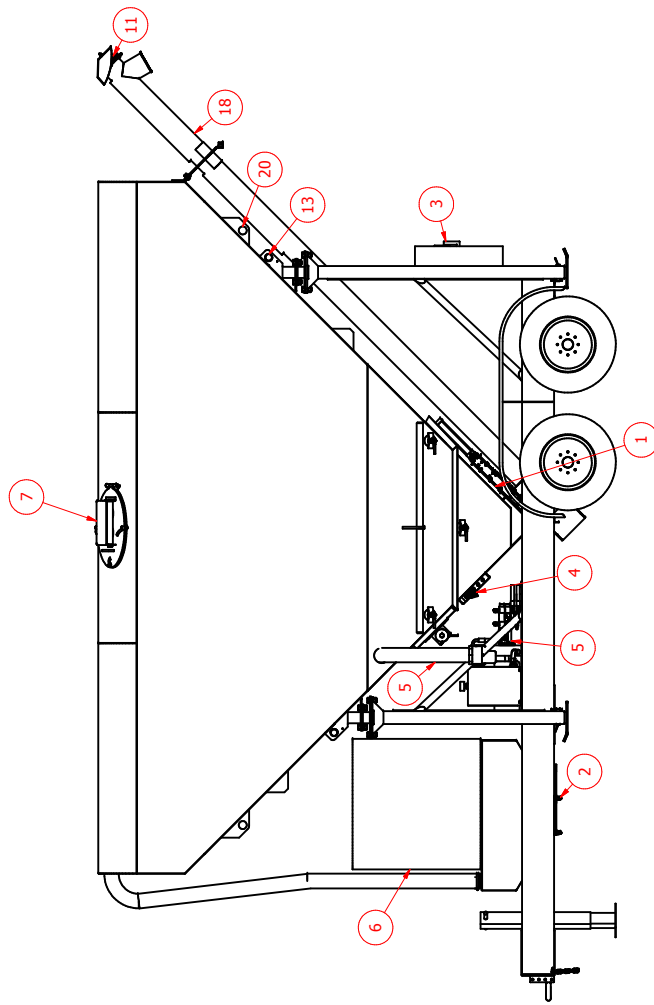
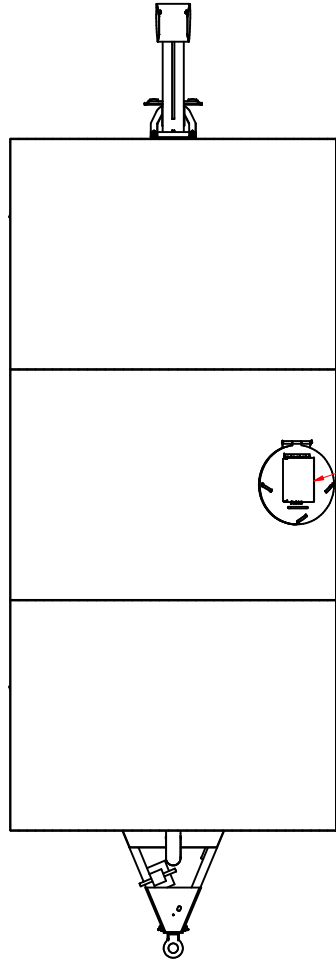

Si-Low 206 H2 OPERATING PROCEDURE

 PROJECTION REMOVE ALL BURRS UNLESS OTHERWISE SPECIFIED DIMENSIONS ARE IN INCHES TOLERANCES ARE: .XX ± .01 .XXX ± .005 FRACTION ± 1/32 ANGLES ± 1° DRILLED HOLE ± 1/64	DRAWN T Henry CHECKED QA MFG MATERIAL MASS 8435.4 lbmass	3/14/2019 2011 Harnish Blvd. Billings MT 59101	Ideal Mfg., Inc. SI-LOW 206 H2 SL 206-H2-201A
SCALE 1 / 30	SIZE C	DWG NO SL 206-H2-201A	REV

Si-Low 206 H2
HYDRAULIC SYSTEM ELECTRIC MOTOR
Reference Drawing # SL 206-H2-202

REF NO.	PART NO.	DESCRIPTION	REQ'D
1	N/A	Key 1/4 X 1 1/4	1
2	N/A	Hex Bolt 3/8-16 X 1 1/4	10
3	N/A	Lock Washer 3/8	14
4	N/A	Hex Nut 3/8-16	14
5	N/A	Flat Washer 3/8	4
6	N/A	Hex Bolt 5/16-18 X 7/8	6
7	N/A	Lock Washer 5/16	6
8	N/A	Hex Nut 5/16-18	6
9	N/A	Hex Bolt 3/8-16 X 1	4
10	N/A	Key 5/32 x 3/4	1
11	N/A	Socket Head Cap Screw 10-24 X 3 1/2	4
12	N/A	Hex Bolt 5/16-18 X 1/2	4
13	N/A	Machine Screw 6-32 X 1 1/2	4
14	N/A	O Ring	12
15	N/A	DO3 Mount Bracket	2
16	N/A	Socket Head Cap Screw 10-24 X 2	4
POO434	POO434	1/2 NPT Plug	1
POO635	POO635	5 HP Motor	1
POO862	POO862	16-12 Straight JIC /ORB	1
POO864	POO864	Breather	1
POO866	POO866	Filter Housing	1
POO866A	POO866A	Filter	1
POO870	POO870	16-16 Straight JIC / NPT	1
POO875	POO875	Coupler Electric Motor	1
POO876	POO876	Coupler Hydraulic Pump	1
POO877	POO877	Coupler Insert	1
POO878	POO878	Hydraulic Pump	1
POO961	POO961	10-12 Straight JIC / NPT	1
POO963	POO963	10-10 Straight JIC / ORB	3
POO964	POO964	10-08 Straight JIC / ORB	2
POO965	POO965	04-08 Straight JIC / ORB	2
POO966	POO966	DO3 Manifold	1
POO967	POO967	Sandwich Body for auger	1
POO968	POO968	Relief Cartridge (set at 1800 PSI Max)	1
POO969	POO969	Relief Cartridge (set at 1000 PSI Max)	1
POO970	POO970	Valve 110 volt ac coil (motor)	1
POO970A	POO970A	Valve 12 volt dc coil (motor)	1
POO971	POO971	Valve 110 volt coil (gate)	1
POO971A	POO971A	Valve 12 dc coil (gate)	1
POO972	POO972	DIN Connector	4
POO975	POO975	1" Hydraulic Hose Suction 30 1/2" Long	1
POO976	POO976	5/8" Hydraulic Hose Pressure 18 1/2" Long	1
POO977	POO977	5/8" Hydraulic Hose Return 20 1/2" Long	1
POO978	POO978	5/8" Hydraulic Hose Work 43" Long	2
POO979	POO979	1/4" Hydraulic Hose Gate 67 1/2" Long	1
POO979A	POO979A	1/4" Hydraulic Hose Gate 78 1/2" Long	1
SSC101	SSC101	Hydraulic Tank	1
SSC107	SSC107	Pump Guard	1
SSC108	SSC108	Hydraulic Pump Mount	1

SI-LOW 206 H2 HYDRAULIC SYSTEM ELECTRIC MOTOR

Hydraulic oil level should be about 4" to 5" below top of tank. When adding hydraulic oil use all season grade 32 hydraulic oil.

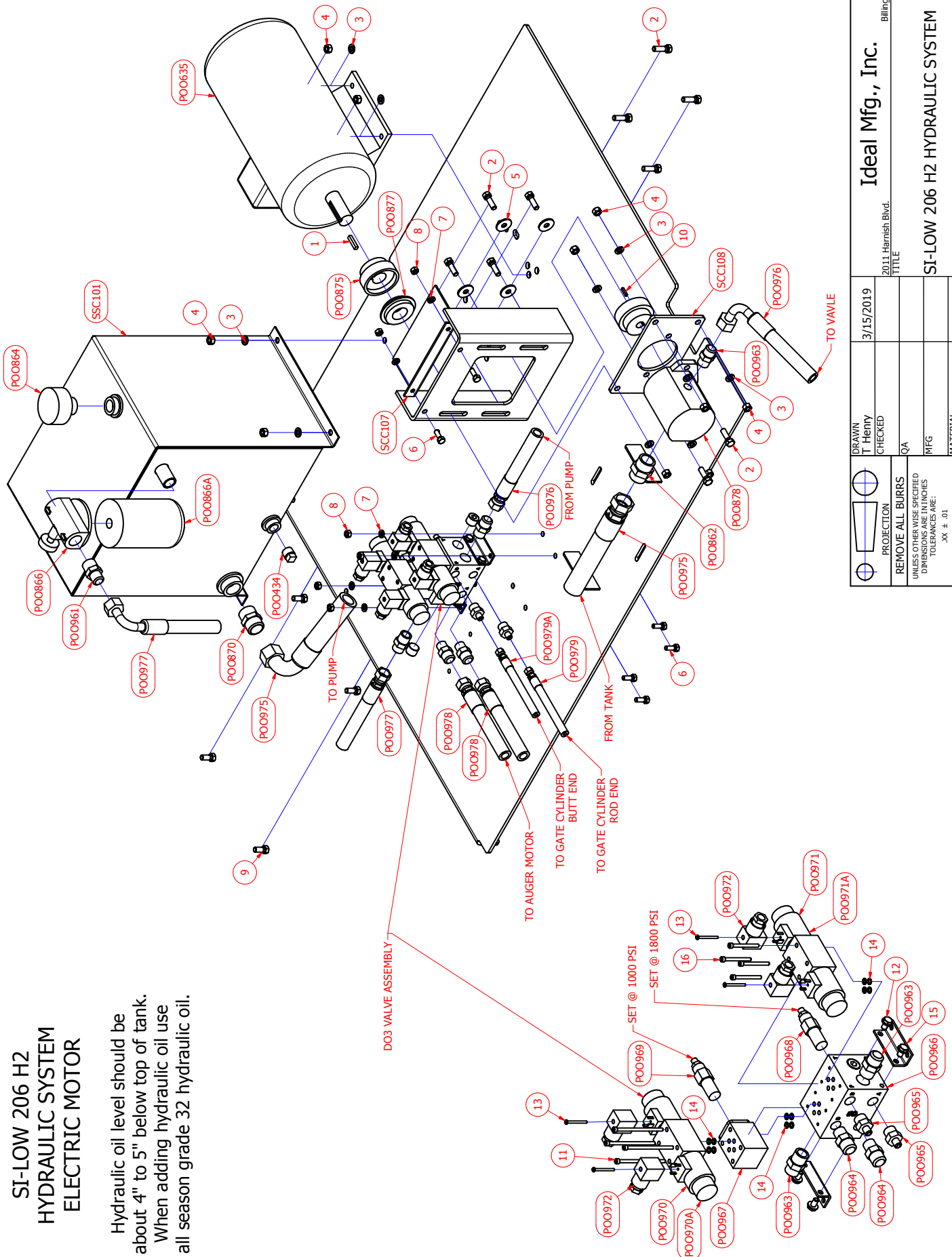

DRAWN T Henry		3/15/2019	Ideal Mfg., Inc.	
CHECKED QA			2011 Harnish Blvd. Billings MT 59101	
MFG			TITLE	
MATERIAL			SI-LOW 206 H2 HYDRAULIC SYSTEM	
MASS N/A			DWG NO SL206-H2-202	
SIZE C			SCALE 0.2 : 1	
REV			SHEET 1 OF 1	

PROJECTION	REMOVE ALL BURRS UNLESS OTHERWISE SPECIFIED DIMENSIONS ARE IN INCHES TOLERANCES ARE: .XX ± .01 .XXX ± .005 FRACTION ± 1/32 ANGLES ± 1' DRILLED HOLE ± 1/64
------------	--

Si-Low 206 H2
HYDRAULIC SYSTEM
GAS AND DIESEL ENGINE
Reference drawing # SL206-H2-203

REF NO.	PART NO.	DESCRIPTION	REQ'D
1	N/A	Flat Washer 3/8	6
2	N/A	Hex Bolt 3/8-16 X 1 1/4	6
3	N/A	Lock Washer 3/8	14
4	N/A	Hex Nut 3/8-16	14
5	N/A	Hex Bolt 5/16-18 X 7/8	6
6	N/A	Lock Washer 5/16	6
7	N/A	Hex Nut 5/16-18	6
8	N/A	Key 5/32 X 3/4	1
9	N/A	Key 1/4 X 1 1/4	1
10	N/A	Hex Bolt 3/8-16 X 1 3/4	4
11	N/A	Hex Bolt 3/8-16 X 1	4
POO268	POO268	Battery Ground Strap	1
POO269	POO269	Battery Terminal	1
POO374	POO374	12 Volt Battery	1
POO374A	POO374A	Battery Box	1
POO434	POO434	1/2NPT Plug	1
POO502	POO502	Diesel Engine	1
POO507	POO507	Gas Engine	1
POO862A	POO862A	16-12 Straight JIC / ORB	1
POO864	POO864	Breather	1
POO866	POO866	Filter Housing	1
POO866A	POO866A	Filter	1
POO870	POO870	16-16 Straight JIC / NPT	1
POO875A	POO875A	Coupler Engine	1
POO876	POO876	Coupler Hydraulic Pump	1
POO877	POO877	Coupling Insert	1
POO878A	POO878A	Hydraulic Pump	1
POO961	POO961	10-12 Straight JIC / NPT	1
POO964	POO964	10-8 Straight JIC / ORB	1
POO975	POO975	1" Hydraulic Hose Suction 30 1/2" Long	1
POO976	POO976	5/8" Hydraulic Hose Pressure 18 1/2" Long	1
POO977	POO977	5/8" Hydraulic Hose Return 20 1/2" Long	1
POO978	POO978	5/8" Hydraulic Hose Auger Motor 43" Long	2
POO979	POO979	1/4" Hydraulic Hose Gate Cylinder 67 1/2" Long	1
POO979A	POO979A	1/4" Hydraulic Hose Gate Cylinder 78 1/2" Long	1
SSC101	SSC101	Hydraulic Tank	1
SSC107	SSC107	Pump Guard	1
SSC108	SSC108	Hydraulic Pump Mount	1

SI-LOW 206 H2 HYDRAULIC SYSTEM GAS AND DIESEL ENGINE

Hydraulic oil level should be about 4" to 5" below top of tank. When adding hydraulic oil use all season grade 32 hydraulic oil.

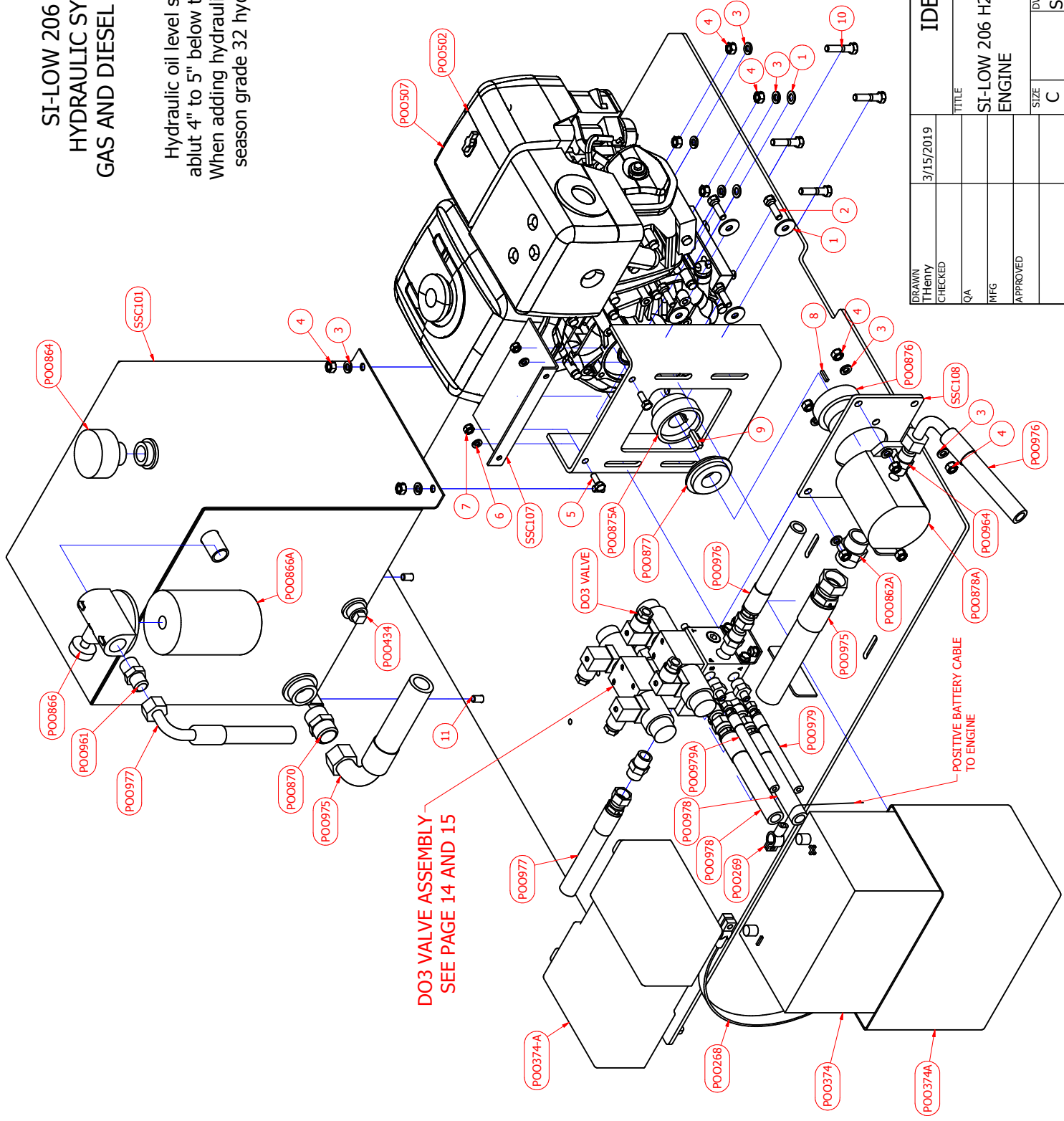

DO3 VALVE ASSEMBLY
SEE PAGE 14 AND 15

DRAWN THENNY		3/15/2019	IDEAL MFG., INC.	
CHECKED			TITLE	
QA			SI-LOW 206 H2 HYDRAULIC SYSTEM ENGINE	
MFG			SIZE	
APPROVED			C	
			DWG NO	
			SL 206-H2-203	
			SCALE	
			SHEET 1 OF 1	

Si-Low-206 H2

AUGER DRIVE ASSEMBLY WITH GUARD Reference Drawing # SL 206-H2-204

REF NO.	PART NO.	DESCRIPTION	REQ'D
1	N/A	Hex Bolt 3/8-16 X 1	6
2	N/A	Lock Washer 3/8	6
3	N/A	Hex Nut 3/8-16	6
4	N/A	Hex Bolt 1/4-20 X 3/4	4
5	N/A	Lock Washer 1/4	4
6	N/A	Hex Nut 1/4-20	4
7	N/A	Hex Nut 1/2-13	6
8	N/A	Flat Washer 1/2	36
9	N/A	Lock Washer 1/2	6
10	N/A	Hex Bolt 1/2-13 1 X 3/4	2
11	N/A	1/4 Key x 1 1/4	1
12	N/A	3/8 Key X 1 1/2	1
POO125	POO125	Felt Seal	1
POO127	POO127	# 60 Roller Chain	1
POO128	POO128	Sprocket Auger	1
POO129A	POO129A	Bearing	1
POO136	POO136	Master Link	1
POO963	POO963	10-10 JIC ORB Straight	2
POO984	POO984	Sprocket Motor	1
POO985	POO985	Hydraulic Motor	1
SLO336	SLO336	Felt Seal Plate	1
SLO402	SLO402	Auger Tube Assembly	1
SLO406	SLO406	Auger Flight Assembly	1
SLO407	SLO407	Sprocket Guard	1
SLO408	SLO408	Lower Bearing Mount	1

REF. NO.	PART NUMBER	QTY	DESCRIPTION
1	N/A	23	Hex Bolt 3/8-16 X 1
2	N/A	23	Lock Washers 3/8
3	N/A	19	Hex Nut 3/8-16
4	N/A	5	Hex Bolt 3/8-16 X 5/8
5	N/A	2	Nylock 5/16-18
6	N/A	2	Flat Head Cap Screw 5/16-18 X 1
7	N/A	1	Set Screw 1/4-20 x 3/8
8	N/A	12	Lock Washer 1/4
9	N/A	12	Hex Nut 1/4-20
10	N/A	1	Cylinder Rod End
SLO401	SLO401	1	AUGER TUBE ASSEMBLY
SLO402	SLO402	1	Stainless Steel Gate
SLO452	SLO452	1	Upper Guard
SLO461	SLO461	1	Hydraulic Cylinder
POO960	POO960	2	04-06 JIC ORB Straight
POO986	POO986	1	1/4 Hydraulic Hose 67 1/2" Long
POO979	POO979	1	1/4 Hydraulic Hose 78 1/2" Long
POO979A	POO979A	1	1/4 Hydraulic Hose 78 1/2" Long

SEE PAGE 42 FOR
SLIDE GATE ASSEMBLY
DRAWING # SL 206-H2-215

SI-LOW 206 H2 SLIDE GATE TO AUGER

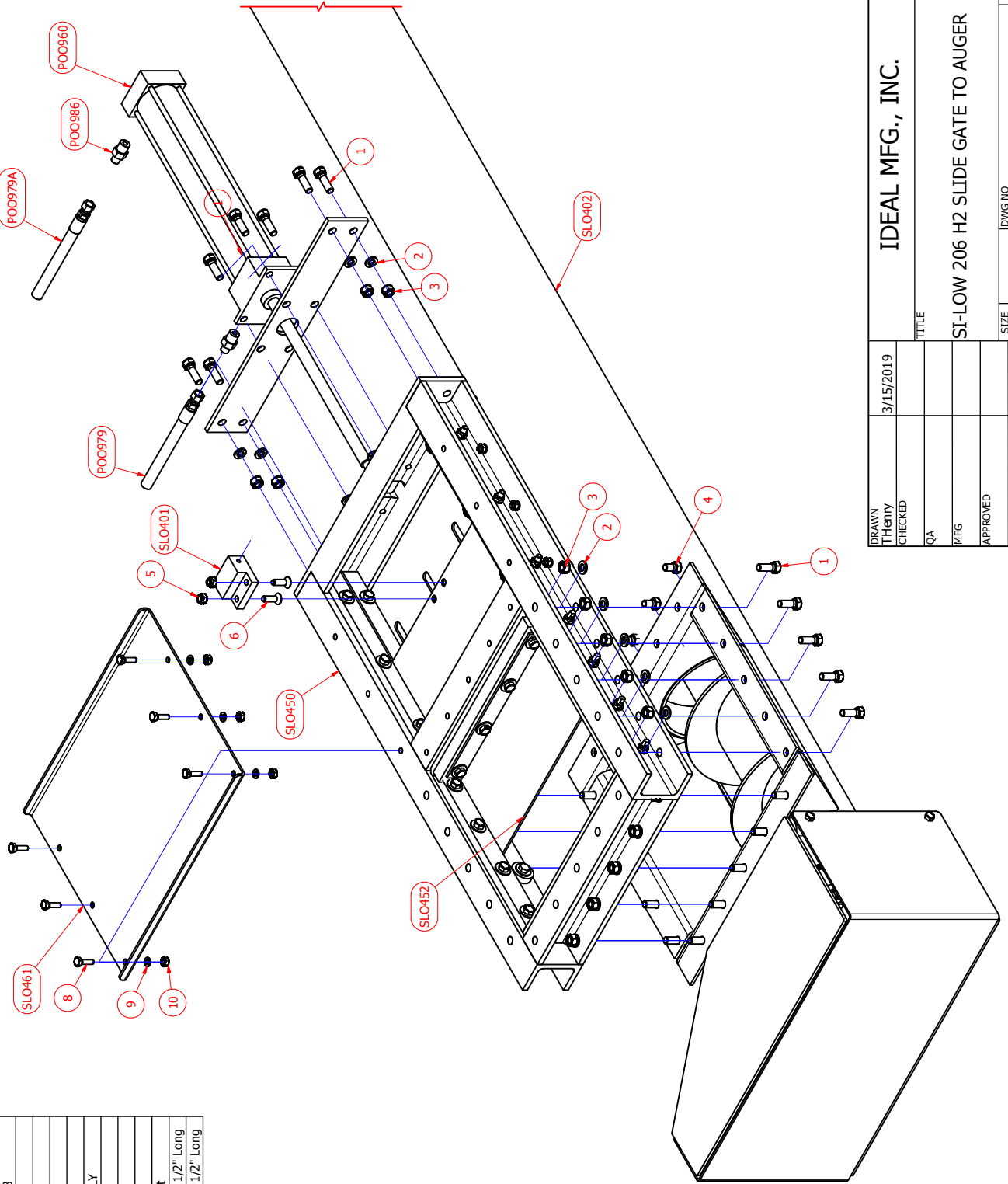

DRAWN T.Henry	3/15/2019	IDEAL MFG., INC.	
CHECKED		TITLE	
QA		SI-LOW 206 H2 SLIDE GATE TO AUGER	
MFG		SIZE	DWG NO
APPROVED		C	SL 206-H2-205
		SCALE	REV
			1
			SHEET 1 OF 1

SI-LOW 206 H2 AUGER UPPER BEARING ASSEMBLY

REF. NO.	PART NUMBER	QTY	DESCRIPTION
1	N/A	4	Hex Bolt 3/8-16 X 1
2	N/A	6	Lock Washer 3/8
3	N/A	6	Hex Nut 3/8-16
4	N/A	4	Lock Washer 1/2
5	N/A	4	Hex Nut 1/2-13
6	N/A	32	FLAT Washer 1/2
7	N/A	2	Hex Bolt 3/8-16 X 5
POO124	POO124	1	BEARING
POO125	POO125	1	FELT SEAL
SLO336	SLO336	1	FELT SEAL PLATE
SLO340	SLO340	1	UPPER AUGER FLANGE
SLO350	SLO350	1	RAIN CAP
SLO351	SLO351	2	SPACER
SLO402	SLO402	1	AUGER TUBE ASSEMBLY
SLO406	SLO406	1	AUGER FLIGHT ASSEMBLY

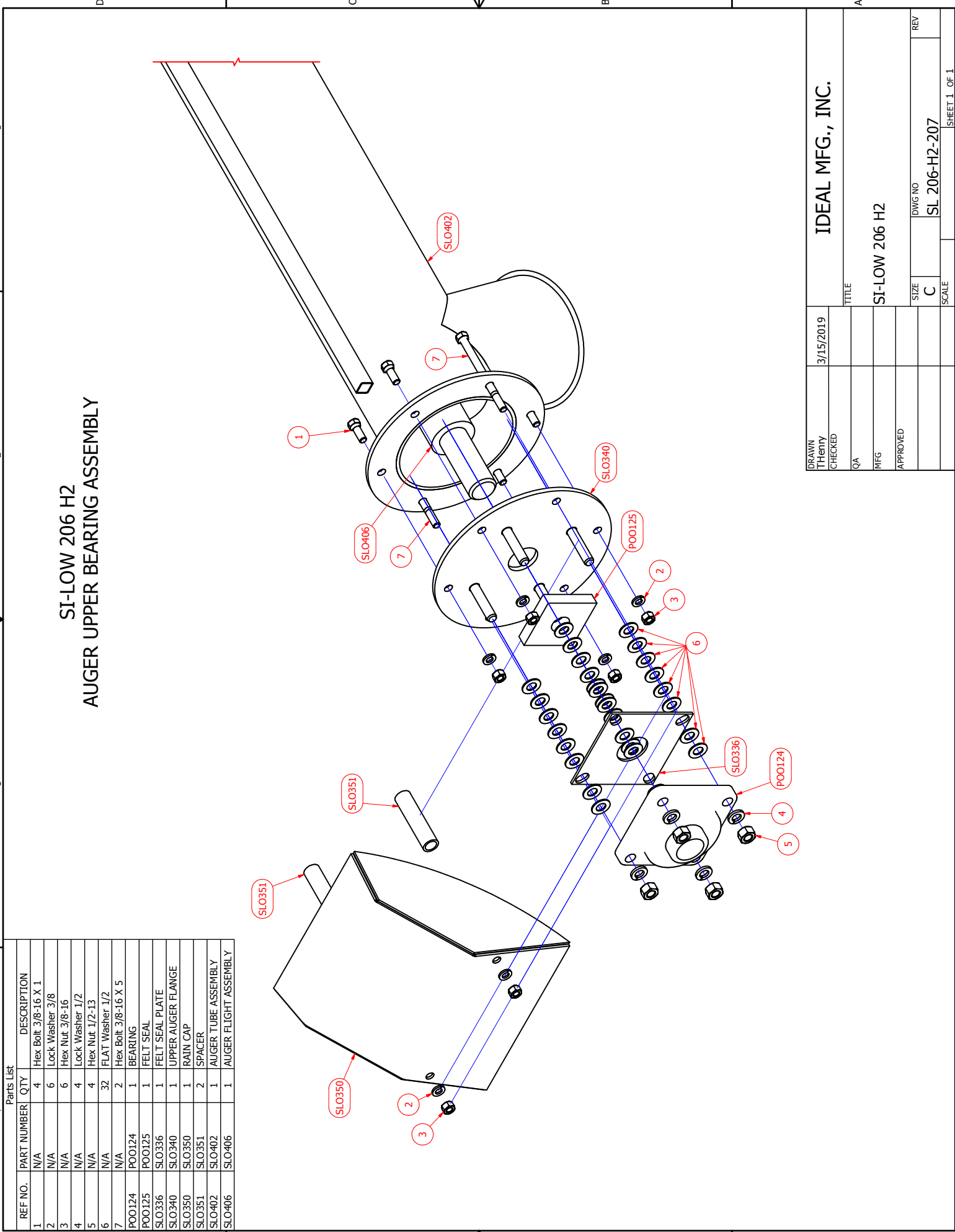

DRAWN	3/15/2019	IDEAL MFG., INC.
CHECKED		TITLE
QA		SI-LOW 206 H2
MFG		SIZE
APPROVED		C
		DWG NO
		SL 206-H2-207
		SCALE
		SHEET 1 OF 1

Si-Low 206 H2
 OPTIONAL CONTROL SYSTEM
 FOR ELECTRIC MOTOR
 see page 31 for 12 volt dc

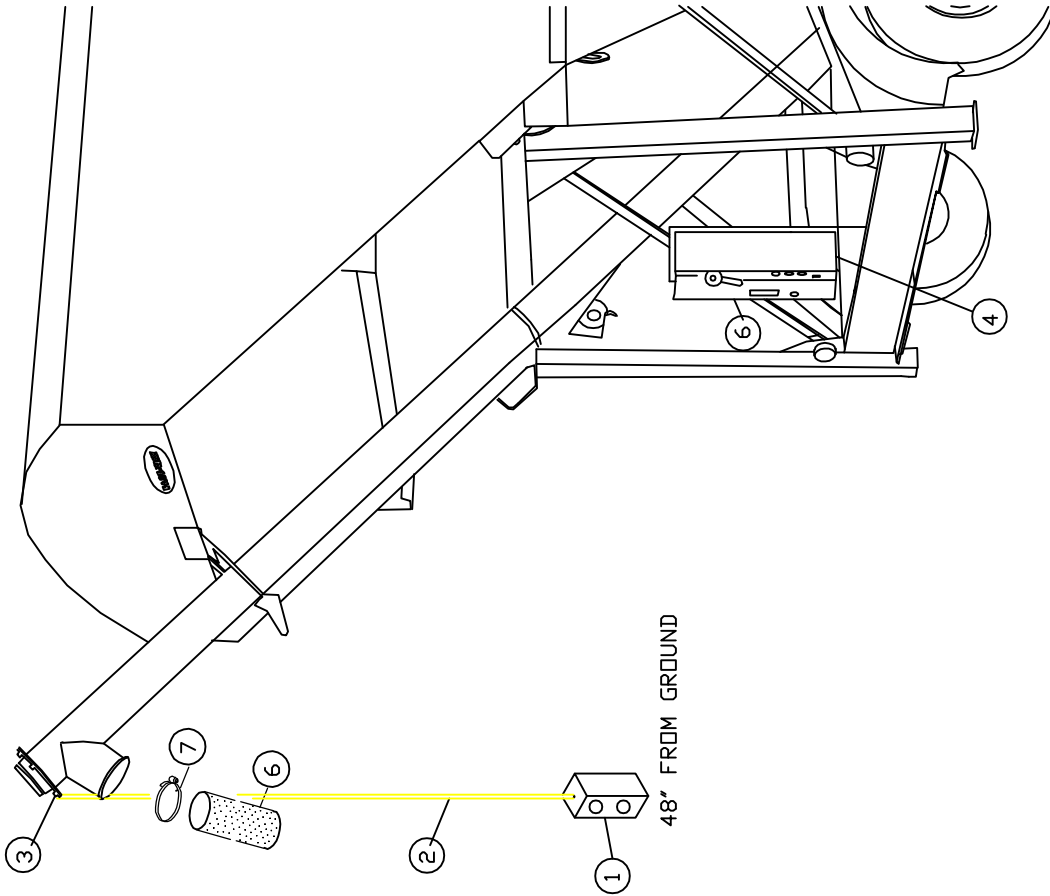

REF NO.	PART NO.	DESCRIPTION	REQ NO
1	POO772	Control Station	1
2	N/A	16/4 Electrical Wire 25'	1
3	N/A	DG-4 Clamp	2
4	PEO246	3- Cord Connector	1
5	POO908	Electrical Box 220 three phase	1
5	POO907	Electrical Box 440 three phase	1
6	POO122	Discharge Boot	1
7	POO121	Hose Clamp	1

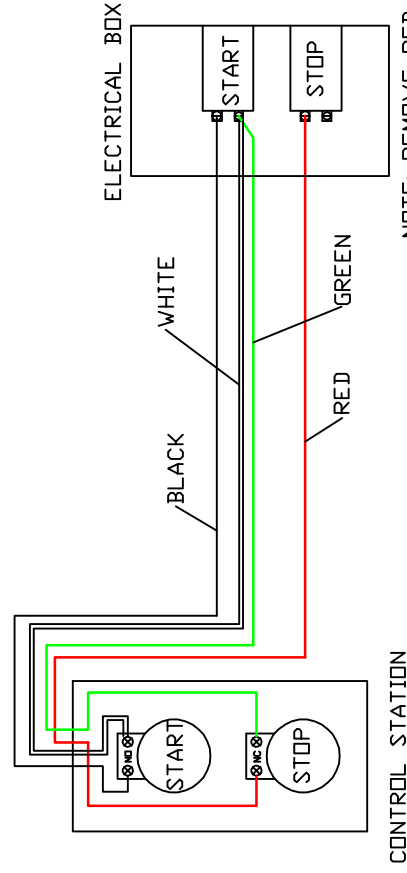

SILO BAGHOUSE

SUBJECT: Silo Baghouse (Air Filtering System)

PURPOSE: To prevent cement dust from entering the atmosphere during the filling process of the storage vessel.

DESCRIPTION: Filters:
Quantity - 18
Material - 10 oz polyester material -
25 cfm per square foot
Filter Surface - (each) 784 sq. in. = 5.44 sq. ft
Total square feet of filter material = 98 sq. ft.
Total cfm at 25 cfm per square foot = 2450 cfm

MAINTENANCE: Spring loaded upper bag mount that facilitates bag shaking both by wind action as well as manual action to result in filter bag cleaning. Clean out Hopper.

EFFICIENCY: 99.8%

Si-Low 206 H2
BAGHOUSE ASSEMBLY
Reference Drawing # SL 206-H2-208

REF NO.	PART NO.	DESCRIPTION	REQ'D
1	N/A	Hex Bolt 3/8-16 X 1 1/4	12
2	N/A	Lock Washer 3/8	14
3	N/A	Hex Nut 3/8-16	14
4	N/A	Hex Bolt 3/8-16 X 2 1/2	2
5	N/A	Flat Washer 3/8	10
6	N/A	Hex Bolt 3/8-16 X 3 1/2	4
7	N/A	Nylock 3/8-16	4
POO193	POO193	Clamp	20
POO196	POO196	Spring	4
POO365	POO365	Cover Weatherproof	1
POO364	POO364	Filter Bag	18
POO511	POO511	Gasket	1
POO693	POO693	Gasket	1
POO694	POO694	Flex Hose	1
POO776	POO776	EZ Grip Nut 3/8-16	2
SIP138	SIP138	Manifold	1
SIP139	SIP139	Support Hoop	1
SIP140	SIP140	Bag House Support Post	1
SLO320	SLO320	Bag House Hopper	1
SLO341	SLO341	Clean Out Gate	1

SI-LOW 206 H2 BAGHOUSE ASSEMBLY

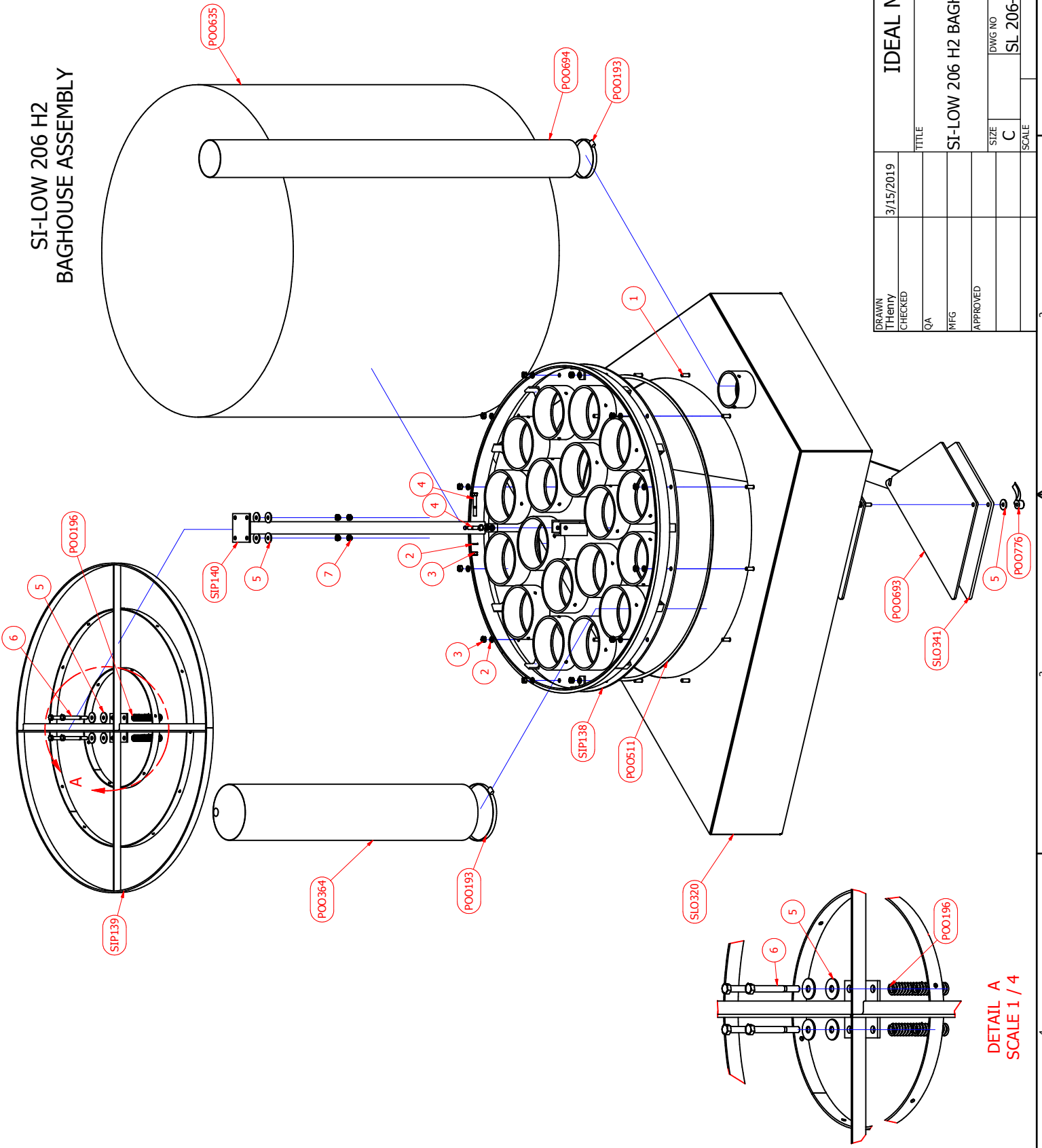

DRAWN T.Henry	3/15/2019	IDEAL MFG., INC.	
CHECKED QA		TITLE	
MFG		SI-LOW 206 H2 BAGHOUSE	
APPROVED		SIZE C	DWG NO SL 206-H2-208
		SCALE	REV
			SHEET 1 OF 1

DETAIL A
SCALE 1 / 4

Si-Low 206 H2
Optional Load Cells Adjustable Legs
Reference Drawing # 206 H2-209

ITEM	PART NUMBER	QTY	DESCRIPTION
1	F00190	8	M 24 X 2.0 X 1 1/4" Metric Hex Bolt
2	N/A	8	M 24 Lock Washer
3	N/A	8	1-8 X 3 1/2 Hex Bolt
4	N/A	8	1" Lock Washer
5	N/A	8	1-8 Hex Nut
6	N/A	2	10-24 X 3/4 Machine Screw
7	N/A	6	10-24 Hex Machine Screw Nut
8	N/A	6	# 10 Lock Washer
9	N/A	4	10-24 X 1/2 Machine Screw
10	F00189	8	SHIM
11	100246	4	LOAD CELL
12	POO716	1	WEIGHT INDICATOR
13	POO716A	1	SCALE MOUNT
14	POO910JB	1	JUNCTION BOX
15	LEG	4	ADJUSTABLE LEG
16	PIN	4	LEG PIN
17	POO770	4	HAIRPIN CLIP
18	N/A	4	Ground Jumper
19	N/A	8	1/4 Lock Washer
20	N/A	8	1/4-20 X 3/4 Hex Bolt

SI-LOW 206 H2
LOAD CELLS &
ADJUSTABLE LEGS
TANK NOT SHOWN FOR CLARITY

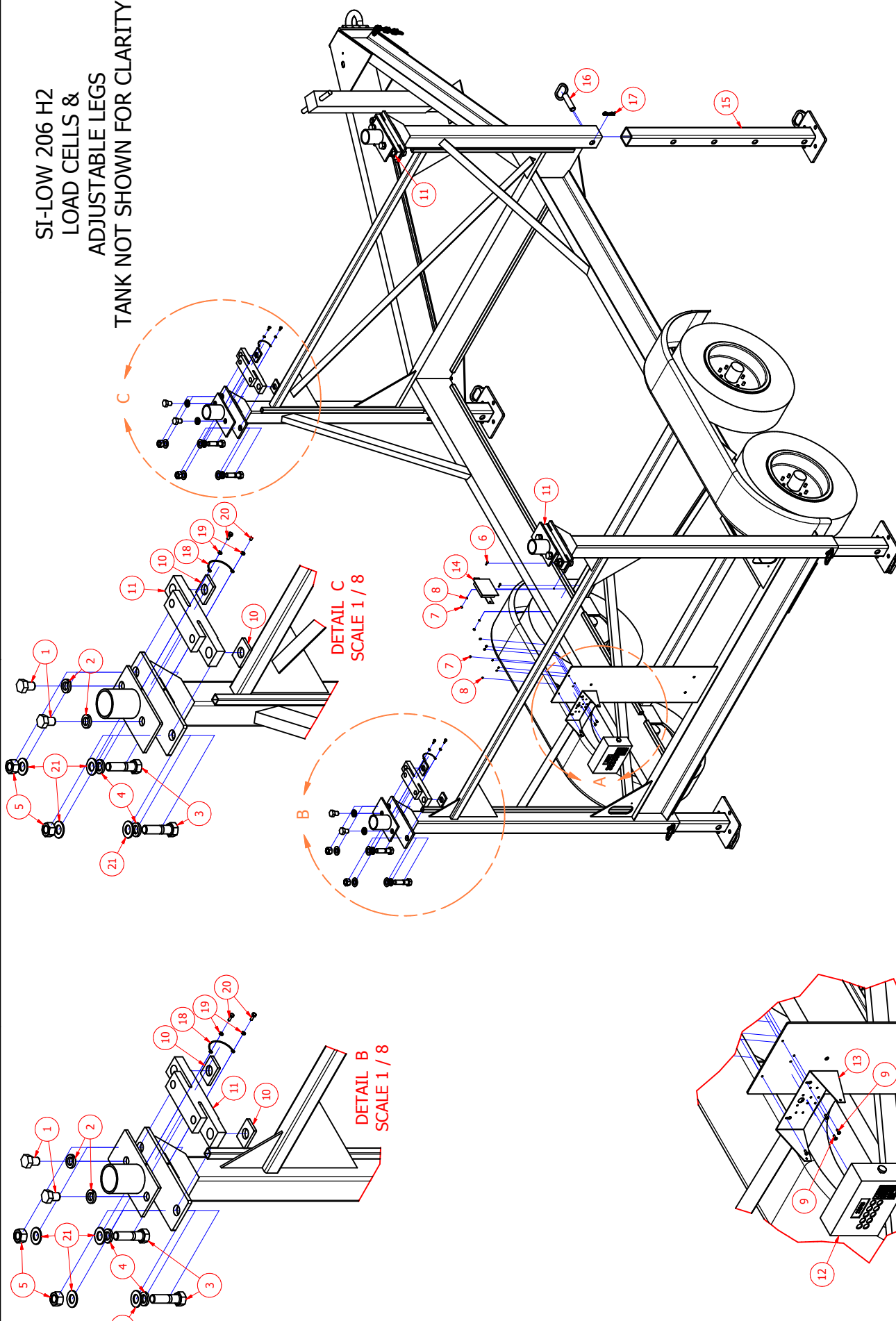

DETAIL C
SCALE 1 / 8

DETAIL B
SCALE 1 / 8

DETAIL A
SCALE 1 / 8

DRAWN T. Henry		12/12/2018	Ideal Mfg., Inc.	
CHECKED			2011 Harnish Blvd. Billings MT 59101	
QA			TITLE	
MFG			SI-LOW 206 H2 LOAD CELLS	
MATERIAL			SIZE	
MASS			DWG NO	
2522.4 lbmass			206 H2-209	
			SCALE	
			1 / 16	
			SHEET 1 OF 1	

PROJECTION
REMOVE ALL BURRS
UNLESS OTHERWISE SPECIFIED
DIMENSIONS ARE IN INCHES
TOLERANCES ARE:
.XX ± .01
.XXX ± .005
FRACTION ± 1/32
ANGLES ± 1'
DRILLED HOLE ± 1/64

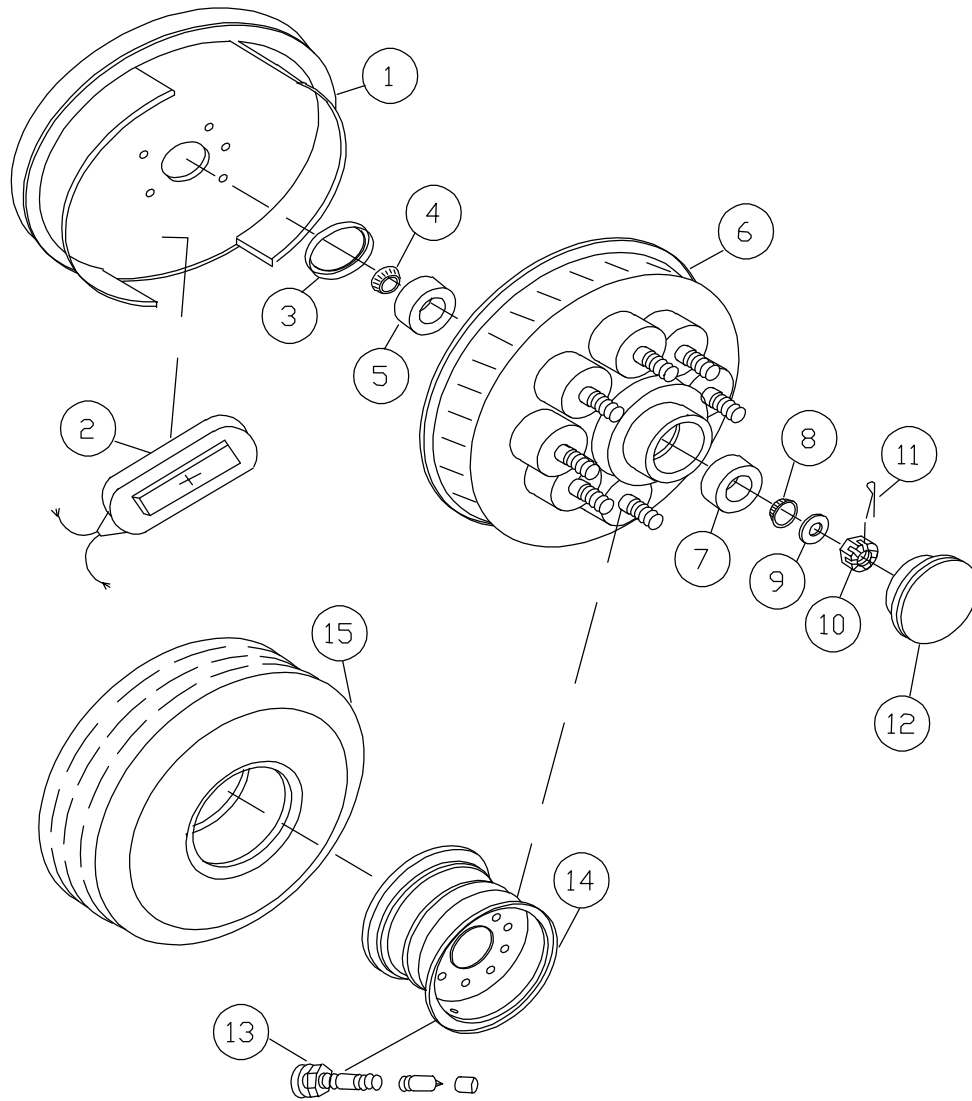

**Si-Low 206 H2
TRAILER WHEEL COMPONENTS**

REF NO.	PART NO.	DESCRIPTION	REQ NO
1	POO831	Right Brake Assembly	2
	POO832	Left Brake Assembly	2
2	POO833	Actuator Magnet Kit	4
3	POO834	Inner Grease Seal	4
4	POO835	Inner Bearing	4
5	POO836	Inner Bearing Race	4
6	POO837	Hub & Brake Drum	4
7	POO838	Outer Bearing Race	4
8	POO839	Outer Bearing	4
9	POO840	Spindle Washer	4
10	POO841	Spindle Nut	4
11	N/A	5/32 x 1 1/2" Cotter Pin	4
12	POO842	Dust Cap	4
13	POO843	Valve Stem Assembly	4
14	POO844	Tire Rim	4
15	POO845	Tire	4
16	POO846	Tire Rim Lug Bolts	32

PARTS LIST			
ITEM	PART NUMBER	QTY	DESCRIPTION
1	SLO322	1	MAN HOLE LID
2	SLO131	1	HINGE PIN
3	POO752	2	VALVE SEAL
4	N/A	1	RELIEF LID
5	SLO321	1	MAN HOLE FRAME (FACTORY INSTALLED)
6	N/A	1	Pin - Cotter 3/16 X 1
7	N/A	1	Pin - Cotter 1/4 X 3
8	POO511B	1	MAN HOLE GASKET
9	N/A	8	1/2-13 X 1 1/2 Hex Bolt
10	N/A	8	1/2 Lock Washer
11	N/A	8	1/2-13 Hex Nut

SI-LOW 206 H2 MAN HOLE

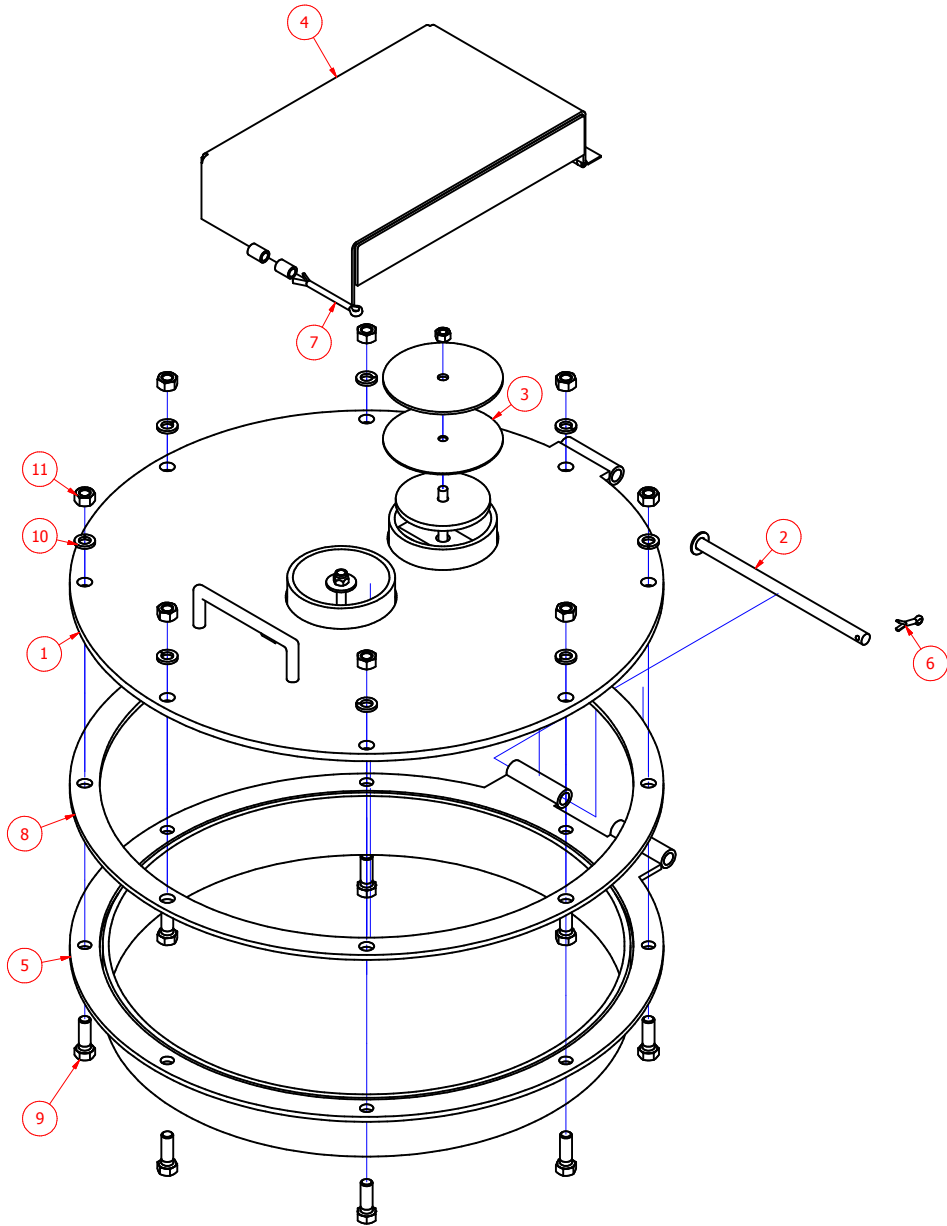

 PROJECTION REMOVE ALL BURRS UNLESS OTHERWISE SPECIFIED DIMENSIONS ARE IN INCHES TOLERANCES ARE: .XX ± .01 .XXX ± .005 FRACTION ± 1/2 ANGLES ± 1' DRILLED HOLE ± 1/4	DRAWN	T Henry	7/26/2019	Ideal Mfg., Inc. 2011 Harnish Blvd. Billings MT 59101 <small>TITLE</small>		
	CHECKED	QA				SI-LOW 206 H2 MAN HOLE
		MFG		SIZE	DWG NO	
		MATERIAL		C	SL 206-H2-211-M	
	MASS	94.3 lbmass	SCALE	1 / 4	SHEET 1 OF 1	

SI-LOW 206 H2 VIBRATOR & AERATION SYSTEM

REF. NO.	PART NUMBER	DESCRIPTION	QTY
1	N/A	3/4 SCH 40 PIPE X 28 1/2	1
2	N/A	Hex Bolt 1/2-13 X 5	2
3	N/A	Lock Washer 1/2	2
4	N/A	Hex Nut 1/2-13	2
5	PO0530	VIBRATOR 110 VAC	1
	PO0531	VIBRATOR 12 VDC	
	PO0781	VIBRATOR AIR PISTON	
	BKO151	1/2 POLY TUBE	12
	PO0429	1/4"NPT PLUG	1
	PO0665	3/4" BALL VALVE	1
	PO0673	AERATOR ASSEMBLY	6
	PO0674	EZ IN KIT	6
	PO0724	TUBE FITTING	6
	PO0725	TUBE FITTING	6
	PO0747	45 Deg Street Elbow	1

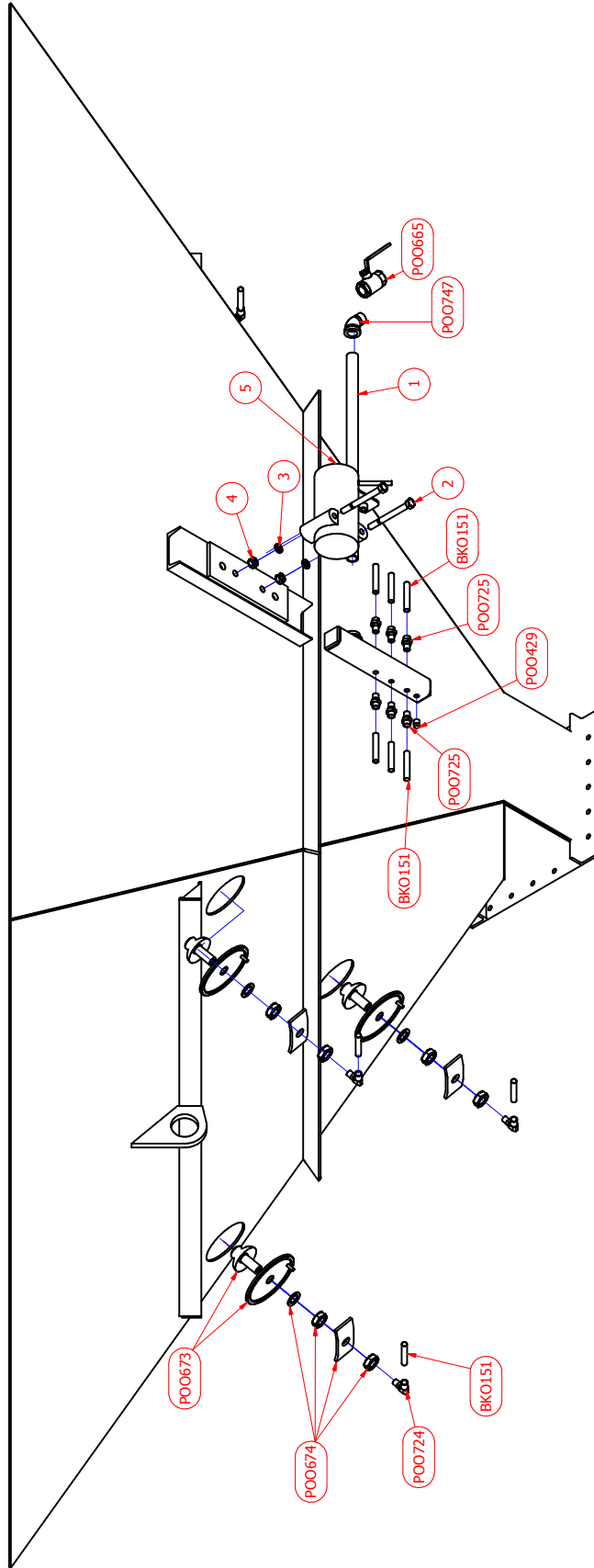

NOTE: See page 2 for wiring for 110 volt AC vibrator.
 NOTE: See page 31 for wiring for 12 volt dc vibrator.

DRAWN THenry	3/19/2019	IDEAL MFG., INC.
CHECKED		TITLE
QA		SI-LOW 206 H2 VIBRATOR & AERATION SYSTEM
MFG		SIZE
APPROVED		C
		DWG NO
		SL 206-H2-212
		SCALE
		REV
		1

Si-Low 206 H2
OPTIONAL CONTROL SYSTEM
 FOR GAS & DIESEL ENGINES
 see page 21 for electric motor

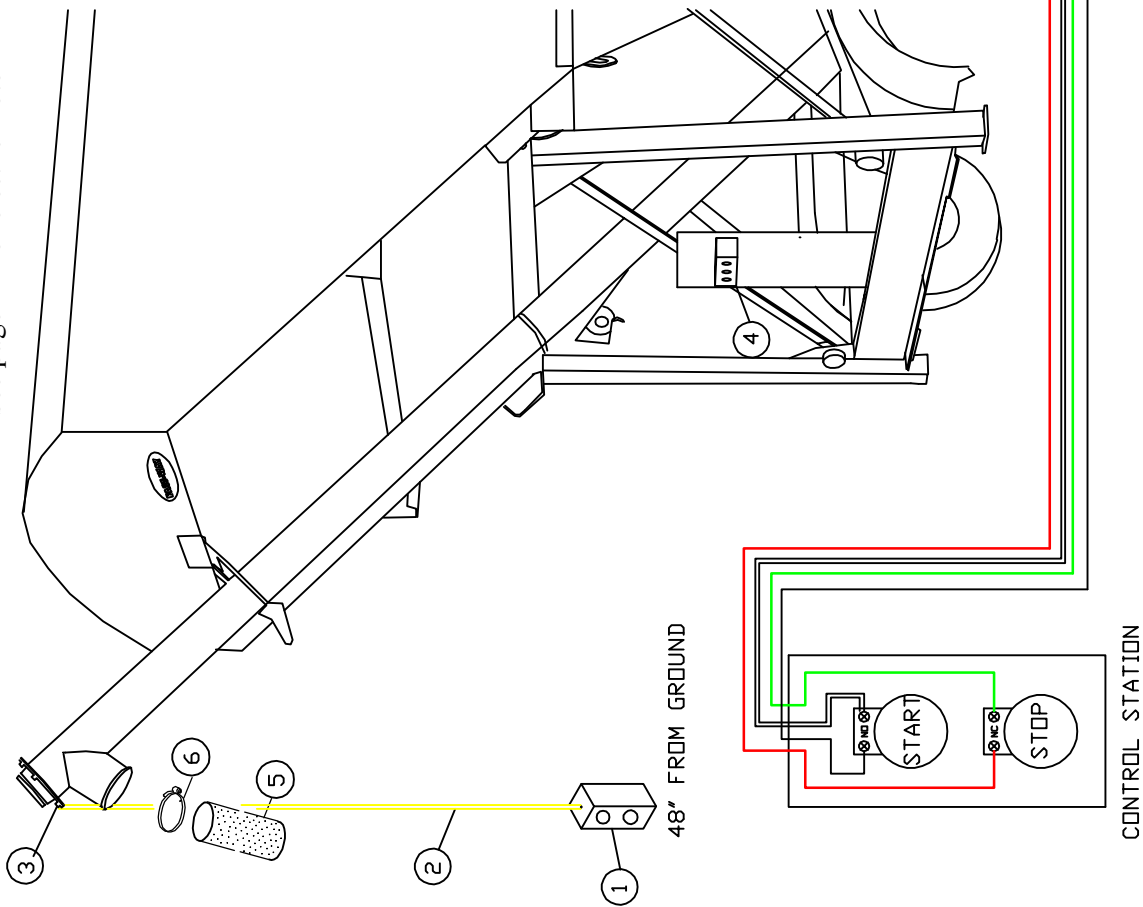

REF NO.	PART NO.	DESCRIPTION	REQ NO
1	POO772	Control Station	1
2	N/A	16/4 Electrical Wire 25'	1
3	N/A	DG-4 Clamp	2
4	POO983 / POO983A	Electrical Box 3 Hole / Electrical Box 2 Hole	1
5	POO122	Discharge Boot	1
6	POO121	Hose Clamp	1
7	PEO371	Relay 8 pin	1
8	PEO606A	Socket 8 pin	1
9	POO973	Switch	1
10	POO974	Switch	1
11	POO765	Switch (with optional 12 vdc vibrator)	1
12	N/A	Fuse Holder (with fuse 7 amp)	1

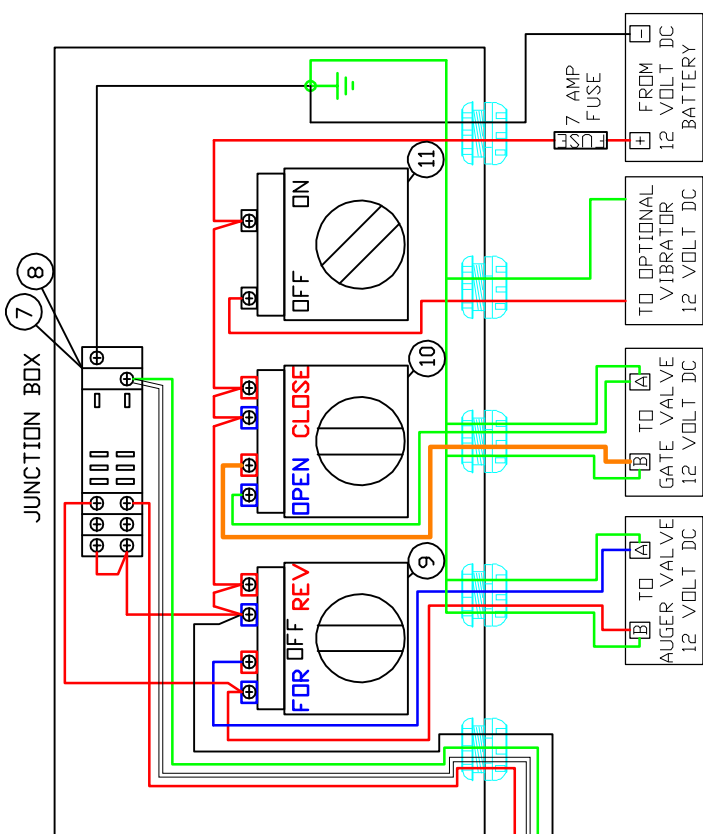

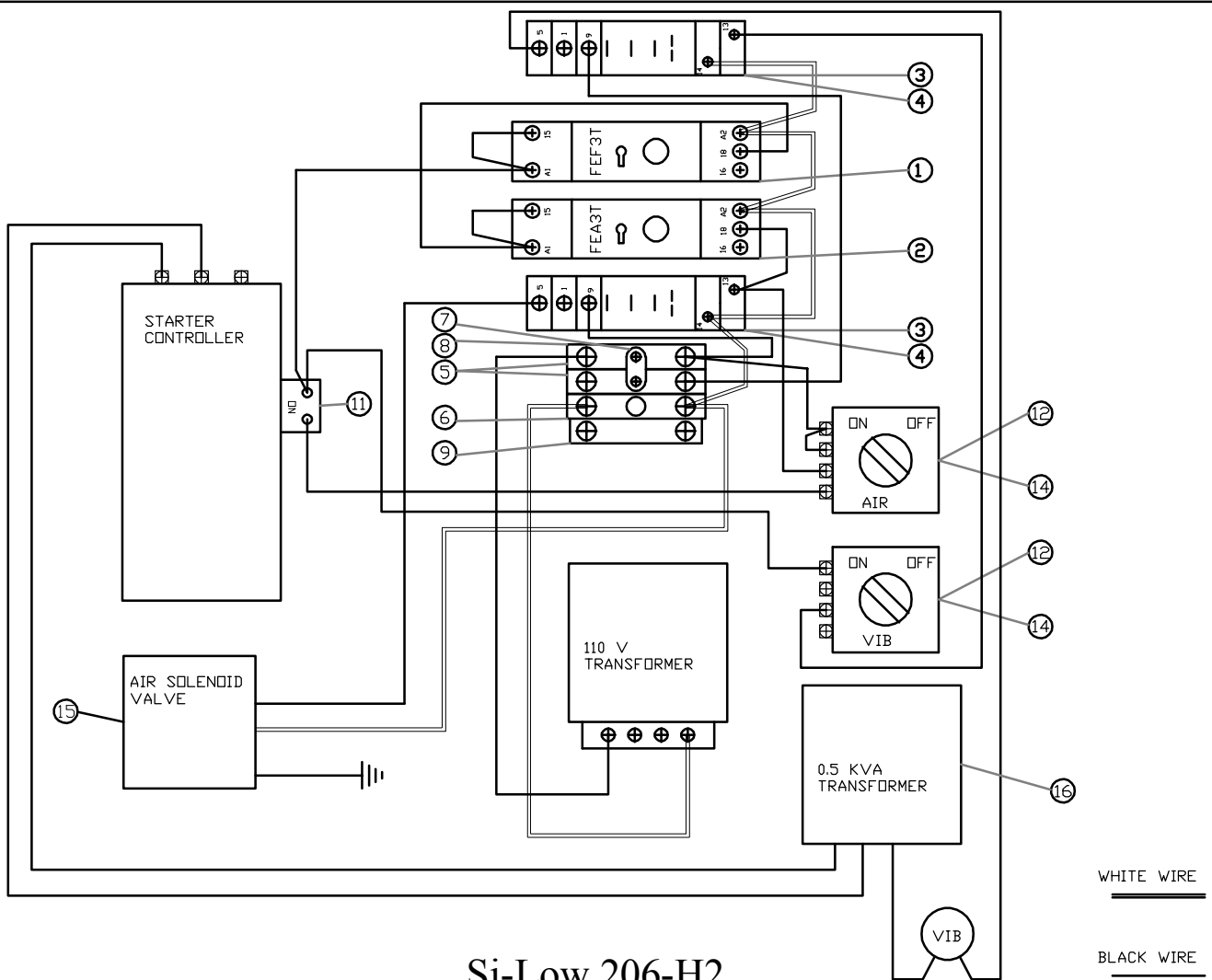

Si-Low 206-H2 VIBRATOR & OPTIONAL PULSE AERATION WIRING

REF NO.	PART NO.	DESCRIPTION	REQ NO
1	POO769	Timer FEF3TU23 (Set at 20 seconds)	1
2	POO769-1	Timer FEA3TU23 (Set at 2 Seconds)	1
3	POO778	Relay	2
4	PEO605-A	Socket Relay	2
5	PEO622	Terminal Block (Black)	2
6	PEO624	Terminal Block (Grey)	1
7	PEO632	Jumper 2 Block	1
8	PEO638	End Barrier	1
9	PEO620	End Anchor	1
10	PEO212	Din Track 4 1/2" (not shown)	1
11	POO771	Auxiliary Contact 595-AB	1
12	POO765	Select Switch 800T-H2D1	2
13			
14	POO766	Name Plate On/Off	2
15	POO768	Asco Air Valve 8210G95	1
16	PEO280	0.5 KVA TRANSFORMER	1

**SERVICE INSTRUCTIONS FOR THE WR [255 & 256] SERIES MOTORS**

For Use With Seal Kit: 255222001

dimensions: mm [in]

IMPORTANT NOTE: The WR(255/256) Series Motors depend on the correct orientation of parts as well as correct internal timing for proper motor operation. Before disassembling the motor, it is highly recommended that paint or a marker be used to make a "V" shaped set of lines from the endcover to the housing. This will aid in reassembling the motor components properly. It is also important that the steps involving internal parts timing be followed carefully to insure proper motor operation.

- A) Remove all shaft related components from shaft (15) (i.e. keys, nuts). To aid in reassembly of the motor, make a "V" shaped set of lines from the endcover (11) to the housing using either paint or a marker. With shaft facing down, secure motor in vise by clamping on to the housing (5).
- B) Loosen and remove seven bolts (14) holding motor assembly together. Remove endcover (11). Remove body seal (4) and discard seal. Remove rotor set assembly (9), & wear plate (8). Remove body seals (4) from rotor assembly (9) and housing (5) and discard seals. Remove drive link pin (10) and drive link (7) from motor and lay aside.
- C) Gently tap shaft (15) upward through housing (5) and remove through rear of housing. Remove housing (5) from vise. Collect thrust bearing and thrust washer from the rear of the housing while turning the housing over. Secure the housing in the vise with the flange end facing up. Gently pry dust seal (1) from housing using a small screwdriver and a hammer. Gently remove shaft seal (2) with a small screwdriver and discard it.

At this point, all parts should be cleaned in an oil-based solvent and dried using compressed air (For safety, observe all OSHA safety guidelines). All new seals should be lightly coated in clean oil prior to installation.

- D) Place shaft (15) on a clean flat surface with output end facing up. Place thrust bearing (6) then thrust washer (3) on the shaft. Install shaft seal (2) down onto shaft (15) making sure that lip on seal faces down. (See Figure (1) for shaft component orientation).

NOTE: To turn the WR Series Motors to proper operation, the rotation code of the motor must be known. The rotation code of the motor is 255 (standard) 256 (reverse timed) – the first 3 digits of the model code. If the rotational code is not known, and if port 'A' is pressurized, motors that are to have the shafts turning clockwise (as viewed from the shaft end) should be timed using the "255" series and motors that are to have the shafts turning counterclockwise (as viewed from shaft end) should be timed using the "256" series.

- E) Turn shaft (15) over so that output end of the shaft faces down. Lower drive link (7) into shaft making sure that the timing mark end of drive link faces up and that the timing mark on the end of the drive link (7) is aligned to the left of any short, open cutter slot on shaft (15).
- F) Turn housing (5) over so that the pilot of housing faces down and secure housing (5) in vise. Without disturbing the shaft seal (2), and drive link (7), carefully lower shaft assembly into housing. Apply pressure using an arbor press or a rubber mallet to make sure that the shaft end is flush or slightly lower than the housing bolt hole surface.
- G) Place a body seal (4) in groove in the rear surface of the housing (5). Place wear plate (8) on housing. Make sure that the seven valving slots on the wear plate line up with the seven bolt holes on the housing (5).
- H) Place a body seal (4) in the groove in the face of the rotor assembly (9). With the seal groove surface on the rotor assembly facing wear plate, lower rotor assembly (9) onto drive link (7) making sure that the timing mark on drive link is aligned with a peak on the rotor (9) for 256 series, or with a valley on the rotor (9) for 255 series (See Figure (2)). After assembling the rotor assembly on the drive link rotate the rotor assembly to line up the assembly bolt holes. Insert drive link pin (10) into end of drive link (7) making sure that concave or the indented end faces up.
- I) Place remaining body seal (4) in groove in endcover (11). Place endcover (11) onto motor making sure that end of drive link pin (10) is in hole in center of end cover (11). There is no specific orientation to assemble the end cover on the motor.
- J) Install one washer (13) on each bolt (14) from the threaded end side. Insert seven assembly bolts (14) with washers (13) into bolt holes and pre-torque to 13.6 Nm [10 ft. lb.]. Using a crisscross pattern, final torque bolts to 60 Nm [44 ft. lb.].
- K) Remove motor from vise and place on work surface with shaft (15) facing up. Making sure that lip on dust seal (1) faces up, place dust seal (1) over shaft (15). Using a sleeve and hammer, carefully drive dust seal (1) into place.

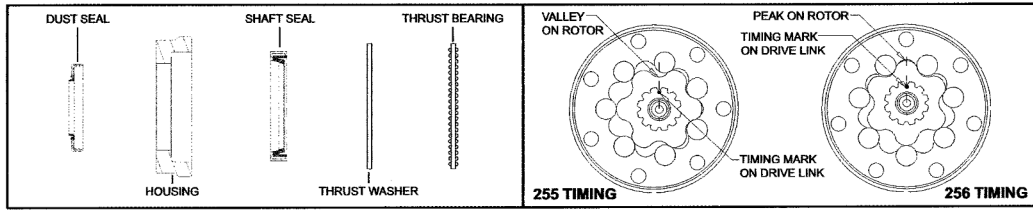
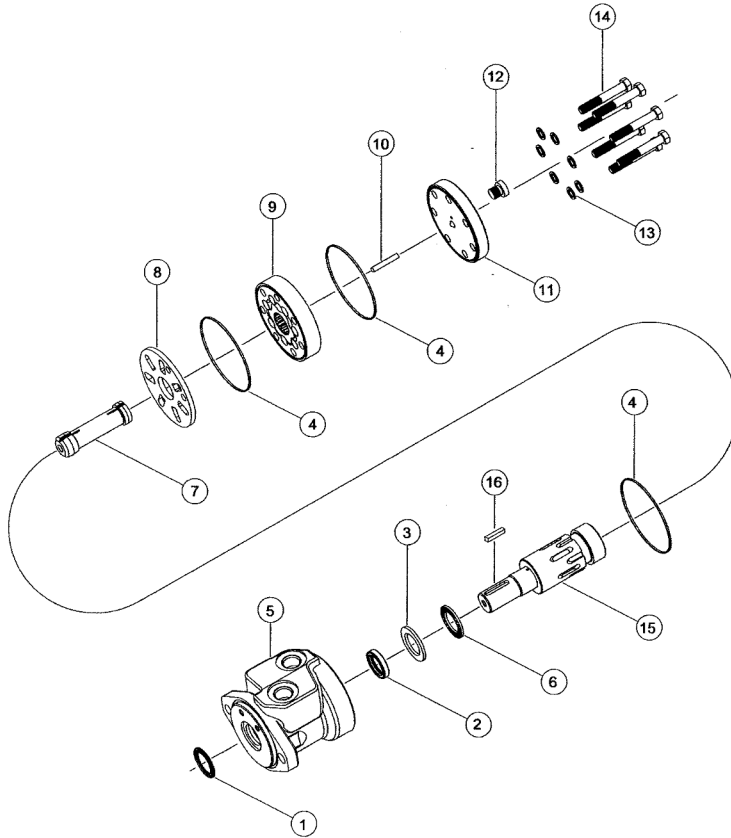

FIGURE 1

FIGURE 2



- 1. * Dust Seal
- 2. * Shaft Seal
- 3. * Thrust Washer
- 4. * Body Seals (3)
- 5. Housing
- 6. Thrust Bearing
- 7. Drive Link
- 8. Wear Plate
- 9. Rotor Assembly
- 10. Drive Link Pin
- 11. Endcover
- 12. Endcover Plug
- 13. Assembly Bolt Washers (7)
- 14. Assembly Bolts (7)
- 15. Shaft
- 16. Shaft Key

* Contained in Seal Kit 255222001

WR (255) SERIES MOTOR

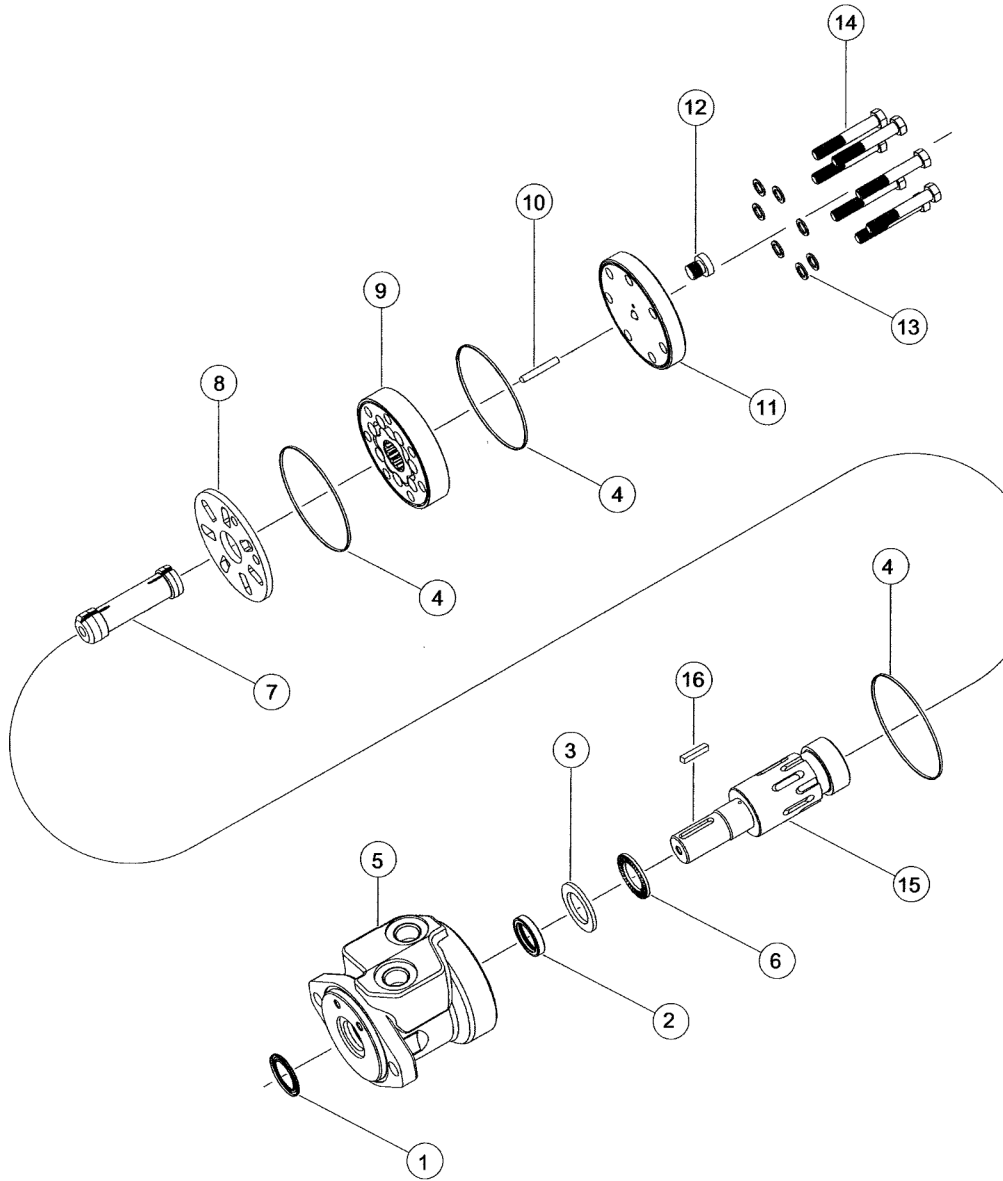

WR (255) SERIES MOTOR COMPONENTS

SEAL KIT 255222001

DESCRIPTION	EXP VIEW ITEM #	KIT
DUST SEAL	1	ITEMS #1-4 INCLUDED IN SEAL KIT: 255222001
SHAFT SEAL	2	
THRUST WASHER	3	
BODY SEALS (3)	4	
		255222001EG - SEAL KIT INCLUDES ITEM #1-4 SHAFT SEAL IS VITON

MISCELLANEOUS KITS

DESCRIPTION	EXPLODED VIEW ITEM #	KIT
THRUST BEARING	6	255018011
WEAR PLATE	8	255012001
ENDCOVER WITH BSP.F DRAIN	11	255016004
ENDCOVER WITH SAE DRAIN	11	255016005
SAE STEEL PLUG	12	500018186
BSP.F STEEL PLUG	12	300018084
BOLT WASHER SET	13	255018701
1000 PSI RELIEF VALVE	NOT SHOWN	500018228
2000 PSI RELIEF VALVE	NOT SHOWN	500018231
3/4-28 SLOTTED NUT	NOT SHOWN	200229300
3/4-28 LOCK NUT	NOT SHOWN	200018077

ROTORS, DRIVE LINKS AND SPACERS, AND BOLTS

WHEN CHANGING MOTOR DISPLACEMENTS, A MATCHING DRIVE LINK KIT, DRIVE LINK PIN KIT, AND BOLT SET KIT MUST ALSO BE ORDERED.

EXPLODED VIEW ITEM #	9	9	7	10	14
DISPLACEMENT	STANDARD ROTOR KIT	FREETURN ROTOR KIT	DRIVE LINK KIT	DRIVE LINK PIN KIT	BOLT SET KIT
040	255027003	---	200014002	200224003	255018101
060	255037003	---	200014002	200224008	255018102
070	255047003	---	200014001	200224005	255018102
090	255057003	---	200014001	200224006	255018103
100	255997003	---	200014001	200224008	255018103
115	255077003	---	200014003	200224008	255018104
130	255087003	---	200014003	200224010	255018104
160	255107003	---	200014003	200224012	255018105
200	255127003	---	200014003	200224014	255018106
240	255147003	---	200014003	200224018	255018107
320	255207003	---	200014003	200224024	255018108
400	255247003	---	200014003	255018019	255018109

HOUSING KITS

(EXPLODED VIEW ITEM #5)

BECAUSE THE HOUSING AND SHAFT ARE MATCH GROUND AS A SET TO EXTREMELY TIGHT TOLERANCES AT THE FACTORY, WHITE DRIVE PRODUCTS DOES NOT RECOMMEND THAT INDIVIDUAL HOUSINGS OR SHAFTS BE ORDERED TO REPAIR A MOTOR. IT IS RECOMMENDED THAT A MATCHED SET BE ORDERED. TO ORDER A MATCHED HOUSING/SHAFT KIT, PLEASE CONTACT A WHITE DRIVE PRODUCTS CUSTOMER SERVICE REPRESENTATIVE

DESCRIPTION	HOUSING KIT	DESCRIPTION	HOUSING KIT
#A63 - 2-HOLE OFFSET MANIFOLD 1/2" BSP.F (TP)	255013101	#A33 - 4-HOLE OFFSET MANIFOLD 1/2" BSP.F	255013127
#A62 - 2-HOLE MANIFOLD 1/2" BSP.F (TP)	255013102	#F33 - 4-HOLE OFFSET MANIFOLD 1/2" BSP.F	255013116
#A62 - 2-HOLE MANIFOLD 1/2" BSP.F (TP) W/RELIEF	255013103	#F38 - 4-HOLE ALIGNED PORTS 1/2" BSP.F	255013117
#A13 - 2-HOLE OFFSET MANIFOLD 1/2" BSP.F	255013105	#F30 - 4-HOLE ALIGNED PORTS 1/2" NPT	255013118
#A12 - 2-HOLE OFFSET PORTS 1/2" BSP.F	255013106	#F37 - 4-HOLE MANIFOLD PORTS	255013119
#A14 - 2-HOLE OFFSET MANIFOLD 7/8" O-RING	255013107	#G37 - 4-HOLE MANIFOLD PORTS METRIC TAP	255013120
#A11 - 2-HOLE FRONT PORTS 7/8" O-RING	255013109	#F39 - 4-HOLE 7/8" O-RING PORTS W/RELIEF	255013121
#A10 - 2-HOLE FRONT PORTS 7/8" O-RING	255013110	#F31 - 4-HOLE ALIGNED PORTS 7/8" O-RING	255013122
#A17 - 2-HOLE MANIFOLD PORTS 1/2" DRILLED	255013111	#F30 - 4-HOLE OFFSET MANIFOLD 7/8" O-RING	255013123
#AC3 - 4-HOLE OFFSET MANIFOLD 1/2" BSP.F (TP)	255013112	#G38 - 4-HOLE ALIGNED 1/2" BSP.F METRIC TAP	255013126
#A3D - 4-HOLE OFFSET MANIFOLD 7/8" O-RING	255013113	#B11 - 2-HOLE ALIGNED PORTS 7/8" O-RING	255013124
#A31 - 4-HOLE FRONT PORTS 7/8" O-RING	255013114	#B18 - 2-HOLE ALIGNED PORTS 1/2" BSP.F	255013125
#A30 - 4-HOLE FRONT PORTS 1/2" NPT	255013115		

SHAFTS AND RELATED COMPONENTS KITS

SHAFT KITS COME WITH RELATED SHAFT COMPONENTS (i.e. keys, nuts, etc.) TO ORDER INDIVIDUAL KEYS, USE THE KEY KIT NUMBER. TO ORDER NUT KITS (FOR #13 SHAFT), SEE MISCELLANEOUS KITS LIST ABOVE.

EXPLODED VIEW ITEM #	15	16
DESCRIPTION	SHAFT KIT	KEY KIT
#05- 1" WITH .373 PINHOLE	255011004	---
#53- 1" WITH .406 PINHOLE	255011005	---
#10- 1" STRAIGHT (5/16-18 UN TAP)	255011001	255018200
#02- 6-B SPLINE (5/16-18 UN TAP)	255011008	---
#01- 13 TOOTH SPLINE	255011011	---
#12- 25MM STRAIGHT	255011006	255018201
#13- 1" TAPERED	255011013	255018203
#B1- 25MM STRAIGHT W/ WOODRUFF KEY	255011016	255018205
#04- 6-B SPLINE (M6x1.25 TAP)	255011009	---
#98- 1" STRAIGHT (3/8-16UNC-2B)	255011017	255018200
#66- 1" WITH 8MM PINHOLE	255011003	---
#15- 1" STRAIGHT SPEED SENSOR	255011014	255018200
#16- 25MM STRAIGHT SPEED SENSOR	255011015	255018201
#11- 1" STRAIGHT (M8x1.25 TAP)	255011002	255018200

HOUSING/SHAFT KITS

HOUSING/SHAFT KITS COME WITH ITEMS 5, 15, & 16

TO ORDER A MATCHED HOUSING/SHAFT KIT, PLEASE CONTACT A WHITE DRIVE PRODUCTS CUSTOMER SERVICE REPRESENTATIVE.

Specifications & Ratings

General	
Construction	external gear-type pump
Mounting	flange or through-bolting with pilot
Line connections	screw, flange
Direction of rotation (Fig. 4)	clockwise or counter-clockwise The pump may only be driven in the direction indicated.
Mounting position	any
Ambient temperature range	-15 °C to +60 °C (+5°F to 140°F)
Fluid	mineral oil-based hydraulic fluids to DIN/ISO, other fluids to order
Viscosity – centistokes (mm ² /s)	12 ... 800 mm ² /s permitted range 20 ... 100 mm ² /s recommended range ... 2000 mm ² /s max. cold start
Fluid temperature range	-15 °C to +80 °C (+5°F to 176°F)
Filter **) (further informations see page 27)	contamination class 10 to NAS 1638 obtained with filter β ₂₅ = 75

**) During the application of control systems or devices with critical counter-reaction, such as steering and brake valves, the type of filtration selected must be adapted to the sensitivity of these devices/systems.

Safety requirements pertaining to the whole system are to be observed.

In the case of applications with high numbers of load cycles please check.

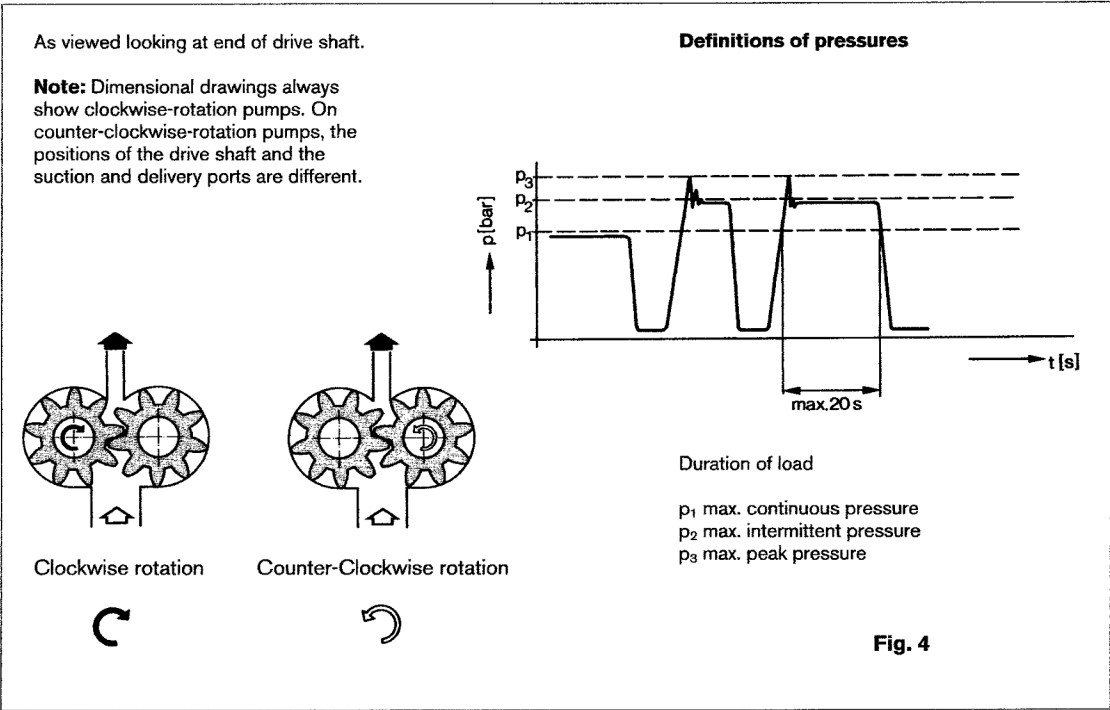

Notes on installation

Further information
see "General operating and
Maintenance Instructions".
☎ 1 987 762 101

Installation and commissioning

- Fill the pump with fluid before installing.
- Check the direction of rotation.
- Before installing the pump, clean the pipes thoroughly of all dirt, scale, sand, swarf, etc. Welded pipes in particular must be pickled or flushed out.
- Before starting up the pump for the first time, the entire hydraulic system must be thoroughly purged of air.
- Cover the shaft seal when spraying or brush-painting the equipment.
- Pay close attention to the specification, especially speeds, pressures and suction vacuum.

Filter recommendations

By far the largest number of premature failures to gear pumps are due to contaminated fluid.

Since our guarantee does not apply to wear resulting from dirt in the system, we recommend filtering, which reduces the size and concentration of the contamination particles to a permitted minimum.

Operating pressure [bar]	>160	<160
Contamination class NAS 1638	9	10
Contamination class ISO 4406	18/15	19/16
Achieved with filter $\beta_x = 75$	20	25

Fig. 6

Full-flow filtering is always recommended.

The initial contamination of the fluid with which the system is filled must not exceed Class 10 to NAS 1638. Past experience has shown that even brand new fluids often exceed this value. In such cases a filter incorporating a special element will have to be used.

Drive arrangements

1. Flexible couplings

The coupling must not transfer any radial or axial forces to the pump.

The maximum radial runout of shaft pilot is 0.2 mm. Refer to the fitting instructions provided by the coupling manufacturer for details of the maximum permitted shaft misalignment.

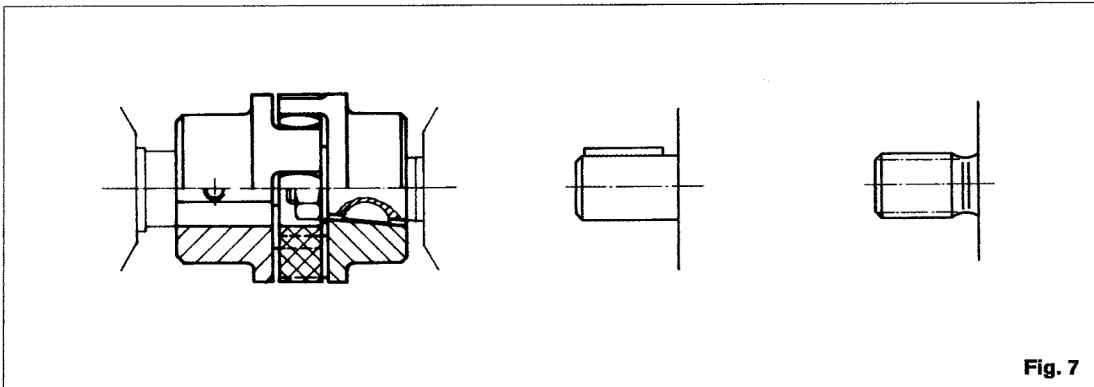
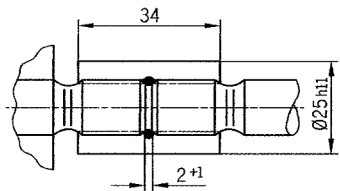

Fig. 7

2. Sleeve couplings

Used on shafts with DIN or SAE splining. **Note:** There must be no radial or axial forces exerted on the pump or sleeve coupling. The sleeve must be free to move axially. The distance between the pump shaft and drive shaft must be 2^{+1} . Oil-bath or oil-mist lubrication is necessary.



Size
B 17 x 14 DIN 5482
 $M_{max} = 190 \text{ Nm}$

3. Tang Drive (Ref. Fig. 8 & 9)

For the close-coupling of pumps to engines, gearboxes, etc. the pump shaft has a special drive dog which combines with a center coupling ③ (included with the pumps). There is no shaft seal.

The recommended arrangements and dimensions for the drive end and sealing are as follows.

① **Drive shaft**

Case-hardening steel DIN 17 210
 e.g. 20 Mn CrS 5
 case-hardened 0.6 deep; HRC 60 ±3.
 Surface for sealing ring
 ground without rifling $R_t \leq 4\mu\text{m}$

② **Radial shaft seal**

Rubber-covered seal (see DIN 3760, Type AS or double-lipped ring).
 Cut 15° chamfer or fit shaft seal with protective sleeve.

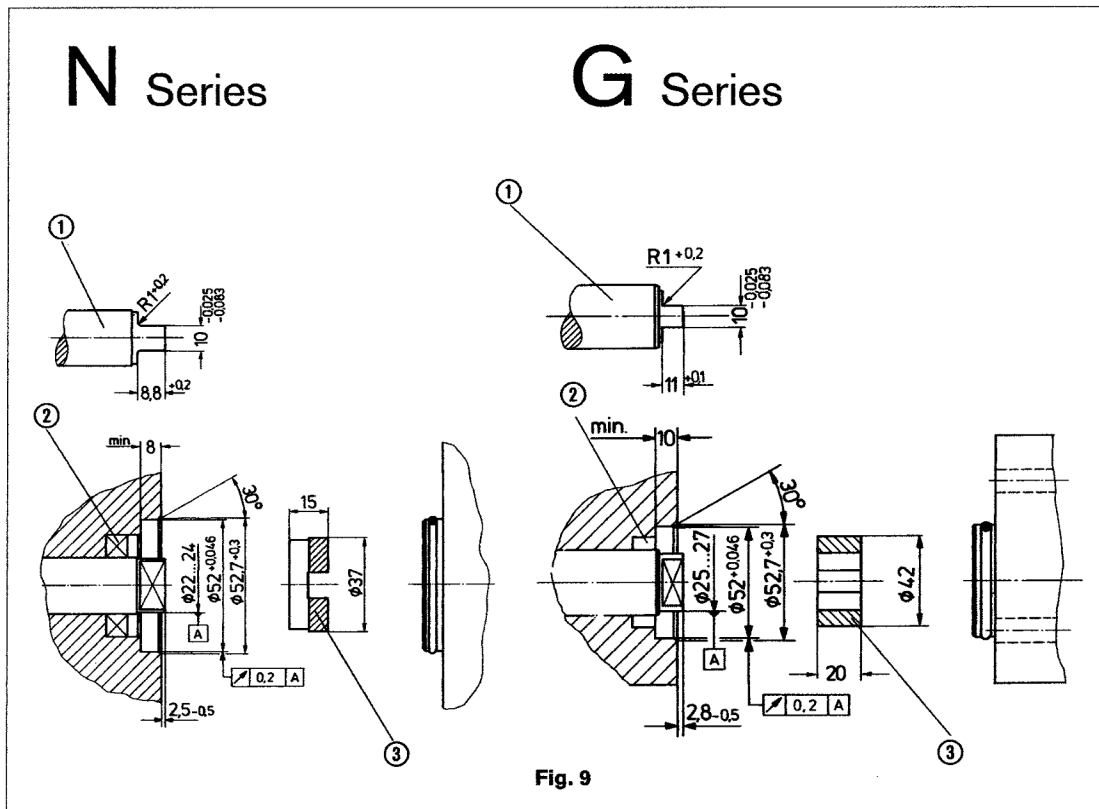
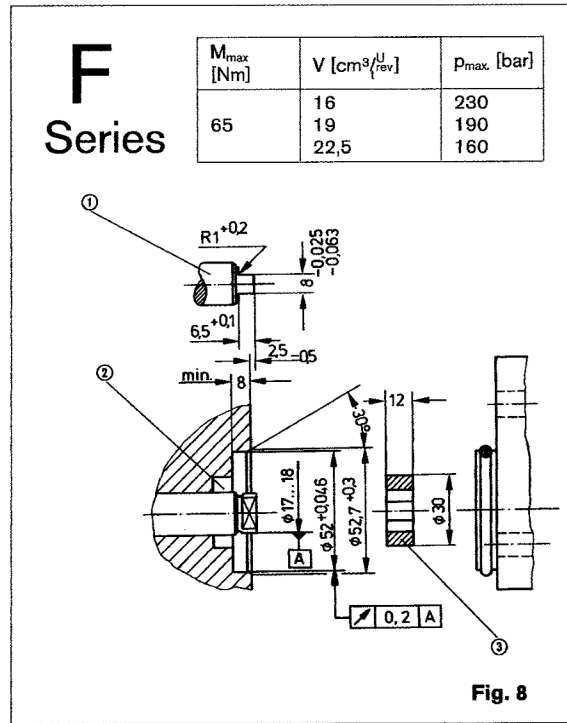

SI-LOW 206 H2 SLIDE GATE ASSEMBLY

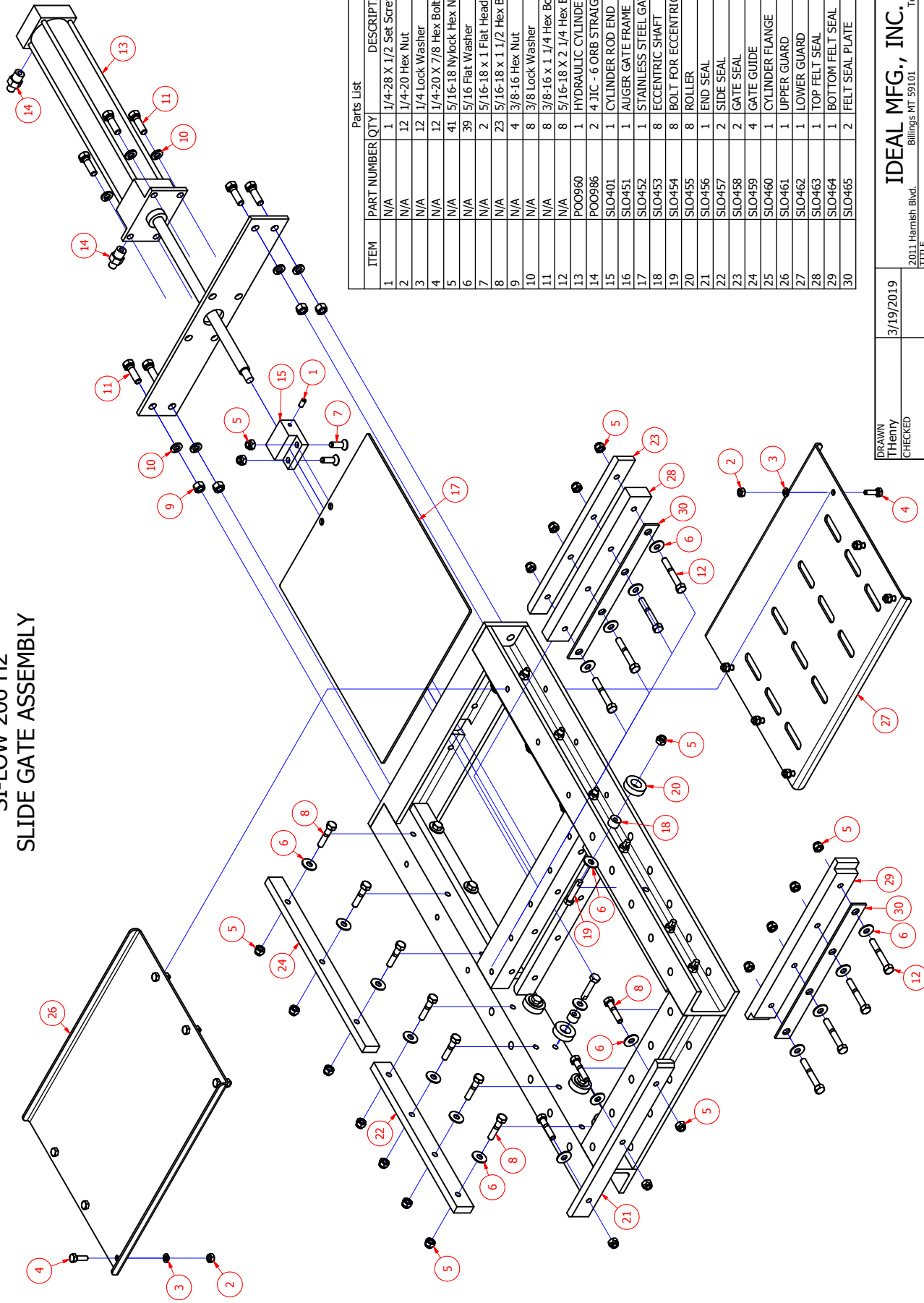

ITEM	PART NUMBER	QTY	DESCRIPTION
1	N/A	1	1/4-28 X 1/2 Set Screw
2	N/A	12	1/4-20 Hex Nut
3	N/A	12	1/4 Lock Washer
4	N/A	12	1/4-20 X 7/8 Hex Bolt
5	N/A	41	5/16-18 Nylock Hex Nut
6	N/A	39	5/16 Flat Washer
7	N/A	2	5/16-18 x 1 Flat Head Cap Screw
8	N/A	23	5/16-18 x 1 1/2 Hex Bolt
9	N/A	4	3/8-16 Hex Nut
10	N/A	8	3/8 Lock Washer
11	N/A	8	3/8-16 x 1 1/4 Hex Bolt
12	N/A	8	5/16-18 X 2 1/4 Hex Bolt
13	POO960	1	HYDRAULIC CYLINDER
14	POO986	2	4 JIC - 6 ORB STRAIGHT
15	SLO401	1	CYLINDER ROD END
16	SLO451	1	AUGER GATE FRAME
17	SLO452	1	STAINLESS STEEL GATE
18	SLO453	8	ECCENTRIC SHAFT
19	SLO454	8	BOLT FOR ECCENTRIC SHAFT
20	SLO455	8	ROLLER
21	SLO456	1	END SEAL
22	SLO457	2	SIDE SEAL
23	SLO458	2	GATE SEAL
24	SLO459	4	GATE GUIDE
25	SLO460	1	CYLINDER FLANGE
26	SLO461	1	UPPER GUARD
27	SLO462	1	LOWER GUARD
28	SLO463	1	TOP FELT SEAL
29	SLO464	1	BOTTOM FELT SEAL
30	SLO465	2	FELT SEAL PLATE

3/19/2019	IDEAL MFG., INC.	2011 Hamish Blvd.	Billings MT 59101	Rel. (406) 656-4360
DRAWN T.Henry	TITLE			
CHECKED	QA			
	MFG			
	APPROVED			
	SIZE	DWG NO	REV	
	C	SL 206-H2-215-1		
	SCALE	SHEET 1 OF 1		

440 / 460 VOLT THREE PHASE WITH OPTIONAL REMOTE CONTROL

COMBINATION STARTER
513-BJB-A2G-1-40-6P
5 HP 3 PHASE 440 V
NEMA SIZE 1
15 AMP CIRCUIT BREAKER

500 F-BDD 930 STARTER
592-EEEC OVERLOAD RELAY
1497-B-BASX-3N TRANSFORMER
PRIMARY FUSE 1 AMP/KLDR
SECONDARY FUSE .75 AMP/FLM
ENCLOSURE SIZE

10"W X 26 3/8"H X 8 7/32" DEEP
TRANSFORMER
.500 KVA #PE0280
DOUBLE FUSE HOLDER
F1 FUSE 3A 600V
#PE0931
FUSE #PE0932

SINGLE FUSE HOLDER
#PE0933
F2 FUSE 6.25A 250V
FUSE #PE0934

SWITCH FOR/OFF/REV
#P00973

SWITCH OPEN/CLOSE
#P00974

SWITCH OFF/ON
#P00765

OPTIONAL EQUIPMENT
FOR REMOTE START AND STOP

RADIO RECEIVER MODEL 850LM
#PE0272

RADIO TRANSMITTER 3-BUTTON 813LM
#PE0272B

8 PIN RELAY 24 VAC
#PE0606

8 PIN RELAY SOCKET
#PE0606A

TRANSFORMER
40 VA #PE0213

SINGLE FUSE HOLDER
#PE0933
F3 FUSE 1A 250V
FUSE #PE0625A

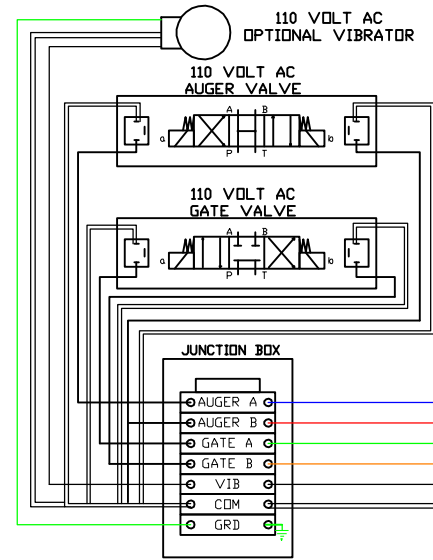

JUNCTION BOX # P00956
END ANCHOR # PE0620
TERM BLOCK GREEN/YELLOW # PE0621
TERM BLOCK BLACK # PE0622
TERM BLOCK RED # PE0623

TERM BLOCK GREY # PE0624
TERM BLOCK BROWN # PE0644
TERM BLOCK YELLOW # PE0645
TERM BLOCK ORANGE # PE0646
DIN TRACK 4 3/4" # PE0637

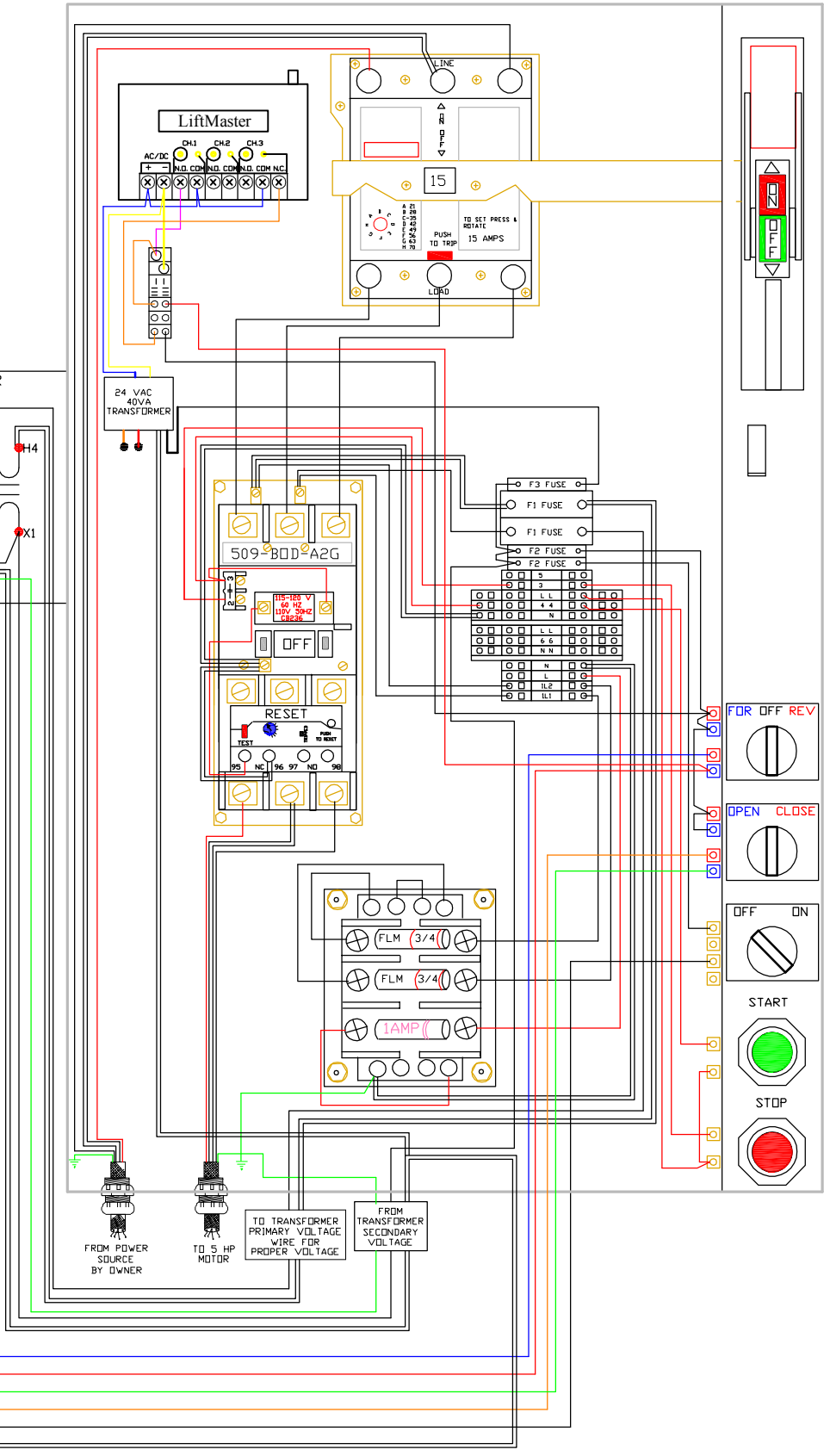

LEGEND

- WHITE
- RED
- BLACK
- GREEN

REVISIONS		
NO	DATE	DESCRIPTION

IDEAL MANUFACTURING INC.
2011 HARNISH BLVD, BILLINGS MT, 59101
PHONE: (406)506-4300 FAX: (406)506-4363

S1-Low 206 H2
ELECTRICAL CONTROL PANEL
WITH REMOTE CONTROL

440 / 460 VOLT 3 PHASE
PRIMARY 110 V SECONDARY

3-14-2019

208 / 240 VOLT SINGLE PHASE WITH OPTIONAL REMOTE CONTROL

COMBINATION STARTER
513-CJA-XXX-1-6P-42
5 HP SINGLE PHASE 240 V
NEMA SIZE 1
50 AMP CIRCUIT BREAKER

509 F-BDD 930 STARTER
5925-EEUD 18-90 AMP OVERLOAD RELAY
1497-N2PK 80 VA TRANSFORMER
PRIMARY FUSE 1 AMP/KLDR
SECONDARY FUSE .75 AMP/FLM
ENCLOSURE SIZE
10"W X 26 3/8"H X 8 7/32" DEEP

TRANSFORMER
.500 KVA #PED280
DOUBLE FUSE HOLDER
F1 FUSE 3A 600V

FUSE #PED932
SINGLE FUSE HOLDER

F2 FUSE 6.25A 250V
FUSE #PED934

SWITCH FOR/OFF/REV

SWITCH OPEN/CLOSE

SWITCH OFF/ON

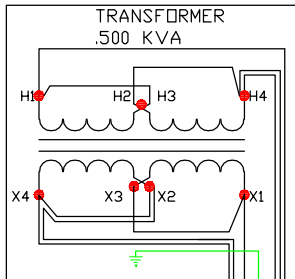

OPTIONAL EQUIPMENT FOR REMOTE START AND STOP

RADIO RECEIVER MODEL 850LM
#PED272
RADIO TRANSMITTER 3-BUTTON 813LM
#PED272B
8 PIN RELAY 24 VAC
#PED606
8 PIN RELAY SOCKET
#PED606A
TRANSFORMER
40 VA #PED213
SINGLE FUSE HOLDER
#PED933
F3 FUSE 1A 250V
FUSE #PED625A

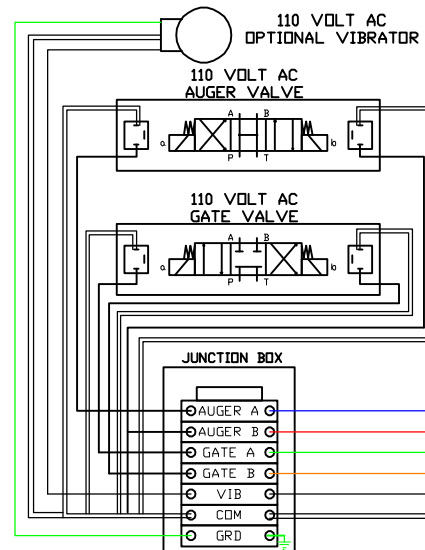

JUNCTION BOX # PDD956
END ANCHOR # PED620
TERM BLOCK GREEN/YELLOW # PED621
TERM BLOCK BLACK # PED622
TERM BLOCK RED # PDD623

TERM BLOCK GREY # PED624
TERM BLOCK BROWN # PED644
TERM BLOCK YELLOW # PED645
TERM BLOCK ORANGE # PED646
DIN TRACK 4 3/4" # PED637

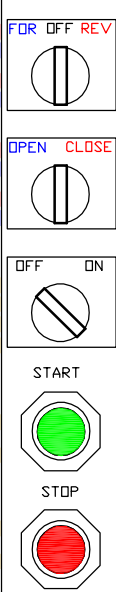
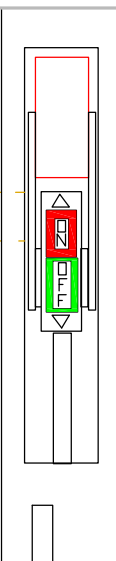
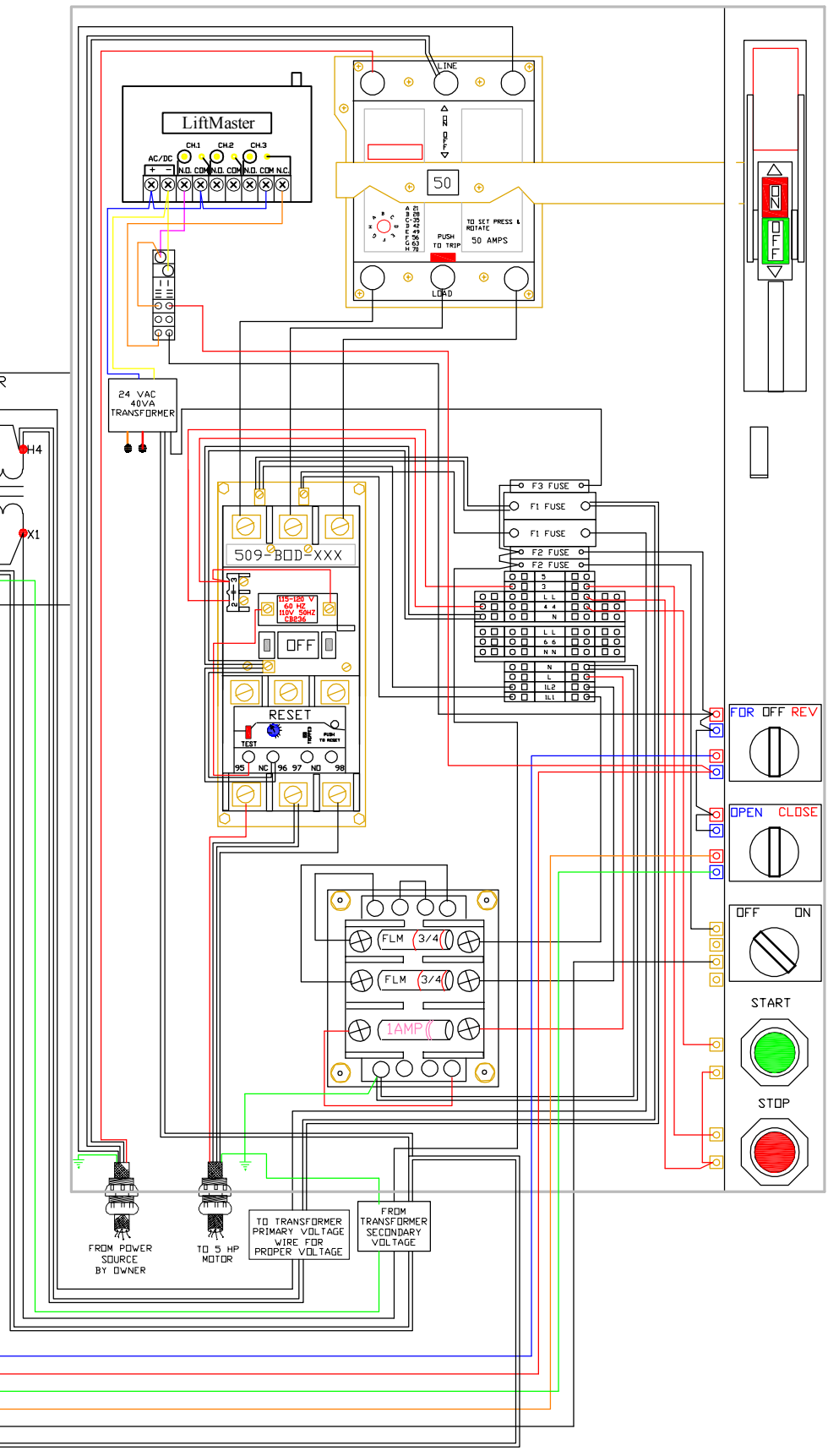

REVISIONS			IDEAL MANUFACTURING INC.	
NO	DATE	DESCRIPTION	281 HARRISON BLVD, BILLINGS MT 59103 PHONE: (406)656-4260 FAX: (406)656-4263	
			Si-Low 206 H2	
			ELECTRICAL CONTROL PANEL WITH REMOTE CONTROL	
			240 VOLT SINGLE PHASE ACAD PRIMARY 110 V SECONDARY T184	
			3-14-2019	

Si-Low 206 H2
 OPTIONAL REMOTE CONTROL SYSTEM
 FOR GAS & DIESEL ENGINES

REF NO.	PART NO.	DESCRIPTION	REQ NO
1	PEO272	Radio Receiver Model 850LM	1
2	PEO272B	Radio Transmitter 3-Button 813LM	1
3	POO983 / POO983A	Electrical Box 3 Hole / Electrical Box 2 Hole	
4	PEO371	Relay 8 pin	1
5	PEO606A	Socket 8 pin	1
6	POO973	Switch	1
7	POO974	Switch	1
8	POO765	Switch (with optional 12 vdc vibrator)	1
9	N/A	Fuse Holder (with fuse 7 amp)	1

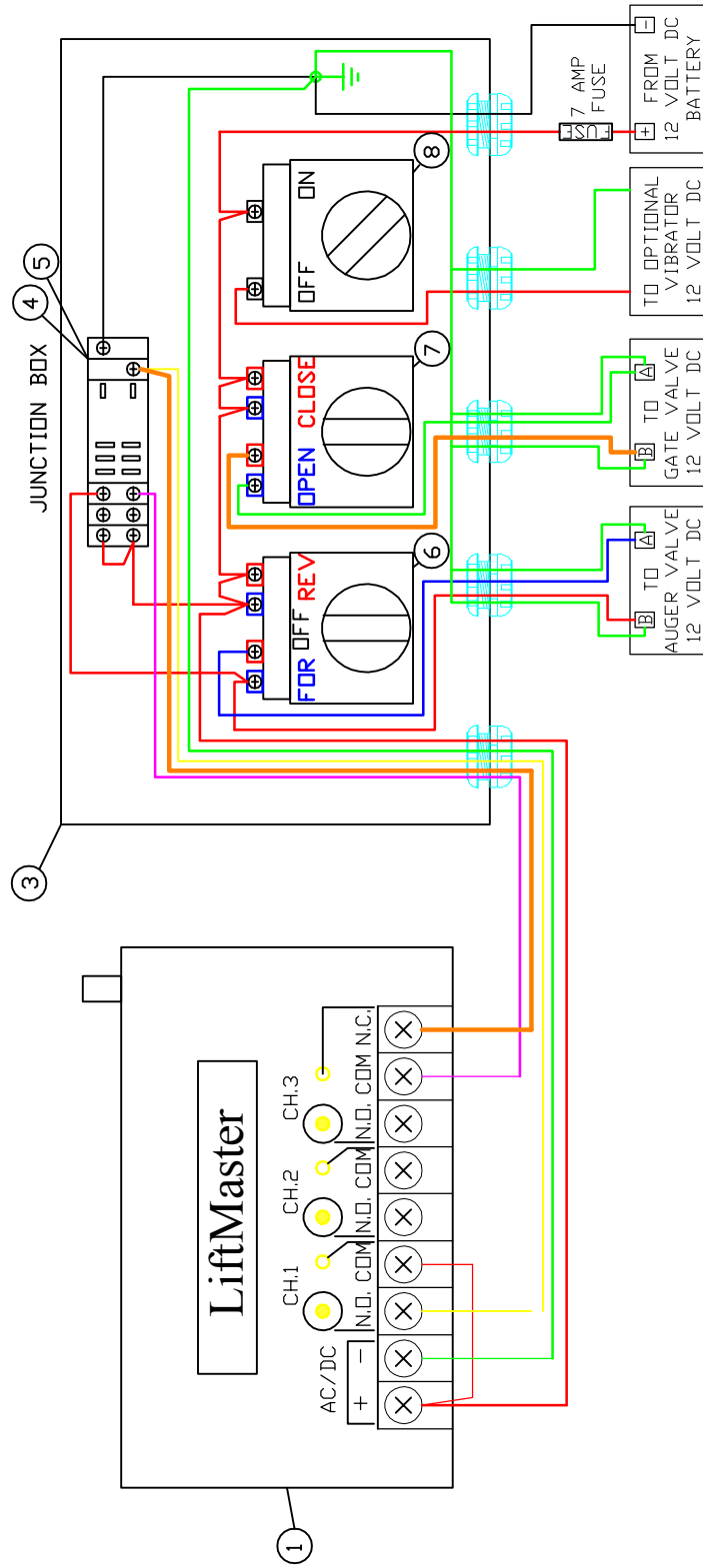

SI-LOW 206 H2 FLINTEC LOAD CELLS TO CARDINAL J BOX WIRING DIAGRAM

WIRE LEGEND

- WHITE
- RED
- YELLOW
- GREEN
- BLACK

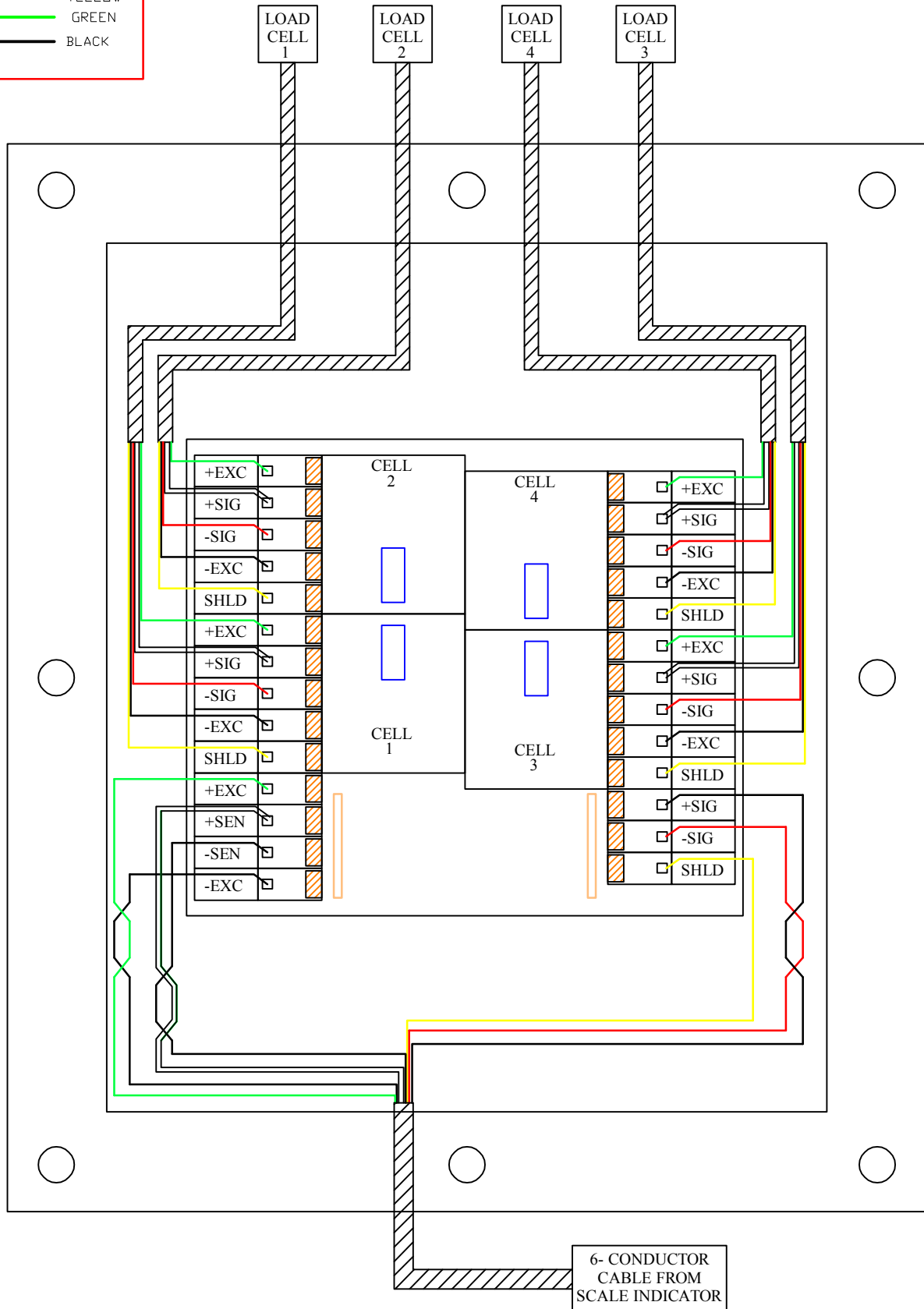



205/210
WEIGHT INDICATING INSTRUMENT
TECHNICAL and OPERATION MANUAL

8200-M024-O1 Rev E
04/02

PO BOX 151 • WEBB CITY, MO 64870
PH (417) 673-4631 • FAX (417) 673-5001
<http://www.cardinalscales.com>



Printed in USA

TABLE OF CONTENTS



STATIC ELECTRICITY PRECAUTION -----	Page 2
FCC COMPLIANCE STATEMENT -----	Page 2
SPECIFICATIONS -----	Page 3
Standard Features -----	Page 4
Additional Model 210 Features -----	Page 4
Optional Features -----	Page 4
Certifications -----	Page 4
PRECAUTIONS -----	Page 5
SITE PREPARATION REQUIREMENTS -----	Page 6
INSTALLATION -----	Page 7
MOUNTING -----	Page 7
LOAD CELL CONNECTION -----	Page 7
LOAD CELL CONNECTIONS WITH OVER 30 FEET OF CABLE -----	Page 8
LOAD CELL CABLE SHIELD WIRE CONNECTION -----	Page 8
SERIAL I/O CABLE INSTALLATION -----	Page 8
OPTICALLY ISOLATED INPUTS -----	Page 9
PRESET WEIGHT COMPARATOR/CHECKWEIGHER LOGIC LEVEL OUTPUT --	Page 9
RELAY BOARD -----	Page 10
RE-INSTALLING THE REAR PANEL -----	Page 10
MAIN PCB JUMPERS (Figure No. 6) -----	Page 11
KEYPAD FUNCTIONS - Model 205 -----	Page 12
ANNUNCIATORS - Model 205 -----	Page 14
KEYPAD FUNCTIONS - Model 210 -----	Page 15
ANNUNCIATORS - Model 210 -----	Page 19
SETUP AND CALIBRATION -----	Page 21
SETUP REVIEW -----	Page 34
CALIBRATION "C" NUMBERS -----	Page 34
ACCUMULATORS -----	Page 35
BEFORE YOU CALL SERVICE -----	Page 36
ERROR CODES -----	Page 37
CALIBRATION SEAL INSTALLATION -----	Page 38
OPTIONAL BATTERY OPERATION -----	Page 39
APPENDIX A – ANALOG OUTPUT OPTION (DAC) BOARD -----	Page 42
EUROPEAN DECLARATION OF CONFORMITY -----	Page 44
PART IDENTIFICATION -----	Page 45

SERIAL NUMBER _____
DATE OF PURCHASE _____
PURCHASED FROM _____

RETAIN THIS INFORMATION FOR FUTURE USE

PRECAUTIONS

Before using this instrument, read this manual and pay special attention to all "WARNING" symbols:

		
IMPORTANT	ELECTRICAL WARNING	STATIC SENSITIVE

STATIC ELECTRICITY PRECAUTION



CAUTION! This device contains static sensitive circuit cards and components. Improper handling of these devices or printed circuit cards can result in damage to or destruction of the component or card. Such actual and/or consequential damage IS NOT covered under warranty and is the responsibility of the device owner. Electronic components must be handled only by qualified electronic technicians who follow the guidelines listed below:



ATTENTION! ALWAYS use a properly grounded wrist strap when handling, removing or installing electronic circuit cards or components. Make certain that the wrist strap ground lead is securely attached to an adequate ground. If you are uncertain of the quality of the ground, you should consult a licensed electrician.

ALWAYS handle printed circuit card assemblies by the outermost edges. NEVER touch the components, component leads or connectors.



ALWAYS observe warning labels on static protective bags and packaging and NEVER remove the card or component from the packaging until ready for use.

ALWAYS store and transport electronic printed circuit cards and components in anti-static protective bags or packaging.

FCC COMPLIANCE STATEMENT

WARNING! This equipment generates, uses and can radiate radio frequency and if not installed and used in accordance with the instruction manual, may cause interference to radio communications. It has been tested and found to comply with the limits for a Class A computing device pursuant to Subpart J of Part 15 of FCC rules, which are designed to provide reasonable protection against such interference when operated in a commercial environment. Operation of this equipment in a residential area may cause interference in which case the user will be responsible to take whatever measures necessary to correct the interference.

You may find the booklet "How to Identify and Resolve Radio TV Interference Problems" prepared by the Federal Communications Commission helpful. It is available from the U.S. Government Printing Office, Washington, D.C. 20402. Stock No. 001-000-00315-4.

All rights reserved. Reproduction or use, without expressed written permission, of editorial or pictorial content, in any manner, is prohibited. No patent liability is assumed with respect to the use of the information contained herein. While every precaution has been taken in the preparation of this manual, the Seller assumes no responsibility for errors or omissions. Neither is any liability assumed for damages resulting from use of the information contained herein. All instructions and diagrams have been checked for accuracy and ease of application; however, success and safety in working with tools depend to a great extent upon the individual accuracy, skill and caution. For this reason the Seller is not able to guarantee the result of any procedure contained herein. Nor can they assume responsibility for any damage to property or injury to persons occasioned from the procedures. Persons engaging the procedures do so entirely at their own risk.

SPECIFICATIONS

Power Requirements:	90 to 264 VAC (50/60 Hz) at 0.4A
Battery Operation:	CAM-350 Type 12 volt 2000 mAh (2.0 Ah)
Enclosure Type, Size:	NEMA 4X/IP66: 9 3/16"W x 7 1/2"H x 3 1/8"D (233mm W x 191mm H x 79mm D) Weight: 8.2lbs - (9.6lb with battery)
Operating Environment:	Temperature: 14 to 104 °F (-10 to +40 °C) Humidity: 90% non-condensing (maximum)
Display:	6-digit, 0.6" high, 7-segment LED
Transducer Excitation:	12 VDC (Jumper selectable) 8 VDC with battery operation (jumper selectable)
Signal Input Range:	1.0 mV min. to 40 mV max. (with dead load boost)
Number of Load Cells:	8 each, 350 OHM minimum resistance
Load Cell Cable Length:	1500 feet maximum. Consult factory for other requirements 30 feet maximum without sense lines
Division Value:	1, 2, or 5 x 10, 1, 0.1, 0.01, 0.001 and 0.0001 commercial 0 to 99, non-commercial
Sensitivity:	NON-COMMERCIAL 0.15 uV/e NTEP 0.3uV/e (Class III/IIIL) CANADA 0.3uV/e (Class III/IIILD) OIML 0.7 uV/e (Class III)
Scale Divisions:	NON-COMMERCIAL 100 to 240,000 NTEP 100 to 10,000 (Class III/IIIL) CANADA 100 to 10,000 (Class III/IIILD) OIML 100 to 10,000 (Class III)
Internal Resolution:	1 part in 16,777,216
Tare Capacity:	Scale Capacity
Sample Rate:	1 to 100 samples per second, selectable
Auto Zero Range:	0.5 or 1 through 9 divisions
Weighing Units:	Tons, Pounds, Pounds-Ounces, Ounces, Metric Tons, Kilograms, Grams
Keypad:	Color coded Membrane type Model 205 - 7 keys Model 210 - 22 keys
Standard I/O:	(1) bi-directional RS232 (20mA) (1) output only RS232 (20mA)
Optional I/O:	14 bit Analog Output (0 to 10v, 4 to 20mA)

SPECIFICATIONS, Cont.

Standard Features:

- Push button tare function
- Gross, tare, net conversion
- Selectable key lockout
- Hi-Resolution mode
- Adjustable filtering
- Gross and Net accumulators
- Dual serial ports
- Remote input lines for Zero, Tare, Gross and Print (1000 feet maximum)
- Programmable print format using Visual Print or nControl (2 Visual Tickets available)
- SMA level 2 compliant serial communications
(For more information see <http://www.scalemanufacturers.org>)
- Field re-programmable via PC interconnection
- Test feature (performs display and internal tests)
- Battery operation
- Auto Shutoff and Sleep modes

Additional Model 210 Standard Features:

- Numeric keypad
- Keypad tare function
- Count feature with accumulator
- Time and Date with selectable 12 or 24 hour operation
- Checkweighing
- Three Preset Weight Comparators

Optional Features:

- Analog Output
- Battery Operation
- Special Filtering
- Column Mounting available

Certifications:

This equipment is certified to comply with the requirements for a Class III/IIIL device by the

- National Conference on Weights and Measurements (Certificate No. 01-011)
- Measurement Canada (Approval No. AM-5397)
- And for a Class III device by OIML R-76 (Certificate No. DK 0199.47).



PRECAUTIONS

Static Electricity



CAUTION! This device contains static sensitive circuit cards and components. Improper handling of these devices or printed circuit cards can result in damage to or destruction of the component or card. Such actual and/or consequential damage IS NOT covered under warranty and is the responsibility of the device owner. Electronic components must be handled only by qualified electronic technicians who follow the guidelines listed below:



ATTENTION! ALWAYS use a properly grounded wrist strap when handling, removing or installing electronic circuit cards or components. Make certain that the wrist strap ground lead is securely attached to an adequate ground. If you are uncertain of the quality of the ground, you should consult a licensed electrician.

ALWAYS handle printed circuit card assemblies by the outermost edges. NEVER touch the components, component leads or connectors.



ALWAYS observe warning labels on static protective bags and packaging and NEVER remove the card or component from the packaging until ready for use.

ALWAYS store and transport electronic printed circuit cards and components in anti-static protective bags or packaging.

Environmental

The 205/210 indicators meet or exceeds all certification requirements within a temperature range of 14 to 104 °F (-10 to +40 °C).

In order to keep cooling requirements to a minimum, the indicator should be placed out of direct sunlight and to provide adequate air circulation, keep the area around the indicator clear.

Make certain the instrument is not directly in front of a heating or cooling vent. Such a location will subject the indicator to sudden temperature changes, which may result in unstable weight readings.

Insure that the indicator has good, clean AC power and is properly grounded.

In areas subject to lightning strikes, additional protection to minimize lightning damage, such as surge suppressors, should be installed.

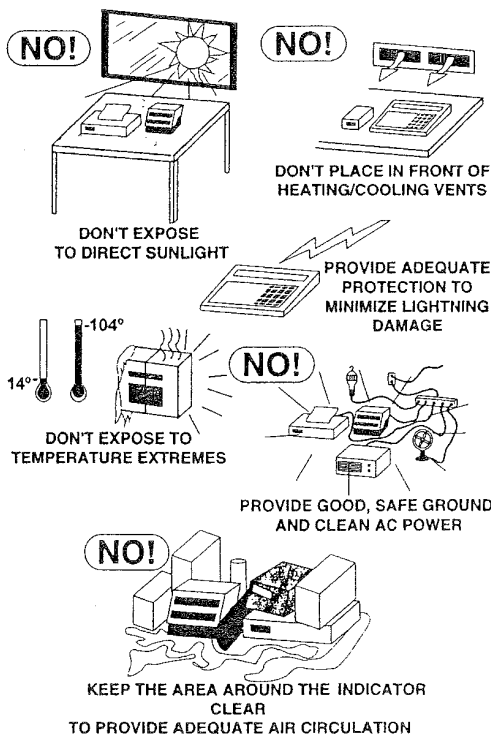

PRECAUTIONS, Cont.

Care and Cleaning

1. **DO NOT** submerge indicator in water, pour or spray water directly on instrument.
2. **DO NOT** use acetone, thinner or other volatile solvents for cleaning.
3. **DO NOT** expose equipment to temperature extremes.
4. **DO NOT** place equipment in front of heating/cooling vents.
5. **DO** clean the indicator with a damp soft cloth and mild non-abrasive detergent.
6. **DO** remove power before cleaning with a damp cloth.

SITE PREPARATION REQUIREMENTS

The Cardinal 205/210 indicators are precision weight-measuring instruments. As with any precision instrument, they require an acceptable environment to operate at peak performance and reliability. This section is provided to assist you in obtaining such an environment.

Electrical Power

The 205/210 indicators have been designed to operate from 90 to 264 VAC at 50/60 Hz. Note that a special order is not required for operation at 230 VAC.



CAUTION! - To avoid electrical hazard and possible damage to the indicator, **DO NOT**, under any circumstance, cut, remove, alter, or in any way bypass the power cord grounding prong.

On models requiring 230 VAC power, **it is the responsibility of the customer** to have a qualified electrician install the proper power cord plug which conforms to national electrical codes and local codes and ordinances.

The power outlet for the indicator should be on a separate circuit from the distribution panel. This circuit should be dedicated to the exclusive use of the indicator. The wiring should conform to national and local electrical codes and ordinances and should be approved by the local inspector to assure compliance.

To prevent electrical noise interference, make certain all other wall outlets for use with air conditioning and heating equipment, lighting or other equipment with heavily inductive loads, such as welders, motors and solenoids are on circuits separate from the indicator. Many of these disturbances originate within the building itself and can seriously affect the operation of the instrument. These sources of disturbances must be identified and steps must be taken to prevent possible adverse effects on the instrument. Examples of available alternatives include isolation transformers, power regulators, uninterruptible power supplies, or simple line filters.



CAUTION! When in parallel runs, locate Load Cell cables a minimum of 24" away from all AC wiring.

INSTALLATION

Before beginning installation of your 205/210 Weight Indicating Instrument, make certain that the instrument has been received in good condition. Carefully remove the instrument from the shipping carton and inspect it for any evidence of damage (such as exterior dents or scratches) that may have taken place during shipment. Keep the carton and packing material for return shipment if it should become necessary. It is the responsibility of the purchaser to file all claims for any damages or loss incurred during transit.

MOUNTING

NOTE! Should your 205/210 indicator come already installed on a scale, the following information describing the installation of the instrument does not apply.

The Model 205/210 Indicator is housed in a NEMA 4X/IP66 stainless steel wall or desk-mount enclosure. The 205/210 gimbal may be mounted on a desktop or other smooth, flat, horizontal surface or may be mounted on a wall. Refer to Figure No. 1 for a layout of wall-mounting bolts.

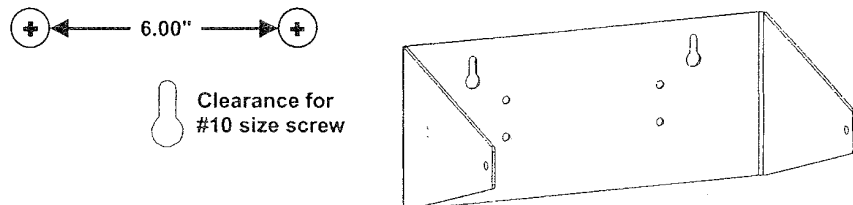



Figure No. 1

If wall mounted, make certain the mounting surface is strong enough to support the instrument. The mounting location should be where the display is easily viewed while being close enough to provide the operator easy access to the keypad. Carefully lay out the mounting hole locations, then drill and install the anchor bolts. Attach the gimbal to the wall and securely tighten the retaining bolts.

LOAD CELL CONNECTION

 **CAUTION!** Disconnect any external load cell power supply before connecting load cells to the instrument. Failure to do so will result in permanent damage to the instrument.

1. Remove the 12 acorn nuts securing the back panel to the main housing, then loosen the bottom-left cable gland connector for the load cell. This gland connector is located on the rear panel of the enclosure. Refer to Figure No. 2 for illustration of the connector layout.
2. Slip the single cable from the load cell or load cell junction box through the gland connector and into the enclosure.
3. Remove 2" of the outer insulation jacket then remove 1/4" of insulation from each of the 4 wires and shield without sense leads or 6 wires and shield with sense leads (refer to figure No. 3).

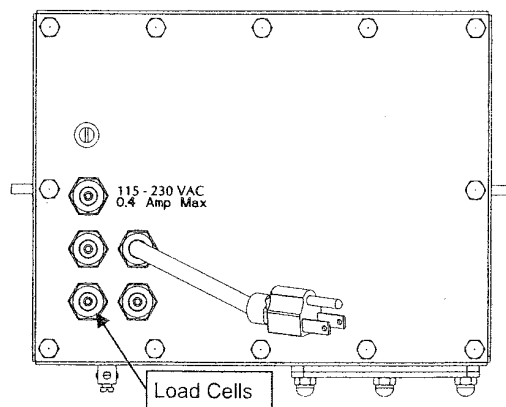

Figure No. 2

INSTALLATION, Cont.

3. Connect each of the wires to terminal block P1 referring to the labels on the circuit board for terminal connections. Refer to Figure No. 6 for terminal block location.

4. To terminate a wire, first press down on the release bar for the terminal, insert the wire into the terminal opening then allow the release bar to return to its original position, locking the wire in place. Repeat the procedure until all of the wires are in place.

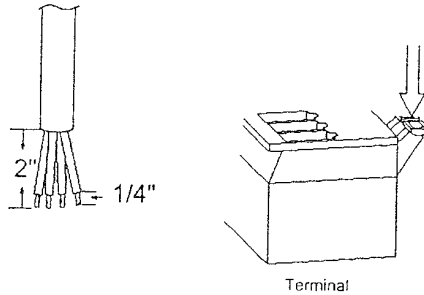

Figure No. 3

5. Route the load cell cable through the two cable clips provided on the upper and left sides of the enclosure interior.

NOTE! If the sense leads are NOT used, you must install plug-in jumpers at J4 and J5 adjacent to the terminal block. These jumpers attach the sense leads to the excitation leads. If sense leads ARE used (as in motor truck scales), these plug-in jumpers should be positioned on one plug-in pin only or removed and stored for later use.

LOAD CELL CONNECTOR P1

PIN NO.	Function	PIN NO.	Function
1	+ EXCITATION	5	- SIGNAL
2	+ SENSE	6	- SENSE
3	+ SIGNAL	7	- EXCITATION

LOAD CELL CONNECTIONS WITH OVER 30 FEET OF CABLE

For installations with over 30 feet of cable between the indicator and the load cells, sense wires should be used. The sense wires must be connected between the +SENS, -SENS terminals on the indicator and the +EXCITATION, -EXCITATION wires of the load cells or the +SENS, -SENS terminals of the load cell trim board or the section seal trim board. For the indicator to use the sense wires, the +SENS jumper J4 and the -SENS jumper J5 must be open (see Figure No. 6).

Load Cell Cable Shield Wire Connection

The load cell cable shield wire should be connected to the threaded stud inside the indicator. This stud is located on the top inside of the indicator near the load cell connector P1. See Figure No.4.

The shield wire should be wrapped around the stud between the 2 flat washers and secured using the hex nut.

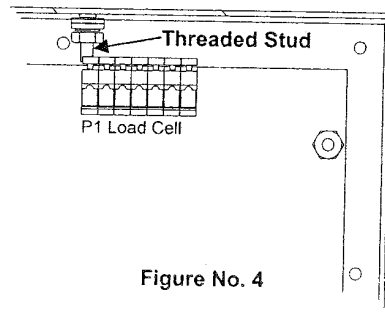

Figure No. 4

SERIAL I/O CABLE INSTALLATION

The 205/210 indicators may be connected to a printer to record weight and associated data or it may be connected to a remote display or even to a computer for transmission of weight data. The weight data may be transmitted on demand (pressing the **PRINT** key or on receipt of a command from the computer). Refer to the Setup, SIO Serial I/O section of this manual.

1. Loosen the cable gland connector(s) for the serial cable. The gland connector(s) for the serial data are located on the rear panel of the enclosure. Refer to Figure No. 2 for an illustration of the gland connector layout.
2. Slip the serial cable through the gland connector and into the enclosure.
3. Remove 2" of the outer insulation jacket then remove 1/4" of insulation from each of the wires (refer to Figure No. 3).

INSTALLATION, Cont.

SERIAL I/O CABLE INSTALLATION, Cont.

4. Connect each of the wires to the Serial Data terminal block (P11) referring to Figure No. 6 for terminal block locations.
5. To terminate, first press down on the release bar for the terminal, insert the wire into the opening then allow the release bar to return to its original position, locking the wire in place. Repeat the procedure until all of the wires are in place.

BI-DIRECTIONAL SERIAL INTERFACE

<u>PIN NO.</u>	<u>Function</u>
1	TXD 1 - RS232
2	RXD 1 - RS232
3	TXD 1 - 20 mA Active
4	GROUND

SERIAL OUTPUT

<u>PIN NO.</u>	<u>Function</u>
5	TXD 2 - RS232
6	TXD 2 - 20 mA Active
7	GROUND

OPTICALLY ISOLATED INPUTS

Included with the I/O are 4 programmable inputs that may be used to remotely (up to 100 feet) initiate various functions within the indicator. These inputs are accessed via a terminal block (P9) on the back of the PC board (see Figure No. 6). The 4 inputs are defined as follows:

<u>PIN NO.</u>	<u>Function</u>
1	Gross
2	Print
3	Zero
4	Tare
5	Common

Remember that the input must be connected to Gnd to initiate the function.

PRESET WEIGHT COMPARATOR

CHECKWEIGHER LOGIC LEVEL OUTPUT

(Optional, Model 210 Only)

If you so choose, you may use the logic level outputs from your Model 210 indicator's preset weight comparators or checkweigher to control peripheral devices used to manage the flow of material or signal when the weight is within preset limits. Note that these outputs are at logic level and cannot drive external devices directly. Solid state relays can be used to accept the logic level output from the 210 and in turn, drive the external device. Maximum output is 5VDC @ 25mA.

To connect the control cable to the preset weight comparator/checkweigher logic level output connector P10, first loosen the gland connector located on the back of the 210 on the right side. Refer to Figure No. 6 for the exact location of this connector. Slip the cable through this connector and into the enclosure. Remove 2 inches of the cable insulating jacket then 1/4 inch of insulation from each of the internal wires (refer to Figure No. 3). Make the proper terminations on terminal block P10. To terminate a wire, first press down on the terminal block release bar, insert the wire into the terminal and remove pressure from the release bar locking the wire in place.

INSTALLATION, Cont.

RELAY BOARD - (Optional, Model 210 Only)

The relay board (Cardinal p/n 8539-C062-0A) is mounted in the RB4-F external junction box for use with the 210 Indicator. Connect the devices to be controlled as shown in Figure No. 5.

The relays MUST be configured to be on (closed) or off (open) at weights under the preset weight then switch at the preset weight from on-to-off or off-to-on by setting the under weight condition to on or off during setup and calibration or setup review. Refer to the Setup and Calibration, "d out" (Digital Output) section of this manual for more information.

EXAMPLE: d out= 1,1

PWC1 relay is on (closed) for weights under the preset weight and off (open) for weights equal to or over the preset weight.

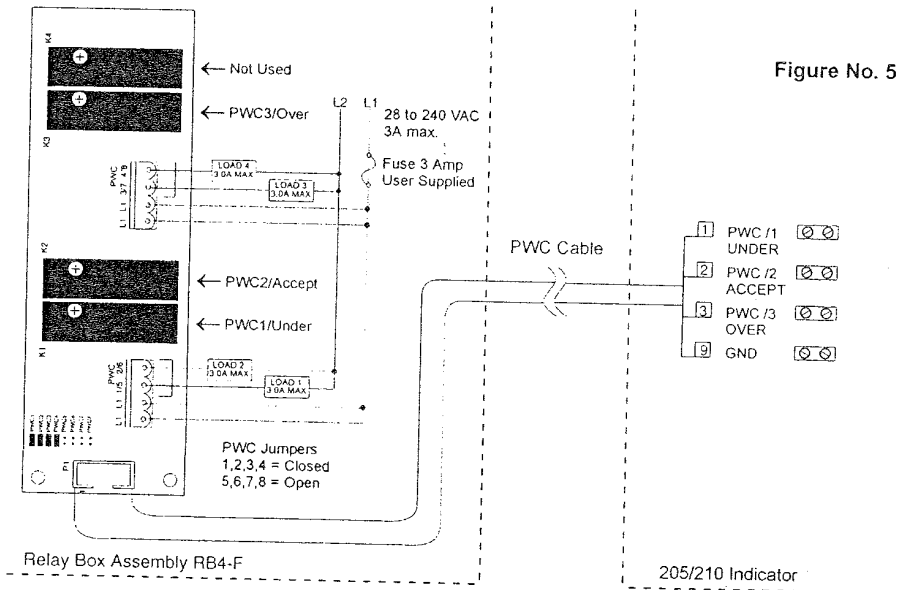

NOTE! All relays are the normally-open type that will open when power to indicator is lost.

RE-INSTALLING THE REAR PANEL

After all terminations have been made, remove the excess cable from the instrument enclosure and securely tighten each of the cable gland connectors. Do not over-tighten these connectors but make certain they are snug. **DO NOT USE TOOLS!** Finger tighten only! Insure any unused gland connectors are plugged.

Make certain no cables or wires are exposed between the main housing and rear panel then place the rear panel onto the main housing. Secure with the 12 acorn nuts removed earlier.

NOTE! Follow a diagonal pattern when tightening the acorn nuts.

INSTALLATION, Cont.

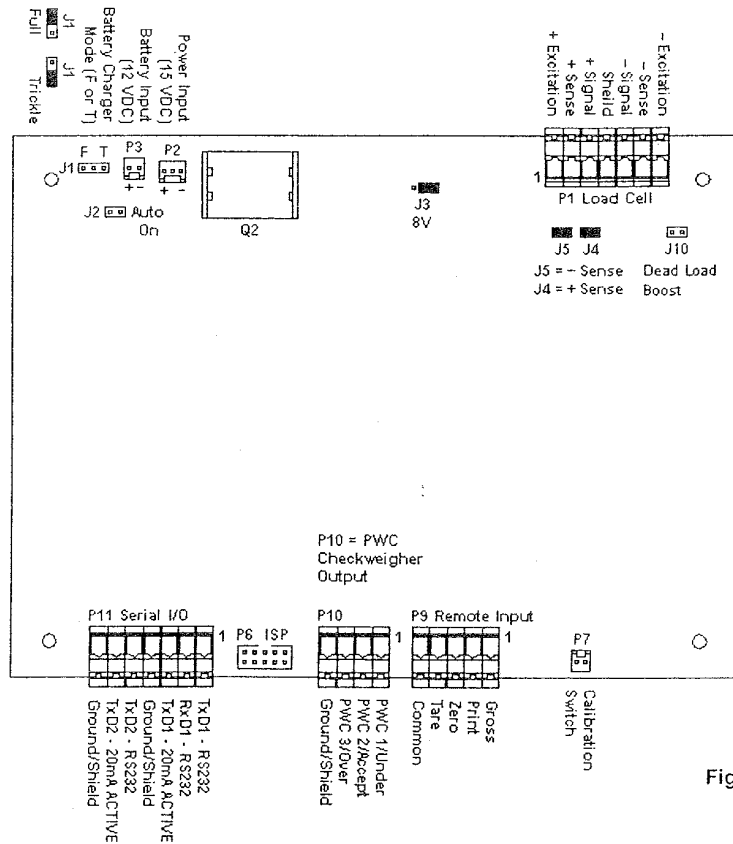

Figure No. 6

MAIN PCB JUMPERS

J1 - BATTERY CHARGE MODE

Place jumper J1 in the Full position when operating the indicator totally from battery power and only recharging the battery pack when it is low. Place jumper J1 in the Trickle position when operating the indicator from commercial power and using the battery pack to supply power only in the event of a power loss.

J2 - AUTO-ON JUMPER

The AUTO-ON jumper J2, when connected, will cause the indicator to power on automatically whenever power is applied to the power input connector. If power is lost momentarily and then reapplied, the indicator will turn on without pressing the ON key.

J3 - 8V EXCITATION JUMPER

The 8V EXCITATION jumper J3, when connected, sets the load cell excitation voltage to 8V for operation with the 12 VDC battery. To operate from the 12 VDC battery, the load cell excitation voltage MUST be set to 8 VDC (J3 closed). Battery operation with the load cell excitation voltage set to 12V will result in an unstable weight display.

J4 AND J5 - SENSE JUMPERS

If the sense leads are NOT used, you must install plug-in jumpers at J4 and J5 adjacent to the terminal block. These jumpers attach the sense leads to the excitation leads. If sense leads ARE used (as in motor truck scales), these plug-in jumpers should be positioned on one plug-in pin only or removed and stored for later use.

J10 - DEAD LOAD BOOST JUMPER

For very low dead loads (less than 10% of the combined load cell capacity) connect the dead load boost jumper J10 on the printed circuit board.

KEYPAD FUNCTIONS - MODEL 205

The Model 205 is equipped with a 7-key keypad. The keypad is used to enter commands and data into the instrument. This section describes each key along with its normal function. It is helpful to refer to the actual instrument while reading this section.



The membrane keypad is not to be operated with pointed objects (pencils, pens, fingernails, etc). Damage to keypad resulting from this practice is NOT covered under warranty.

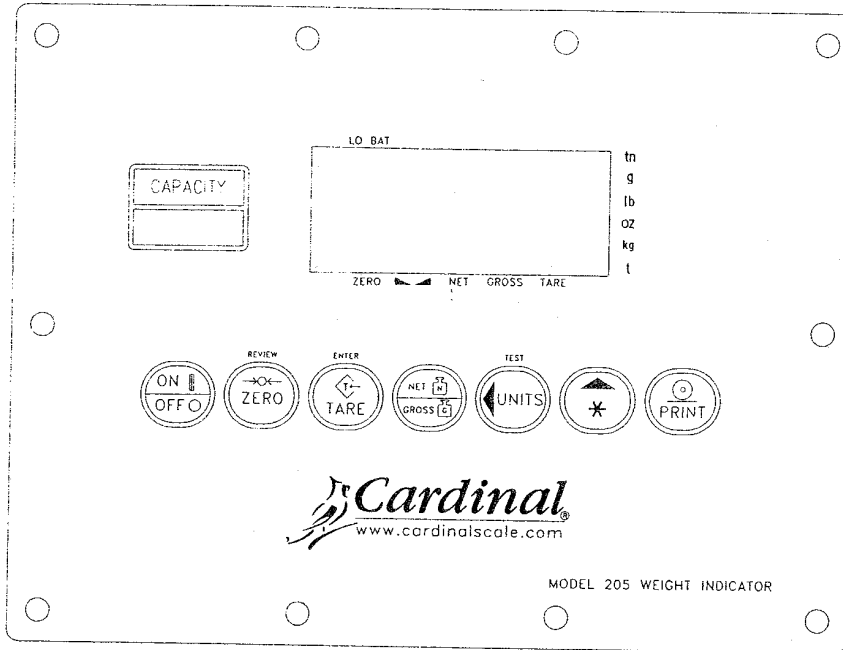

Figure No. 7

ON/OFF KEY

This key performs two functions. Pressing it when the indicator is off will apply power to the instrument. If the indicator is already on, pressing this key will turn the indicator off.

ZERO KEY

Pressing this key will cause an immediate zeroing of the weight display up to the selected limit of 4% or 100% of the scale's capacity. This selection is made during the setup and calibration of the instrument. Note that the indicator will not respond to this command unless the weight display is stable.

TARE KEY

Pressing the **TARE** key alone will cause the current gross weight to be stored as the new tare weight and cause the weight display to change to the net weight display mode (Net annunciator will turn on).

NET/GROSS KEY

This key is used to toggle between Net and Gross weight modes. The selected mode is indicated by turning on the appropriate annunciator on the display. Note that if no valid tare weight has been entered, pressing this key will cause a momentary "notArE" display error and the indicator will remain in the Gross weight mode.

KEYPAD FUNCTIONS - MODEL 205, Cont.

UNITS/LEFT ARROW KEY

This key performs two functions. In normal operation, this key is used to select the units in which the weight is to be displayed. The available units of measure ("unit1" and "unit2") are selected in setup. The available units include tons, pounds only, pound-ounces, ounces only, tonnes (metric tons), kilograms, and grams. Note that not all combinations are supported. During setup, this key is used to advance the cursor left to the next position when inputting setup parameters.

PRINT KEY

Pressing this key will add the displayed gross or net weight to the associated accumulator and initiate the transmission of weight and other data depending on the Print Tab Settings (see example) via the selected printer output port (see Port= under Print menu) unless the continuous data feature of this port was enabled during setup and calibration. Note that the indicator will not respond to this command unless the weight display is stable. If displaying gross weight, the only weight printed is gross weight. If displaying net weight, the gross, tare, and net weights are printed.

The 205 includes support for visual tickets. Visual tickets are designed by the PC based programs Visual Print or n Control, then downloaded to the indicator. The 205 allows two programmable formats in addition to the standard print tab settings format.

Print formats are selected by using the **ASTERISK** and **PRINT** keys in combination (refer to the next section for details). **NOTE!** When the **PRINT** key is pressed the indicator looks for the selected format. If no visual ticket is found it reverts to the print tab settings.

```
#2
10:19 23/08/2000
100.00 lb G
20.00 lb T
80.00 lb N
0.00 lb GROSS ACCUM
272.00 lb NET ACCUM
```

TICKET EXAMPLE

ASTERISK/UP ARROW KEY

This key is used for several functions. During setup, when a setup parameter (not a parameter value) is displayed, pressing this key will "backup" to the previous prompt. Also during setup, when a parameter value is displayed, pressing this key will "toggle" between the different available values for the setup parameter. In normal operation, this key is used in conjunction with the other keys on the keypad to access additional indicator features. These features and their associated key combinations are as follows:

ASTERISK, ZERO KEY

This combination will enter the Review mode of Setup and Calibration. Refer to Setup Review section of this manual for details.

ASTERISK, TARE KEY

This combination will display the current tare weight for three (3) seconds.

ASTERISK, NET/GROSS KEY

This combination will display the Net accumulator.

ASTERISK, NET/GROSS KEY, PRINT KEY

This combination will print the Net accumulator.

ASTERISK, NET/GROSS KEY, ZERO KEY

This combination will zero (clear) the Net accumulator.

ASTERISK, NET/GROSS KEY, NET/GROSS KEY

This combination will display the Gross accumulator.

ASTERISK, NET/GROSS KEY, NET/GROSS KEY, PRINT KEY

This combination will print the Gross accumulator.

ASTERISK, NET/GROSS KEY, NET/GROSS KEY, ZERO KEY

This combination will zero (clear) the Gross accumulator.

KEYPAD FUNCTIONS - MODEL 205, Cont.

ASTERISK, UNITS KEY

This combination will enter the Test mode. The Test mode is used to conduct a test of all display elements. The test consists of 5 cycles, each lasting about one second:

1. All horizontal segments will turn on (no annunciators).
2. All vertical segments and decimal points will turn on (no annunciators).
3. All annunciators will turn on.
4. All display elements off.
5. The model number (205) and the software version X.X.
6. The calibration numbers (C1 to C4).

ASTERISK, PRINT KEY

This combination is used to *change* the selected print ticket format. Pressing the **ASTERISK** then the **PRINT** key will display a prompt "Prt=". Press the **ENTER** key to show the current value. If the setting displayed is acceptable, press the **ENTER** key again to save it. Otherwise, press the **ASTERISK/UP ARROW** key to "toggle" between the different available values, then press the **ENTER** key to save it. Allowable values are:

0 = print tab settings 1 = visual ticket format 1 2 = visual ticket format 2

NOTE! When a print format is selected, it will remain active until changed by the operator.

ANNUNCIATORS – MODEL 205

Annunciators are turned on to indicate that the display is in the mode corresponding to the annunciator label or that the status indicated by the label is active. The annunciators flash on and off to indicate that the 205 is waiting for an input from the keypad for the mode indicated by the flashing annunciator. Refer to Figure No. 7 for location of the annunciators.

ZERO

The ZERO annunciator indicates that the weight is within +/- 1/4 division of the center of zero.

STABLE

The STABLE annunciator is identified with two small triangle shapes and is turned on when the weight display is stable. This means that the change in successive weight samples is less than the motion limits selected during setup and calibration of the instrument.

NET

The NET annunciator is turned on to show that the displayed weight is the net weight (gross weight less tare weight).

GROSS

The GROSS annunciator indicates that the displayed weight is the gross weight.

LO BAT

The LO BAT annunciator is used with the battery operation and will turn ON to indicate that the internal battery requires charging. If continued use further drains the battery, no change in operation will occur until just before the battery voltage drops to a level where operation is affected. At this level, the indicator will automatically turn itself off. Note that when the indicator is charging the battery, the LO BAT annunciator will NOT be on.

T

The T (tons) annunciator is located to the right of the weight display and is turned on to show that the displayed weight units is tons.

g

The g (grams) annunciator is located to the right of the weight display and is used to indicate that the displayed units of weight measurement is grams.

ANNUNCIATORS - MODEL 205, Cont.

lb

The **lb** (pounds) annunciator is located to the left of the weight display and is turned on to indicate that the displayed weight units is pounds.

oz

The **oz** (ounces) annunciator is located to the right of the weight display and is turned on to show that the displayed weight units is ounces.

kg

The **kg** (kilograms) annunciator is located to the left of the weight display and indicates that the displayed units of weight measurement is kilograms.

t

The **t** (tonnes, metric tons) annunciator is located to the right of the weight display and is used to indicate that the displayed units of weight measurement is tonnes (metric tons).

KEYPAD FUNCTIONS - MODEL 210

The Model 210 is equipped with a 22-key keypad. The keypad is used to enter commands and data into the instrument. This section describes each key along with its normal function. It is helpful to refer to the actual instrument while reading this section.



The membrane keypad is not to be operated with pointed objects (pencils, pens, fingernails, etc). Damage to keypad resulting from this practice is NOT covered under warranty.

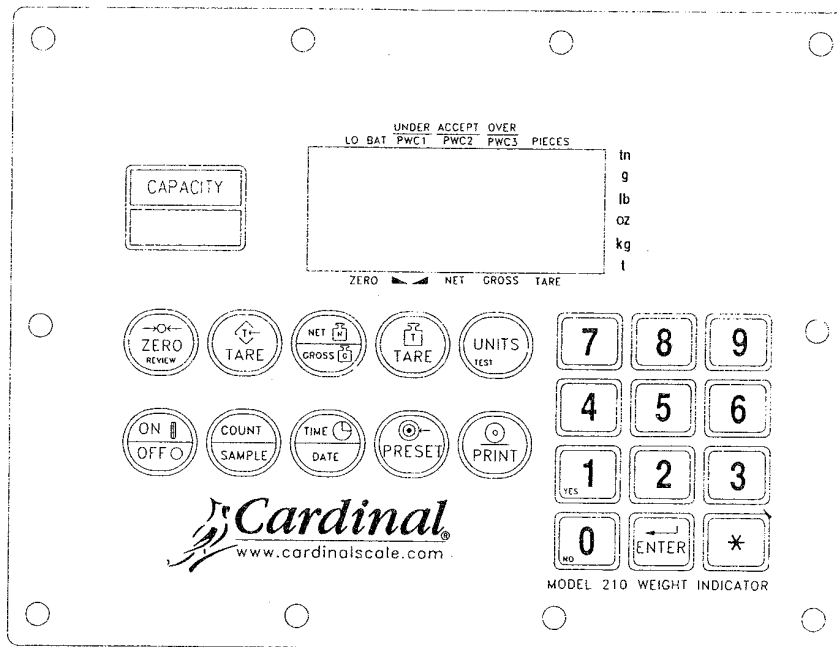

Figure No. 8

ON/OFF KEY

This key performs two functions. Pressing it when the indicator is off will apply power to the instrument. If the indicator is already on, pressing this key will turn the indicator off.

KEYPAD FUNCTIONS - MODEL 210, Cont.

COUNT/SAMPLE KEY

This key performs two functions. The first time it is pressed, the indicator will count (unless piece weight is 0). The second time it is pressed (or if pcwt=0 on the first press) will show the prompt "ADD=5" on the display. Continued pressing of the **COUNT/SAMPLE** key will toggle between the ADD=5, 10, 25, 50, 75 prompts to select a sample size. When desired sample size is displayed, press the **ENTER** key **OR** with "ADD=XX" (5, 10 etc.) displayed, using the numeric keypad, key in any desired sample value, then press the **ENTER** key. Press the **ASTERISK** key to abort the input operation. To exit the count function and display weight, press the **NET/GROSS** key.

TIME/DATE KEY

This key is used to enter the clock mode to program the time, date and consecutive number.

Pressing the **TIME/DATE** key will enter the clock mode with the 210 displaying HoUr=.

12-Hour Format Selected In Setup (td=12)

1. With the display showing HoUr=, press the **ENTER** key.
2. If the time displayed is correct, press the **ENTER** key and proceed to step 4.
3. If the displayed time is incorrect, use the numeric keys to enter the correct time and press the **ENTER** key.
4. The display will change to A=. Press the **ENTER** key.
5. The display will show YES.
 - If the time is before noon (12:00 PM), press the **ENTER** key.
 - If the time is after noon (12:00 PM), press the **0/NO** key, then press the **ENTER** key.
6. The display will show dAtE=. Press the **ENTER** key.
7. If the date displayed is correct, press the **ENTER** key to proceed to the consecutive number prompt, Cn.C .n=.
8. If the date displayed is incorrect, use the numeric keys to enter the correct date and press the **ENTER** key to proceed to the consecutive number prompt. Remember to enter the date in the same format (month-day-year or day-month-year) as selected by the USA setup parameter. Note that with the USA=YES setting, the date format is month-day-year.

24-Hour Format Selected In Setup (td=24)

1. With the display showing HoUr=, press the **ENTER** key.
2. If the time displayed is correct, press the **ENTER** key and proceed to step 4.
3. If the displayed time is incorrect, use the numeric keys to enter the correct time and press the **ENTER** key. Note that with the 24-hour format selected, entering all times after noon (12:00 PM), you must add 12 to the time, i.e. 3 PM would be 1500.
4. The display will show dAtE=. Press the **ENTER** key.
5. If the date displayed is correct, press the **ENTER** key to proceed to the consecutive number prompt, Cn.C .n=.
6. If the date displayed is incorrect, use the numeric keys to enter the correct date and press the **ENTER** key to proceed to the consecutive number prompt. Remember to enter the date in the same format (month-day-year or day-month-year) as selected by the USA setup parameter. Note that with the USA=YES setting, the date format is month-day-year.

Consecutive Number

If the consecutive number displayed is correct, press the **ENTER** key to resume normal operation. If the consecutive number displayed is incorrect, use the numeric keys to enter the correct consecutive number (up to 6 digits) and press the **ENTER** key to resume normal operation.

PRESET KEY

This key is used to enter the weight values for the three preset weight comparators or for the checkweigher feature depending on which feature was selected (setup parameter "d out") during setup and calibration.

KEYPAD FUNCTIONS - MODEL 210, Cont.

Preset Weight Comparator

If the Preset Weight Comparator feature was selected, the PWC1 annunciator will flash and the display will show the currently stored value for the number 1 preset weight comparator. If the value displayed is acceptable, press the **ENTER** key, otherwise, use the numeric keys to enter the new preset value and press the **ENTER** key. The PWC2 annunciator will now flash and the display will show the currently stored value for the number 2 preset weight comparator. As before, if the value displayed is acceptable, press the **ENTER** key, otherwise, use the numeric keys to enter the new value and press the **ENTER** key. The PWC3 annunciator will now flash and the display will show the currently stored value for the number 3 preset weight comparator. Again, if the value displayed is acceptable, press the **ENTER** key, otherwise, use the numeric keys to enter the new value and press the **ENTER** key.

Checkweigher

If the Checkweigher feature was selected and the **PRESET** key pressed, the **ACCEPT** and **UNDER** annunciators will flash and the preset value for the minimum acceptable weight will be displayed. Press the **ENTER** key if the displayed value is correct or use the numeric keys and enter the new value and press the **ENTER** key. The **ACCEPT** and **OVER** annunciators will now flash and the display will show the minimum value of weight over the accepted range. As before, if the value shown is correct, press the **ENTER** key. If the value is incorrect, enter the new value and press the **ENTER** key to save it. Note that this value must be greater than the accept value. Remember that both the preset weight comparators and checkweigher functions operate on the absolute value of the weight ignoring the polarity. After the second preset value is entered, the 210 will return to normal operation.

PRINT KEY

Pressing this key will add the displayed gross or net weight or piece count to the associated accumulator and initiate the transmission of weight and other data selected during setup of the Print menu items via the selected printer output port (see Port= under Print menu) unless the continuous data feature of this port was enabled during setup and calibration.

Note that the indicator will not respond to the Print command unless the weight display is stable. If displaying gross weight, the only weight printed is gross weight. If displaying net weight, the gross, tare, and net weights are printed.

The 210 includes support for visual tickets. Visual tickets are designed by the PC based programs Visual Print or n Control, then downloaded to the indicator. The 210 allows two programmable formats in addition to the standard print tab settings format.

Print formats are selected by using the **ASTERISK** and **PRINT** keys in combination (refer to the next section for details). **NOTE!** When the **PRINT** key is pressed the indicator looks for the selected format. If no visual ticket is found it reverts to the print tab settings.

```
#2
10:19 23/08/2000
100.00 lb G
20.00 lb T
80.00 lb N
0.00 lb GROSS ACCUM
272.00 lb NET ACCUM
```

TICKET EXAMPLE

ZERO/REVIEW KEY

This key performs two functions. In normal operation, pressing this key will cause an immediate zeroing of the weight display up to the selected limit of 4% or 100% of the scale's capacity. Note that this selection is made during the setup and calibration of the instrument. Pressing this key after the **ASTERISK** key will enter the Review mode of Setup and Calibration. Refer to description of **ASTERISK** key and the Setup Review section of this manual for details.

KEYPAD FUNCTIONS - MODEL 210, Cont.

TARE KEY (with diamond "T" symbol)

This key is a dual function key. Pressing the **TARE** key alone (Pushbutton Tare mode) will cause the current gross weight to be stored as the new tare weight and cause the weight display to change to the net weight display mode (Net annunciator will turn on). Pressing this key after entering a numeric value (Keypad Tare) will cause the value entered to be accepted as the new tare weight.

NOTE: Tare weights equal to or greater than scale capacity cannot be entered. In addition, the keypad tare weight division value must be the same as the scale division value. For example, a unit with .005 lb as the division value will display **-Error** if you attempt to enter 1.003 for the tare weight.

NET/GROSS KEY

This key is used to toggle between Net and Gross weight modes. The selected mode is indicated by turning on the appropriate annunciator on the display. Note that if no valid tare weight has been entered, pressing this key will cause a momentary "notArE" display error and the indicator will remain in the Gross weight mode.

TARE KEY (with weight "T" symbol)

Pressing this key will display the current tare weight for three seconds.

UNITS/TEST KEY

This key performs two functions. In normal operation, this key is used to select the units in which the weight is to be displayed. The available units of measure ("unit1" and "unit2") are enabled or disabled in setup. The available units include tons, pounds only, pound-ounces, ounces only, tonnes (metric tons), kilograms, and grams. Note that not all combinations are supported. Pressing this key after the **ASTERISK** key will enter the Test mode. The Test mode is used to conduct a test of all display elements. Refer to description of **ASTERISK** key for details.

0 THROUGH 9 KEYS

These keys are used to enter numeric data during the setup and calibration as well as during normal operation of the instrument. **NOTE:** The 1 and 0 keys have dual functions. They are used to enter numeric data during setup and calibration as well as during normal operations and are also used to answer yes (1 = YES) or no (0 = NO) to various prompts.

ENTER KEY

The **ENTER** key serves two purposes. First, when reviewing setup parameters, pressing the **ENTER** key will display the current setting of the parameter. Second, the **ENTER** key is used to signal completion of the entry of data and causes the indicator to process the data entered.

ASTERISK KEY

This key is used for several functions. During Setup, when a setup parameter (not a parameter value) is displayed, pressing this key will "backup" to the previous prompt. In normal operation, this key is used in conjunction with the other keys on the keypad to access additional indicator features. These features and their associated key combinations are as follows:

ASTERISK, ZERO/REVIEW KEY

This combination will enter the Review mode of Setup and Calibration. Refer to Setup Review section of this manual for details.

ASTERISK, NET/GROSS KEY

This combination will display the Net accumulator.

ASTERISK, NET/GROSS KEY, PRINT KEY

This combination will print the Net accumulator.

ASTERISK, NET/GROSS KEY, ZERO KEY

This combination will zero (clear) the Net accumulator.

KEYPAD FUNCTIONS - MODEL 210, Cont.

ASTERISK, NET/GROSS KEY, NET/GROSS KEY

This combination will display the Gross accumulator.

ASTERISK, NET/GROSS KEY, NET/GROSS KEY, PRINT KEY

This combination will print the Gross accumulator.

ASTERISK, NET/GROSS KEY, NET/GROSS KEY, ZERO KEY

This combination will zero (clear) the Gross accumulator.

ASTERISK, UNITS KEY

This combination will enter the Test mode. The Test mode is used to conduct a test of all display elements. The test consists of five (5) cycles, each lasting about one (1) second:

1. All horizontal segments will turn on (no annunciators).
2. All vertical segments and decimal points will turn on (no annunciators).
3. All annunciators will turn on.
4. All display elements off.
5. The model number (210) and the software version X.X.
6. The calibration numbers (C1 to C4).

ASTERISK, PRINT KEY

This combination is used to *change* the selected print ticket format. Pressing the **ASTERISK** then the **PRINT** key will display a prompt "Prt=". Press the **ENTER** key to show the current value. If the setting displayed is acceptable, press the **ENTER** key again to save it. Otherwise, using the numeric keys enter the new setting, then press the **ENTER** key to save it. Allowable values are:

0 = print tab settings 1 = visual ticket format 1 2 = visual ticket format 2

In addition to using the **ASTERISK, PRINT** key combination to change the print ticket format, the operator (just prior to printing the ticket) can change the print ticket format at the end of the weighing operation. This is accomplished by performing the normal weighing operation, then pressing the desired format number (0, 1 or 2), followed by pressing the **PRINT** key.

NOTE! When a print format is selected (by either method), it will remain active until changed by the operator.

ANNUNCIATORS - MODEL 210

Annunciators are turned on to indicate that the display is in the mode corresponding to the annunciator label or that the status indicated by the label is active. The annunciators flash on and off to indicate that the 210 is waiting for an input from the keypad for the mode indicated by the flashing annunciator. Refer to Figure No. 8 for location of the annunciators.

ZERO

The ZERO annunciator is turned on to indicate that the weight is within +/- 1/4 division of the center of zero.

STABLE

The STABLE annunciator is identified with two (2) small triangle shapes and is turned on when the weight display is stable. This means that the change in successive weight samples is less than the motion limits selected during setup and calibration of the instrument.

NET

The NET annunciator is turned on to show that the displayed weight is the net weight (gross weight less tare weight).

GROSS

The GROSS annunciator is turned on to indicate that the displayed weight is the gross weight.

ANNUNCIATORS - MODEL 210

TARE

The TARE annunciator is turned on to show that the displayed weight is the tare weight.

LO BAT

The LO BAT annunciator is used with the battery operation and will turn ON to indicate that the battery has less than one hour useful life before recharging will be required. If continued use further drains the battery, no change in operation will occur until just before the battery voltage drops to a level where operation is affected. At this level, the indicator will automatically turn itself off. Refer to the Optional Battery Pack Operation section of this manual for more details.

UNDER/PWC1

The UNDER annunciator is used to signal that the displayed weight is less than the minimum value of acceptable weight used in the Checkweigher feature. Note that this annunciator is active only when the Checkweigher feature is enabled.

The PWC1 annunciator is turned on to indicate that the displayed weight is equal to or greater than the weight value stored as preset number 1. Note that this annunciator is active only when the Preset Weight Comparator feature has been enabled.

ACCEPT/PWC2

The ACCEPT annunciator is used to signal that the displayed weight is within the acceptable weight limits for the Checkweigher feature. That is, it is equal to or greater than the minimum acceptable weight and equal to or less than the maximum acceptable weight. Note that this annunciator is active only when the Checkweigher feature has been enabled.

The PWC2 annunciator is turned on to indicate that the displayed weight is equal to or greater than the weight value stored as preset number 2. Note that this annunciator is active only when the Preset Weight Comparator feature has been enabled.

OVER/PWC3

The OVER annunciator is used to signal that the displayed weight is equal to or greater than the minimum value of over weight used in the Checkweigher feature. Note that this annunciator is active only when the Checkweigher feature has been enabled.

The PWC3 annunciator is turned on to indicate that the displayed weight is equal to or greater than the weight value stored as preset number 3. Note that this annunciator is active only when the Preset Weight Comparator feature has been enabled.

T

The T (tons) annunciator is located to the right of the weight display and is turned on to show that the displayed weight units is tons.

g

The g (grams) annunciator is located to the right of the weight display and is used to indicate that the displayed units of weight measurement is grams.

lb

The lb (pounds) annunciator is located to the left of the weight display and is turned on to show that the displayed weight units is pounds.

oz

The oz (ounces) annunciator is located to the right of the weight display and is turned on to show that the displayed weight units is ounces.

kg

The kg (kilograms) annunciator is located to the left of the weight display and is used to indicate that the displayed units of weight measurement is kilograms.

t

The t (tonnes, metric tons) annunciator is located to the right of the weight display and is used to indicate that the displayed units of weight measurement is tonnes (metric tons).

SETUP AND CALIBRATION

Your 205/210 indicator has been thoroughly tested and calibrated before being shipped to you. If you received the indicator attached to a scale, calibration is not necessary. If the indicator is being connected to a scale for the first time or recalibration is necessary for other reasons, proceed as indicated.

The calibration switch is located on a bracket on the inside of the enclosure rear panel. You may gain access to this switch simply by removing the calibration switch access screw on the rear panel. Refer to Figure No. 9.

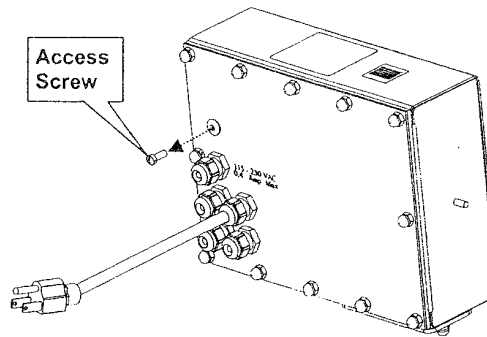

Figure No. 9

MODEL 205

During the setup and calibration process it will be necessary to enter operational parameters via the 205 keypad. Pressing the **TARE/ENTER** key (performs the same function as the **ENTER** key on the 210) will cause the data entered or displayed to be retained and the 205 to advance to the next prompt. The functions of the numeric keys are replaced by using the **UNITS/LEFT ARROW** and the **ASTERISK/UP ARROW** keys. The cursor location is identified by the blinking character and can be advanced to the left to the next position by pressing the **UNITS/LEFT ARROW** key. Pressing the **ASTERISK/UP ARROW** key will change the blinking character to the next value. Continue to press this key to "toggle" between the different available values for the setup parameter. Pressing the **ASTERISK** key when a setup parameter (not a parameter value) is displayed, will "backup" to the previous prompt.

MODEL 210

During the setup and calibration process it is necessary to enter operational parameters via the 210's keypad. Pressing the **ENTER** key without entering a new value will retain the current setting and advance the 210 to the next prompt. To change a setting, enter a new value and press the **ENTER** key. This will save the new value and advance the 210 to the next prompt. Pressing the **ASTERISK** key will "backup" to the previous prompt.



CAUTION: The membrane keypad is not to be operated with pointed objects (pencils, pens, fingernails, etc). Damage to keypad resulting from this practice will NOT be covered under warranty.

Enter Setup Mode

To enter the setup mode, with the indicator ON, insert a small screwdriver or other tool through the calibration switch access hole on the rear panel. Press and release the calibration switch. The menu SetUP will be displayed. Continue to press and release the switch to rotate through the beginning point for entering the setup mode.

SETUP	Setup Mode (starts at USA prompt)
A-d	Analog to Digital Filtering (starts at dFLT= prompt)
CAL	Calibration (starts at CAL1 prompt)
Sio	Serial Input/Output (starts at BAUD prompt)
Print	Print Tab Settings (starts at PORT prompt)
F SPAn	Fine Span Adjustment
Hi rES	Display high resolution weight mode
LoCoUt	Key lock out function
dAC	Digital to Analog Converter (If DAC board is installed, Calibration of 10 volt or 4 to 20 mA Analog Output)

If you press the **ENTER** key at the SetUP prompt, you may proceed through to the next section (up to and including fSPAn) by pressing the **ENTER** key.

SETUP AND CALIBRATION, Cont.



NOTE! Setup may be interrupted at any time. ALL data previously entered and finalized with the ENTER key will be retained in the non-volatile memory.

Pressing the calibration switch *at any prompt* will return you to the SETUP menu. To exit setup, press the **ASTERISK** key with any of the above menu selections displayed or cycle power at any time (press the **ON/OFF** key twice).

NOTE! With the exception of the SETUP prompt, the prompts displayed for each section are different if you push the calibration switch instead of pressing the **ENTER** key to proceed through the section. *For example*, if you press the calibration switch with the SETUP displayed, the next prompt displayed will be A-d. If you step through the setup prompts by pressing the **ENTER** key, the next prompt displayed will be A-d?. In addition, at a prompt with the ? displayed, you must press the **ENTER** key, the **1/YES** key then the **ENTER** key again to proceed with that section. To skip the section and advance you to the next menu selection, press the **ENTER** key twice.

SETUP

USA (domestic or international)

With SETUP displayed, press the **ENTER** key. The display will change to USA=. Press the **ENTER** key to show the current value. If the setting displayed is acceptable, press the **ENTER** key again to save it. Otherwise, using the numeric keys, **0/NO** or **1/YES**, enter the new setting, then press the **ENTER** key to save it.

USA = 1 (Domestic)

Date = mm/dd/yy
Trl = no
Cap + 4% to OC

USA = 0 (International)

Date = dd/mm/yy
Trl = yes
Cap + 9 grads to OC
PT printed with tare
Lamp test on power up

Lft (Legal For Trade)

Press the **ENTER** key to show the current value. If the setting displayed is acceptable, press the **ENTER** key again to save it. Otherwise, using the numeric keys, **0/NO** or **1/YES**, enter the new setting, then press the **ENTER** key to save it.

Lft = 1

Interval Settings (Int=) allowed
are: 1, 2, 5, 10, 20, 50

Lft = 0

Interval Setting (Int=) is
selectable from 1 to 99.

NOTE! When both *Lft=1* and *USA=1*, the followings results occur:

Scale must have between 100 and 10,000 divisions
Tra = .5 or 0 to 3
Inhibit serial data during input
Disables **COUNT** key
Date = mm/dd/yy
Trl = no
Cap + 4% to OC

NOTE! When *Lft=1* and *USA=0*, the followings results occur:

Uns = 1
Date = dd/mm/yy
Trl = yes
Cap + 9 grads to OC
PT printed with tare
Lamp test on power up

SETUP AND CALIBRATION, Cont.

Unit1= (Weighing Unit 1)

Press the **ENTER** key to show the current value. If the setting displayed is acceptable, press the **ENTER** key again to save it. Otherwise, using the numeric keys enter the new setting, then press the **ENTER** key to save it. Allowable values are:

0 = none	4 = oz (ounces)
1= tn (tons)	5 = kg (kilograms)
2= g (grams)	6 = tonnes (metric tons)
3 = lb (pounds)	7 = lb/oz (pounds/ounces)

Int= (Interval Setting)

Press the **ENTER** key to show the current value.

If LFT = 1 (Legal For Trade = YES), using the numeric keys enter the new setting, then press the **ENTER** key to save it. Allowable values are: 1, 2, 5, 10, 20 or 50.

If LFT=0 (Legal For Trade = NO), using the numeric keys enter the new setting, then press the **ENTER** key to save it. Allowable values are: 1 through 99.

In either case, if the setting displayed is acceptable, press the **ENTER** key again it.

dPP= (Decimal Point Setting)

Press the **ENTER** key to show the current value. If the setting displayed is acceptable, press the **ENTER** key again to save it. Otherwise, using the numeric keys enter the new setting, then press the **ENTER** key to save it. Allowable values are: 0, 1, 2 or 3.

0 = XXXXXX	2 = XXXX.XX
1 = XXXXX.X	3 = XXX.XXX

CAP= (Capacity)

Press the **ENTER** key to show the current value. If the setting displayed is acceptable, press the **ENTER** key again to save it. Otherwise, using the numeric keys enter the new setting, then press the **ENTER** key to save it. Allowable values are: 1 through 999,999.

NOTE! Capacity cannot exceed 999,999.

Unit2= (Weighing Unit 2)

Press the **ENTER** key to show the current value. If the setting displayed is acceptable, press the **ENTER** key again to save it. Otherwise, using the numeric keys enter the new setting, then press the **ENTER** key to save it. Allowable values are:

0 = none	4 = oz (ounces)
1= tn (tons)	5 = kg (kilograms)
2= g (grams)	6 = tonnes (metric tons)
3 = lb (pounds)	7 = lb/oz (pounds/ounces)



NOTE! The selection for Unit2 can not be the same as Unit1. In addition, dependent upon the selection for Unit1 and the interval and decimal point settings, not all unit combinations are available.

trA= (Zero Tracking Range)

Press the **ENTER** key to show the current value. If the setting displayed is acceptable, press the **ENTER** key again to save it. Otherwise, using the numeric keys enter the new setting, then press the **ENTER** key to save it. Allowable values are: 0 (disables Zero Tracking), .5, or 1 through 9.

SETUP AND CALIBRATION, Cont.

trL= (4% Zero Range)

Press the **ENTER** key to show the current value. If the setting displayed is acceptable, press the **ENTER** key again to save it. Otherwise, using the numeric keys, **0/NO** or **1/YES**, enter the new setting, then press the **ENTER** key to save it.

trL = 1 (Yes)
4% of scale capacity

trL = 0 (No)
Full capacity (no limit)

PUO= (Power-Up Zero Feature)

Press the **ENTER** key to show the current value. If the setting displayed is acceptable, press the **ENTER** key again to save it. Otherwise, using the numeric keys, **0/NO** or **1/YES**, enter the new setting, then press the **ENTER** key to save it.

PUO = 1 (Yes)
Automatic Re-Zero on Power-Up

PUO = 0 (No)
No Re-Zero on Power-Up

td= (12 or 24 Time Format) - Model 210 Only

Press the **ENTER** key to show the current value. If the setting displayed is acceptable, press the **ENTER** key again to save it. Otherwise, use the numeric keys to select the format (12 or 24 hour) of the Model 210 clock operation, then press the **ENTER** key to save it. Note that in the 24 hour format, 12 is added to all times after noon, i.e. 3 PM would be 1500.

td = 12
12 hour clock (3PM displays 3:00)

td = 24
24 hour clock (3PM displays 15:00)

d oUt= X,Y (Digital Output) - Model 210 Only

Press the **ENTER** key to show the current value. If the setting displayed is acceptable, press the **ENTER** key again to save it. Otherwise, use the numeric keys to select the X,Y values for the digital output, then press the **ENTER** key to save it.

d out= X, Y

where: X = State below cutoff (0 = LOW, 1 = High)
Y = Preset Number or Checkweigher Mode

- 0 = Digital Output is disabled
- 1 = Low State before cutoff with 1 active Preset
- 2 = Low State before cutoff with 2 active Presets
- 3 = Low State before cutoff with 3 active Presets
- 11 = High state before cutoff with 1 active Preset
- 12 = High state before cutoff with 2 active Presets
- 13 = High state before cutoff with 3 active Presets
- 4 = Low State before cutoff on Checkweigher Mode
- 14 = High state before cutoff on Checkweigher Mode

P-bAL= (Preset Print-On-Balance)

With only one Preset selected (d OUt= 1 or 11), an additional prompt P-bAL= (automatic Print on Balance) will be displayed. If selected (P-bAL=YES), when the weight equals (or is above) the preset value and all motion stops, the weight will be printed (if a printer is attached). Note, that the weight must go below 50% of the preset value before another print operation can be performed.

If the setting displayed is acceptable, press the **ENTER** key to save it. Otherwise, using the numeric keys, **0/NO** or **1/YES**, enter the new setting, then press the **ENTER** key to save it.

P-bAL = 1 (Yes)
Automatic Print on Balance
Enabled

P-bAL = 0 (No)
Automatic Print on Balance
Disabled

SETUP AND CALIBRATION, Cont.

P-bAL= (Checkweigher Print-On-Accept)

With Checkweigher selected (dOUT= 4 or 14), an additional prompt P bAL, Print on Balance, (automatic print on accept) will be displayed. If selected (P-bAL=YES), when the scale weight is stable and in the accept range of the checkweigher, the weight will be printed (if a printer is attached).

If the setting displayed is acceptable, press the **ENTER** key to save it. Otherwise, using the numeric keys, **0/NO** or **1/YES**, enter the new setting, then press the **ENTER** key to save it.

P-bAL = 1 (Yes)

Automatic Print on Accept Enabled

P-bAL = 0 (No)

Automatic Print on Accept Disabled

SLEEP= (Sleep Mode Feature)

The Sleep Mode feature conserves battery power when the indicator remains unused for a selected period of time. With the feature enabled, the load cell excitation will be reduced and the display will be blank.

Press the **ENTER** key to show the current status of this feature. If a number other than 0 is shown, this feature is selected and the number shown corresponds to the number of minutes of a stable zero weight reading before the indicator enters the sleep mode. If the setting displayed is acceptable, press the **ENTER** key again to save it. Otherwise, use the numeric keys to enter a new value (0 to 10) then press the **ENTER** key to store the new setting. Note that entry of a 0 disables this feature.

A oFF= (Auto Shutoff)

The Automatic Shutoff feature will automatically turn the indicator off (when it is not in use) after a predetermined period of inactivity to prolong battery life. To turn the instrument back on you must press the **ON / OFF** key.

Press the **ENTER** key to show the current status for this feature. A number other than 0 indicates that the auto shutoff feature is enabled and the displayed number corresponds to the number of minutes of stable weight displayed before the indicator is turned off automatically. Note that a 0 indicates the feature has been turned off. If the setting displayed is acceptable, press the **ENTER** key again to save it. Otherwise, use the numeric keys to enter a new value (0 to 10) then press the **ENTER** key to store the new setting.

CLtAr= (Clear Tare)

The Clear Tare feature allows the indicator to clear the Stored Tare weight when the Net weight goes below zero (a negative net weight after display of a positive net weight). With this feature enabled, the operator must re-set the tare after completion of a transaction when the load (container plus item) is removed from the scale.

Press the **ENTER** key to show the current value. If the setting displayed is acceptable, press the **ENTER** key again to save it. Otherwise, using the numeric keys, **0/NO** or **1/YES**, enter the new setting, then press the **ENTER** key to save it.

CLtAr = 1 (Yes)

Automatically clears Stored Tare
when Net weight goes below zero

CLtAr = 0 (No)

Stored Tare is not cleared when
Net weight goes below zero

The following is a typical example of the Clear Tare feature in use.

1. Place container on scale, then press **TARE** key (with diamond "T" symbol on 210).
2. Load container with item to be weighed and perform normal weighing operation.
3. Remove load (item *AND* container) from scale.
4. Scale weight returns to below zero (the weight of the container) and is then reset to zero.
5. Operator is required to repeat step 1 before next weighing operation.

SETUP AND CALIBRATION, Cont.

A - d (A - d?) - Analog to Digital Filtering

dFLt= (Digital Filtering)

With A - d (A - d?) displayed, press the **ENTER** key. The display will change to dFLt=. Press the **ENTER** key to show the current value. If the setting displayed is acceptable, press the **ENTER** key to save it. Otherwise, using the numeric keys enter the new setting, then press the **ENTER** key to save it. Allowable values are: 0, 1, 2 or 3. Note, that if you select 3 (Custom Filtering) two additional prompts will be displayed.

dFLt=	
0	Disabled – NO Filtering
1	MINIMAL FILTERING (sample rate = 2)
2	MODERATE FILTERING (sample rate = 1)
3	CUSTOM FILTERING

NOTE! The prompts, F= (Filter Level) and b= (Break Range) will only be displayed if you selected 3 (Custom Filtering) for the dFLt= (Digital Filtering) prompt.

F= (Filter Level)

Press the **ENTER** key to show the current setting for the filter level. The filter level is a number from 1 to 99 that corresponds to the level of filtering with 99 being the greatest filtering and 1 the least. To accept the value displayed, press the **ENTER** key, otherwise, use the numeric keys to enter a new value then press the **ENTER** key to save it.

b= (Break Range)

Press the **ENTER** key to show the current setting for the break range. The break range is a number from 1 to 255 that corresponds to the number of division change to break out of the filtering. Press the **ENTER** key to keep the displayed value or use the numeric keys to enter a new value and press the **ENTER** key to save the new setting. Note that entry of a 0 disables this feature.

Sr= (Sample Rate)

Press the **ENTER** key to show the current setting for the sample rate. The value displayed is the sample rate in samples per second. Press the **ENTER** key to save the displayed value or use the numeric keys to enter a new value (1 to 100) and press the **ENTER** key to save it.

UnS= (Motion Range)

Press the **ENTER** key to view the current setting for the range of motion detection. If the displayed value is acceptable, press the **ENTER** key to save it. Otherwise, use the numeric keys to enter the new range (the number of divisions of change permitted before indicating unstable), then press the **ENTER** key to save the new setting. Allowable range values are: 0 through 99 divisions.

SC= (Stable Count)

Press the **ENTER** key to view the current setting for the number of consecutive stable weight readings before indicating stable weight. This helps filter weight readings for stability for use with Auto Print on Balance, or and anything trying to capture stable weight. If the displayed value is acceptable, press the **ENTER** key to save it. Otherwise, use the numeric keys to enter a new value and press the **ENTER** key to save the new setting. Allowable values for the stable count are: 3 through 255.

SETUP AND CALIBRATION, Cont.

FILTER SETTING RECOMMENDATIONS

Non Critical Sample Rate

If the sample rate is not critical, as in static weighing, set dFLt= to "0" (no filtering), dFLt= "1" (F=6, b=12, Sr= 2/Sec), or dFLt= "2" (F=6, b=8, Sr= 1/Sec).

Critical Sample Rate

If the sample rate is critical, as in a filling operation, use the Custom Filtering (set dFLt= to "3").

1. Sr= SAMPLE RATE (1 to 50 samples/second) determination:

Set the sample rate as close as possible to produce a display graduation change for every graduation of material added to the scale.

$$\frac{\text{Material Flow Rate (lbs/second)}}{\text{Resolution}} = Sr$$

EXAMPLE: $\frac{100\text{lbs/sec}}{10\text{lbs}} = 10\text{s/s} = Sr$

2. b= BREAK RANGE (1 to 255 graduations) determination:

Turn the filtering off by setting the dFLt= setting to "0". Operate the system as it will be normally used and, by observation, determine the number of grads of instability that needs to be filtered out. Set the break range (b=) to that value.

$$\frac{\text{Weight Change}}{\text{Graduation Value}} = b$$

EXAMPLE: 20,000 x 10lb capacity scale with 800lb variation in the weight display.

$$\frac{800}{10} = b = 80$$

3. F= FILTER SETTING (1 to 99) determination: Set to desired results.
4. If stability is unacceptable with any setting of F=, reduce the sample rate and/or increase the break range, b= setting for increased filtering.

SETUP AND CALIBRATION, Cont.

CAL (CAL?) - Calibration

With CAL (CAL?) displayed, press the **ENTER** key. The display will change to show the current setting NO. To skip calibration and proceed to the Sio menu, press the **ENTER** key again. To begin calibration, press the numeric key **1/YES** then the **ENTER** key. After pressing the **ENTER** key the display will change to CAL1=.

NOTE! If the indicator was calibrated previously and the four (4) calibration "C" numbers were recorded, you may enter the values for C1 through C4 instead of using test weights. By entering the previously recorded "C" numbers, you can return to that calibration setting without having to use test weights. Refer to the Calibration "C" Number section of this manual for instructions on viewing the "C" numbers.

1. With "CAL1=" displayed, press the "diamond T" **TARE** key (**UNITS** key on the 205).
2. At the "C1=" prompt, press the **ENTER** to show the current value of the C1 number.
3. If the "C" number displayed is acceptable, press the **ENTER** key again to save it.
4. Otherwise, use the numeric keys to enter a new "C" number, then press the **ENTER** key to save it.
5. Repeat steps 2 through 4 for C2, C3 and C4.



NOTE! If any components have been changed that affect calibration and/or your scale is used in a commercial application and must be "Legal for Trade" you can not use "C" numbers to re-calibrate.

If you wish to use test weights (or are required to) for calibration, press the **ENTER** key at the "CAL1=" prompt.

CAL1= - (First Calibration Weight, 0 to Scale Capacity)

This is the first of two calibration weights: This weight could be ZERO (NO LOAD) or the TEST WEIGHTS (TEST LOAD). Press the **ENTER** key. The display will show 0.0.

If the first calibration weight is to be ZERO or NO LOAD, press the **ENTER** key.

If the first calibration weight is to be the TEST WEIGHTS or TEST LOAD, use the numeric keys to input the value of the calibrated test weights. Place these weights on the scale platform, then press the **ENTER** key.

Starting at the left and proceeding right, a series of dashes will appear on the display. The dashes will stay on the display momentarily, then starting at the left and proceeding right disappear, after which the display will show: CAL2=.

CAL2= - (Second Calibration Weight, 0 to Scale Capacity)

This is the second of two calibration weights. Press the **ENTER** key. The display will show 0.0.

If this second calibration weight is to be zero, make certain the scale platform is empty then press the **ENTER** key again.

If this second calibration weight is to be the test load, use the numeric keys and enter the total weight of the calibrated test weights. Place the weights on the scale platform and press the **ENTER** key.

Starting at the left and proceeding right, a series of dashes will appear on the display. The dashes will stay on the display momentarily, then starting at the left and proceeding right disappear, after which the display will show: Sio?.

Sio (Sio?) - Serial Input/Output

With Sio (Sio?) displayed, press the **ENTER** key. The display will change to show the current setting "no". To skip configuring the Sio (serial input/output) and proceed to the Print? menu, press the **ENTER** key again. To configure the Sio, press the numeric key **1/YES** then the **ENTER** key. After pressing the **ENTER** key, the display will change to bAud=.

SETUP AND CALIBRATION, Cont.

bAUd= (Serial Port Baud Rate)

Press the **ENTER** key to show the current value. If the setting displayed is acceptable, press the **ENTER** key again to save it. Otherwise, use the numeric keys to enter a new baud rate for the serial ports, then press the **ENTER** key to save it. Allowable values are:

12 = 1200 Baud	24 = 2400 Baud	48 = 4800 Baud
96 = 9600 Baud	19 = 19.2k Baud	38 = 38.4k Baud
76 = 76.8k Baud		

Prty= (Serial Port Parity)

Press the **ENTER** key to show the current value. If the setting displayed is acceptable, press the **ENTER** key again to save it. Otherwise, using the numeric keys enter the new setting, then press the **ENTER** key to save it. Allowable values are: 0, 1, or 2.

0 = NONE (No Parity)	1 = Odd Parity	2 = Even Parity
----------------------	----------------	-----------------

bitS= (Serial Port Data Bits)

Press the **ENTER** key to show the current value. If the setting displayed is acceptable, press the **ENTER** key again to save it. Otherwise, using the numeric keys enter the new setting, then press the **ENTER** key to save it. Allowable values are: 7 or 8.

StoP= (Serial Port Stop Bits)

Press the **ENTER** key to show the current value. If the setting displayed is acceptable, press the **ENTER** key again to save it. Otherwise, using the numeric keys enter the new setting, then press the **ENTER** key to save it. Allowable values are: 1 or 2.

Cont1= (Continuous Output Serial Port 1)

Press the **ENTER** key to show the current value. If the setting displayed is acceptable, press the **ENTER** key again to save it. Otherwise, using the numeric keys, **0/NO** or **1/YES**, enter the new setting, then press the **ENTER** key to save it.

Cont1= 1 (Yes)	Cont1= 0 (No)
Continuous Output	No Continuous Output

If you selected Cont1= 1 (Yes Continuous Output), an additional prompt, "tyPE=" will be displayed.

If you selected Cont1= 0 (No Continuous Output) proceed to the Weight On Demand section.

tyPE= (Continuous Output Format)

Press the **ENTER** key to show the current value. If the setting displayed is acceptable, press the **ENTER** key again to save it. Otherwise, using the numeric keys enter the new setting, then press the **ENTER** key to save it. Allowable values are: 0, 1, 2 or 3.

0 = SMA	1 = SB-400	2 = SB-200	3 = Rice Lake IQ355
---------	------------	------------	---------------------

If SMA is selected, the data will be transmitted in the following format:

```
<lf><s><r><n><m><f><xxxxxx.xxx><uuu><cr>
```

Where:

lf =	Line Feed	
s =	Flags	Z = center of Zero, O = Overcap, E = zero Error, e = weight not currently being displayed
r =	Range	1, 2, 3, ...
n =	Mode	G = Gross, T = Tare, N = Net
m =	Motion	M = Motion, " "(blank) = no motion
f =	Custom	Custom flag
xxxxxx.xxx =	Weight	Six digits with decimal point
uuu =	Units	ton, lb, l/o, oz, t, kg, g
cr =	Carriage Return	(hex 0D)

SETUP AND CALIBRATION, Cont.

If SB-400 or Computer is selected, the data will be transmitted in the following format:

`<s><xxxxxx><d><uu><m><cc><cr>`

Where:

s =	Sign	"-" = negative, " " (<i>blank</i>) = positive
xxxxxx.xxx =	Weight	Six digits
d =	Decimal point	Added to string if enabled in setup
uu =	Units	tn, lb, l/o, oz, t, kg, g
m =	Mode	G = Gross, N = Net
cc =	Weight Status	OC = overcap CZ = center of zero MO = motion ee = weight not currently being displayed
cr =	Carriage Return	(hex 0D)

The SB-80, SB-300 (*multiple displays not supported*) and WinVRS use the SB-400 format.

If SB-200 is selected, the data will be transmitted in the following format:

`<cr><s><xxxxxx><d><c><uu><m> ETX`

Where:

cr =	Carriage Return	(hex 0D)
s =	Sign	"-" = negative, " " (<i>blank</i>) = positive
xxxxxx.xxx =	Weight	(with leading zeros)
d =	Decimal point	Embedded into weight (after weight dpp=0)
c =	status	m = motion o = overcap e = weight not currently being displayed
uu =	Units	tn, lb, l/o, oz, t, kg, g
m =	Mode	G = Gross, N = Net
ETX =	End of TeXt	(hex 03) MUST terminate ALL serial commands

If Rice Lake IQ355 is selected, the data will be transmitted in the following format:

`<stx><polarity><wwwwwww><units><g/n><status><crlf>`

Where:

stx =	Start of TeXt	(hex 02)
polarity =	Sign	"-" = negative, " " (<i>blank</i>) = positive
wwwwwww =	Weight	Seven digits
units =	Units	" " (<i>blank</i>) = none, L = lb, K = kg, T = tons, G = grams, O = ounces
g/n	Mode	G = Gross, N = Net
status	status	" " (<i>blank</i>) = valid I = invalid M = motion O = overcap
CRLF =	Carriage Return with Line Feed	(hex 0D) with (hex 0A)

SETUP AND CALIBRATION, Cont.

Weight On Demand

If continuous output has not been selected for Serial Port 1 (Cont1=NO), the 205/210 indicator will respond to a weight request (ENQ).

The host device (computer) sends:

ENQ - (hex 05)

The 205/210 will respond:

<s><xxxxxx><d><uu><m><cc><cr>

Where:

s =	Sign	"-" = negative, " " (<i>blank</i>) = positive
xxxxxx.xxx =	Weight	Six digits
d =	Decimal point	Added to string if enabled in setup
uu =	Units	tn, lb, l/o, oz, t, kg, g
m =	Mode	G = Gross, N = Net
cc =	Weight Status	OC = overcap CZ = center of zero MO = motion ee = weight not currently being displayed
cr =	Carriage Return	(hex 0D)

NOTE! The Weight On Demand function is not available for Serial Port 2.

Cont2= (Continuous Output Serial Port 2)

Press the **ENTER** key to show the current value. If the setting displayed is acceptable, press the **ENTER** key again to save it. Otherwise, using the numeric keys, 0/NO or 1/YES, enter the new setting, then press the **ENTER** key to save it.

Cont2= 1 (Yes)

Continuous Output

Cont2= 0 (No)

No Continuous Output

If you selected Cont2= Yes (Continuous Output) an additional prompt, "tyPE=" will be displayed.

tyPE= (Continuous Output Format)

Press the **ENTER** key to show the current value. If the setting displayed is acceptable, press the **ENTER** key again to save it. Otherwise, using the numeric keys enter the new setting, then press the **ENTER** key to save it. Allowable values are: 0, 1, 2 or 3.

0 = SMA

1 = SB-400

2 = SB-200

3 = Rice Lake IQ355

NOTE! See Continuous Output Serial Port 1, tyPE= for description of output formats.

Print (Print?) - Print Tab Settings

With Print (Print?) displayed, press the **ENTER** key. The display will change to show the current setting "no". To skip configuring the Print Tab Settings and proceed to the FSPAn? menu, press the **ENTER** key again. To configure the Print Tab Settings, press the numeric key 1/YES then the **ENTER** key. After pressing the **ENTER** key the display will change to Port=.

The general format for the input is A = YY.XX where A is the character identifying the data printed, YY is the number of lines down and XX is the number of spaces to the right.



NOTE! Enter 00 in either location, YY or XX, to disable the data from printing.

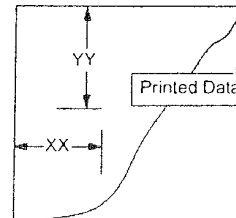

SETUP AND CALIBRATION, Cont.

Port= (Select Port for Printer)

Press the **ENTER** key to show the current value. If the setting displayed is acceptable, press the **ENTER** key again to save it. Otherwise, using the numeric keys enter the new setting, then press the **ENTER** key to save it. Allowable values are: 1 or 2.



NOTE! Although either port can be used for the printer port, it is recommended to use the bi-directional port 1 with a bi-directional cable.

HoUr= (Time Print Location)

Press the **ENTER** key to show the current setting for the location of the time printing. If the setting displayed is acceptable, press the **ENTER** key again to save it. Otherwise, use the numeric keys to enter the new location then press **ENTER** to save it.

dAtE= (Date Print Location)

Press the **ENTER** key to show the current setting for the location of the date printing. If the setting displayed is acceptable, press the **ENTER** key again to save it. Otherwise, use the numeric keys to enter the new location then press **ENTER** to save it.

CnC n= (Consecutive Number Print Location)

Press the **ENTER** key to show the current setting for the location of the consecutive number printing. If the setting displayed is acceptable, press the **ENTER** key again to save it. Otherwise, use the numeric keys to enter the new location then press **ENTER** to save it.

GroSS= (Gross Weight Print Location)

Press the **ENTER** key to show the current setting for the location of the Gross weight printing. If the setting displayed is acceptable, press the **ENTER** key again to save it. Otherwise, use the numeric keys to enter the new location then press **ENTER** to save it.

tArE= (Tare Weight Print Location)

Press the **ENTER** key to show the current setting for the location of the Tare weight printing. If the setting displayed is acceptable, press the **ENTER** key again to save it. Otherwise, use the numeric keys to enter the new location then press **ENTER** to save it.

nEt= (Net Weight Print Location)

Press the **ENTER** key to show the current setting for the location of the Net weight printing. If the setting displayed is acceptable, press the **ENTER** key again to save it. Otherwise, use the numeric keys to enter the new location then press **ENTER** to save it.

G ACC= (Gross Weight Accumulator Print Location)

Press the **ENTER** key to show the current setting for the location of the Gross weight accumulator printing. If the setting displayed is acceptable, press the **ENTER** key again to save it. Otherwise, use the numeric keys to enter the new location then press **ENTER** to save it.

n ACC= (Net Weight Accumulator Print Location)

Press the **ENTER** key to show the current setting for the location of the Net weight accumulator printing. If the setting displayed is acceptable, press the **ENTER** key again to save it. Otherwise, use the numeric keys to enter the new location then press **ENTER** to save it.

CoUnt= (Count "number of pieces on the scale" Print Location) - Model 210 Only

Press the **ENTER** key to show the current setting for the location of the Count (number of pieces on the scale) printing. If the setting displayed is acceptable, press the **ENTER** key again to save it. Otherwise, use the numeric keys to enter the new location then press **ENTER** to save it.

EACH= (Piece Weight Print Location) - Model 210 Only

Press the **ENTER** key to show the current setting for the location of the Piece weight printing. If the setting displayed is acceptable, press the **ENTER** key again to save it. Otherwise, use the numeric keys to enter the new location then press **ENTER** to save it.

SETUP AND CALIBRATION, Cont.

CrLF= (Carriage Return Line Feed) - Data Format Termination

Data transmitted from the serial I/O port can be terminated with a single carriage return and either no line feed or a single line feed command. Press the **ENTER** key to view the current setting. A "YES" on the display means the data will be terminated with a carriage return AND a line feed while a "no" on the display means the data will be terminated with a single carriage return only.

If the setting displayed is acceptable, press the **ENTER** key again to save it. Otherwise, using the numeric keys, **0/NO** or **1/YES**, enter the new setting, then press the **ENTER** key to save it.

EoP= (End-Of-Print Line Feeds)

At the end of a data transmission to a printer, the indicator can transmit a pre-selected number of line feed commands to space the paper in the printer to the desired position for withdrawal or for the next print.

Press the **ENTER** key to view the current setting. If the displayed value is acceptable, press the **ENTER** key to save it. Otherwise, use the numeric keys to enter the new the number of End-Of-Print linefeeds, then press the **ENTER** key to save the new setting. Allowable values are: 0 through 99.



NOTE! The FSPAN and Hi rES modes require a load of 10% of Capacity be on the scale before adjustments can be made.

F SPAn (FSPAN?) - Fine Span Adjustment

With the *F SPAN?* prompt displayed after pressing the **ENTER** key at the last Print prompt:

With FSPAN? displayed, press the **ENTER** key. The display will change to show the current setting "no". To skip the Fine Span Adjustment and return to the **SETUP** menu, press the **ENTER** key again. To perform the Fine Span Adjustment, place a calibrated test weight on the scale and press the numeric key **1/YES** then the **ENTER** key.

After pressing the **ENTER** key, the display will change to show the amount of the test weight and the annunciators will alternately flash off and on i.e. (all ON, weighing unit off, then all OFF, weighing unit ON). Press the **1/YES** to increase the span OR press the **0/NO** key to decrease the span. Press the **ASTERISK** key to return to the previous prompt or press the **ENTER** key to exit FSPAN? and return to the **SETUP** menu.

With the *F SPAN* prompt displayed after pressing the Calibration switch:

With F SPAN displayed, place a calibrated test weight on the scale and press the **ENTER** key. After pressing the **ENTER** key, the display will change to show the amount of the test weight and the annunciators will alternately flash off and on (all ON, weighing unit off, then all OFF, weighing unit ON). Press the **1/YES** to increase the span OR press the **0/NO** key to decrease the span. Press the **ASTERISK** key to return to the previous prompt or press the **ENTER** key to exit F SPAN and return to the **SETUP** menu.

Hi rES - Display High Resolution Weight

With Hi rES on the display, pressing the **ENTER** key will show the active weight in "high resolution" mode (in 1/10 interval). Press the **PRINT** key to print the weight (followed by the text TEST) via the selected printer output port enabled during setup and calibration.

LoCoUt - Key Lock Out Function

With LoCoUt on the display, pressing *any* key will display "LoCd" (locked) or "UnLoCd" (unlocked) for the current key state. Pressing a locked key during normal operation will result in a 1/2 second display "LoCd" and the key will be ignored. To exit the LoCoUt function, press the calibration switch or cycle power (press the **ON/OFF** key twice).



NOTE! The menu selections Hi rES and LoCoUt can only be selected using the calibration switch.

SETUP REVIEW

The 205/210 indicators allow several operational parameters to be reviewed and changed without breaking the calibration seal. These operational parameters are:

- Power Up Zero Reset Enable/Disable
- Time Format
- Digital Output Control Enable/Disable
- Sleep Mode Feature Enable/Disable
- Auto Shutoff Feature Enable/Disable

- Serial Input / Output Configuration
 - Baud Rate
 - Parity
 - Number of Data Bits
 - Number of Stop Bits
 - Continuous Output Port 1
 - Continuous Output Format
 - Continuous Output Port 2
 - Continuous Output Format

- Print Tab Settings
 - Printer Port Selection
 - Time
 - Date
 - Consecutive Number
 - Gross Weight
 - Tare Weight
 - Net Weight
 - Gross Weight Accumulator
 - Net Weight Accumulator
 - Count (*Model 210 Only*)
 - Piece Weight (*Model 210 Only*)

To enable the Setup Review feature, with the indicator ON:

1. Press the **ASTERISK** key. The indicator will respond by showing the FunCt= (Function) prompt and alternately flashing off and on (all ON, weighing unit off, then all OFF, weighing unit ON) the annunciators.
2. Press the **ZERO/REVIEW** key. The display will change to the prompt for the selection of power-up zeroing (PUO=).
3. Using the same procedure as described in the Setup and Calibration section of this manual, make the required changes.
4. Press the **ASTERISK** key to return to the previous prompt.
5. To exit Setup Review, press the **ENTER** key to step the remaining prompts OR at anytime, cycle the power (press the **ON/OFF** key twice).

CALIBRATION "C" NUMBERS

The "C" numbers are displayed only during the Test mode operation by pressing the **ASTERISK** key then the **UNITS/TEST** key. The "C" numbers are shown at the end of the test operation and each number is displayed for approximately 4 seconds, allowing you to record them. Each number may be up to three (3) digits in length. By recording these numbers you will be able to return the indicator to its present calibration settings without using test weights simply by entering the "C" numbers. Refer to the Setup and Calibration, "CAL" section of this manual for instructions on using the "C" numbers.



If any components have been changed that affect calibration and/or your scale is used in a commercial application and must be "Legal for Trade" you can not use "C" numbers to re-calibrate.

ACCUMULATORS

To *view* the NET accumulator:

1. Press the **ASTERISK** key then the **NET/GROSS** key.
2. Press the **ASTERISK** key to return to normal operation.

To *print* the NET accumulator:

1. Press the **ASTERISK** key, the **NET/GROSS** key, then the **PRINT** key
2. The indicator will return to normal operation when printing has been completed.

To *clear (zero)* the NET accumulator:

1. Press the **ASTERISK** key, the **NET/GROSS** key, then the **ZERO** key
2. Press the **ASTERISK** key to return to normal operation.

To *view* the Gross accumulator:

1. Press the **ASTERISK** key then the **NET/GROSS** key twice.
2. Press the **ASTERISK** key to return to normal operation.

To *print* the Gross accumulator:

1. Press the **ASTERISK** key, the **NET/GROSS** key twice, then the **PRINT** key
2. The indicator will return to normal operation when printing has been completed.

To *clear (zero)* the Gross accumulator:

1. Press the **ASTERISK** key, the **NET/GROSS** key twice, then the **ZERO** key
2. Press the **ASTERISK** key to return to normal operation.

MODEL 210 Only

To *view* the Count accumulator:

1. Press the **ASTERISK** key then the **COUNT/SAMPLE** key.
2. Press the **ASTERISK** key to return to normal operation.

To *print* the Count accumulator:

1. Press the **ASTERISK** key, the **COUNT/SAMPLE** key, then the **PRINT** key
2. The indicator will return to normal operation when printing has been completed.

To *clear (zero)* the Count accumulator:

1. Press the **ASTERISK** key, the **COUNT/SAMPLE** key, then the **ZERO** key
2. Press the **ASTERISK** key to return to normal operation.

BEFORE YOU CALL FOR SERVICE

The 205/210 indicators have been designed to provide you with years of trouble-free operation. However, should you experience a problem, please refer to the troubleshooting guide below before you call for service. The following describes several types of symptoms along with suggested remedies.

PROBLEM	POSSIBLE SOLUTIONS
Display does not turn on	<p>AC operation: Is the AC power cord fully inserted into the wall receptacle? Check wall receptacle for proper AC power. Try another electrical appliance in the same receptacle, does it work? Check the circuit breaker. Has there been power failure?</p> <p>Battery operation: Check if battery is installed and correctly. Is battery discharged - replace or recharge.</p>
Incorrect weight displayed	<p>Has the instrument been calibrated? Insure that the scale platform isn't touching an adjacent object. Check the load cell connector wiring. If using four (4) wire load cells, insure the sense lead jumpers (J4 & J5) are installed. Have proper operation procedures been followed?</p>
Indicator will not display weight	<p>Refer to Error Codes section and make certain that the "oCAP" message is not displayed. If so, and scale is not loaded, perform the calibration sequence.</p>
The printer prints but does not use the Print Tab Settings or prints a test ticket	<p>The print tab setting or visual ticket format must be selected prior to beginning the weighing operation or just prior to printing the ticket.</p> <p>To select the ticket format prior to beginning the weighing operation:</p> <ol style="list-style-type: none">1. Press the ASTERISK key then the PRINT key. The display will change to the "Prt=".2. Press the ENTER key to show the current value.3. If the value displayed is acceptable, press the ENTER key again to save it.4. If the displayed value is incorrect (or another ticket format is desired), use the numeric keys to enter the new value, then press the ENTER key to save it. <p>To select the ticket format just prior to printing the ticket:</p> <ol style="list-style-type: none">1. Press the desired format number.2. Pressing the PRINT key. <p>Allowable values for ticket formats are:</p> <ul style="list-style-type: none">0 = print tab settings1 = visual ticket format 12 = visual ticket format 2

NOTE! When a print format is selected (by either method), it will remain active until changed by the operator.

ERROR CODES

The 205/210 indicators are equipped with software that indicates when an error in the operation takes place. The following lists the error codes displayed by the 205/210 along with their meaning. Should you encounter an error code, please refer to this list for the cause.

CALbtn (Calibration Button)

CALbtn will be displayed (until the condition changes), on power-up if the calibration switch is pressed in by the operator, the calibration access screw is the wrong length and is depressing the switch, the switch is disconnected from the PC board, or the switch is defective.

CORRECTIVE ACTION: Release the switch. Insure correct screw (#10 x ½ Stainless Steel fillister head) was installed for the calibration access screw. Referring to Figure No. 6, make sure calibration switch cable is plugged into P7 on the PC board. Replace calibration switch assembly. Consult your scale service provider.

ConFiG (Configuration)

E²PROM checksum failure. Indicates improper stored calibration data, calibration is necessary.

CORRECTIVE ACTION: Recalibrate with calibrated test weight.

Error

An invalid keypad entry was attempted:

- A. **PRINT** key pressed with a negative weight.
- B. **TARE** key pressed to enter a push button tare value of a negative value.
- C. **ENTER** key pressed to enter a tare weight value that exceeds the scale capacity.
- D. **ENTER** key pressed to enter a tare weight value that is inconsistent with the scale division value (i.e. attempt to enter a tare of 123 with scale divisions of 5).
- E. **ZERO** key pressed when the gross weight is outside the scale zero weight range.
- F. **lb/kg** key pressed to change to kilograms when the kilogram tare weight value exceeds 4 digits in length.

CORRECTIVE ACTION: Determine which of the reasons for the error display is applicable and take the appropriate corrective action.

ErrAh (Analog Error High)

1. The load cell input is above the range of the indicator.

CORRECTIVE ACTION: Check for improper load cell wiring, excessive load, and for output of 1 to 40mV.

2. Load cell or circuit failure.

CORRECTIVE ACTION: Consult your scale service provider.

ErrAL (Analog Error Low)

1. The load cell input is below the range of the indicator.

CORRECTIVE ACTION: Check for improper load cell wiring and for output of 1 to 40mV.

2. Load cell or circuit failure.

CORRECTIVE ACTION: Consult your scale service provider.

Err1

A program checksum mismatch has been detected.

CORRECTIVE ACTION: Consult your scale service provider.

Err3

Internal RAM failure.

CORRECTIVE ACTION: Consult your scale service provider.

HuH?

UNITS key pressed in an attempt to perform a "unit" conversion that is not allowed.

CORRECTIVE ACTION: Determine the reason for the error display and take the appropriate corrective action.

ERROR CODES, Cont.

notArE

NET key pressed with no stored tare weight value.

CORRECTIVE ACTION: Determine the reason for the error display and take the appropriate corrective action.

OCAP (Over Capacity)

The load on the scale exceeds the scale capacity plus nine (9) divisions.

CORRECTIVE ACTION: Remove the over capacity load from the scale platform. May indicate miscalibration.

-oF- (Overflow)

The indicator is attempting to display a positive number greater than six (6) digits in length or a negative number of more than five (5) digits.

CORRECTIVE ACTION: Return to Gross Weight mode and review Tare value. May indicate miscalibration.

toobIG

UNITS key pressed in an attempt to perform a "unit" conversion where the interval would have been greater than 50.

CORRECTIVE ACTION: Determine the reason for the error display and take the appropriate corrective action.

UnStb (Unstable)

Motion is present when trying to power up, print, zero or perform a push button tare function.

CORRECTIVE ACTION: Wait for a stable weight display (*STABLE* annunciator on) before performing any of these operations.

CALIBRATION SEAL INSTALLATION

If your 205/210 Weight Indicating Instrument is used in a commercial application it must be tested and sealed by your local weights and measurements official. The 205/210 is designed to accept a lead and wire security seal to prevent unauthorized access to the calibration adjustments. Refer to Figure No. 10 for details on the installation of the seal.

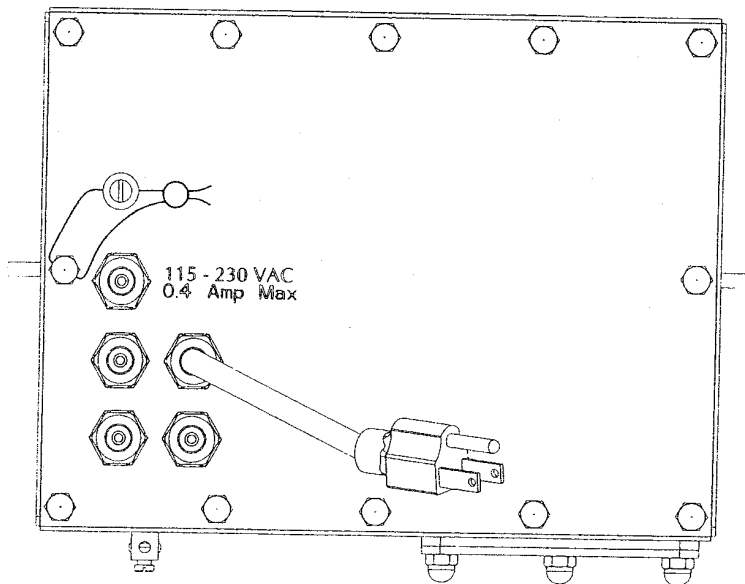

Figure No. 10

OPTIONAL BATTERY OPERATION

The 205/210 indicators can operate from a readily available Sealed Lead-Acid Camcorder type battery (*not included*). If you wish to operate the indicator from a battery, you must first obtain and install a CAM-350 Type, 12 volt, 2000 mAh (2.0 Ah) battery before operation can begin. The battery is contained inside the instrument and is easy to install. Access is via a removable panel on the bottom of the indicator (See Figure No. 11). The battery can be purchased from the Cardinal Scale Parts Department (p/n 6800-0018) or ordered from the following companies online:

- www.discountcell.com
- www.ebatts.com
- www.mobilizenow.com
- www.planetbattery.com

The battery life of the indicator varies significantly with the way the indicator is used (e.g. the longer more display segments are on, the faster the battery will discharge). The battery used in the 205/210 indicator will power it continuously, with four 350 ohm load cells, for from 5.5 hours (with maximum display segments on) to 9 hours (with minimum display segments on). This time can be extended if the Sleep and Auto-Shutoff features are employed.

LOAD CELLS	BATTERY LIFE (in Hours)
1	7 to 13
2	6.5 to 11.5
3	6 to 10
4	5.5 to 9
6	5 to 7.5
8	4.5 to 6.5



NOTE! The 205/210 indicators are shipped with the load cell excitation voltage set to 12V (J3 *open*). To operate from a 12 VDC battery, the load cell excitation voltage **MUST** be set to 8V (J3 *closed*). Battery operation with the load cell excitation voltage set to 12V will result in an unstable weight display. Refer to Figure No. 6 for location of J3.

Battery Installation

1. Remove the AC power to the indicator.
2. Referring to Figure No. 11, remove the three acorn nuts securing the Battery Access Cover to the bottom of the indicator, then remove the cover exposing the battery access opening.
3. Insure the (-) negative polarity markings of the battery are positioned facing up (towards the front of the indicator) and the alignment notch in the battery is to the left.
4. Slide the battery into the opening, compressing the battery ejector spring, until you feel resistance and the battery is almost flush with the bottom of the indicator.
5. Replace the Battery Access Cover and install the three acorn nuts removed earlier, securing the battery in place.

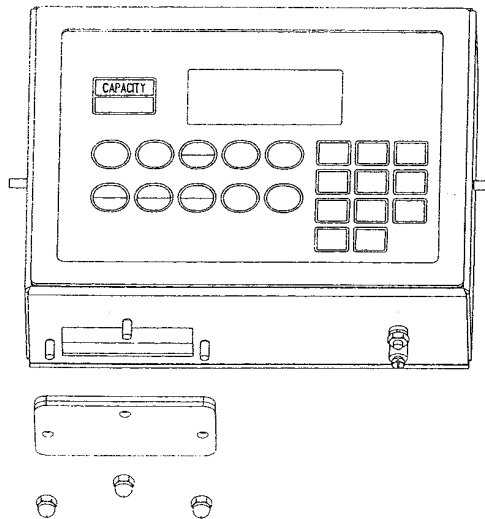

Figure No. 11

Battery Removal

1. Remove the AC power to the indicator.
2. Referring to Figure No. 11, remove the three acorn nuts securing the Battery Access Cover to the bottom of the indicator.
3. Remove the cover, exposing the battery access opening.
4. An internal spring will push the battery partially out of the opening. Grasp the end of the battery and slide it out of the opening.
5. Replace the Battery Access Cover and install the three acorn nuts remove earlier.

OPTIONAL BATTERY OPERATION, Cont.

Discharging the Battery

The battery is discharging when the indicator is operated without the AC power cord plugged into a wall outlet. The LO BAT annunciator on the indicator keypad serves to indicate the state of the battery. When the indicator is operating by battery power, and the battery has sufficient charge to power the indicator, the LO BAT annunciator is off. If the battery becomes discharged while the indicator is in use, the LO BAT annunciator will turn ON to indicate the battery needs to be charged. When this occurs, the battery will have sufficient charge to power the indicator for a short time (less than 1 hour of operation) before recharging is required.

If continued use further drains the battery to a level where the battery is unable to adequately power the indicator, the indicator will turn off automatically to prevent damaging the battery.

NOTE! If the battery has become severely discharged, the indicator may not respond at all when turned on. This is a safety feature to prevent the indicator from being powered up when the battery voltage is excessively low. Plug the indicator into the AC wall outlet to charge the battery.



Due to the nature of batteries, shutting the indicator OFF will cause the battery to recover slightly. If the indicator is operated after turning itself off, it may run for a few minutes before the LO BAT annunciator turns ON again. If the battery is too discharged to power the indicator, it will automatically turn itself off when the **ON/OFF** key is pressed.

Charging the Battery

The battery can be recharged with the indicator's built-in charger. Note that the battery can be left connected to the charger indefinitely, without risk of damage.

Cyclic Operation

When operating the indicator totally from battery power and only recharging when the batteries are low, place the Battery Charge Mode jumper(J1) in the FULL position. For the location of the Battery Charge Mode jumper(J1), refer to Figure No. 6.

Back-Up Operation

When operating the indicator from commercial power and using the battery to supply power only in the event of a power loss, place the Battery Charge Mode jumper(J1) in the TRICKLE position. For the location of the Battery Charge Mode jumper(J1), refer to Figure No. 6.

When the battery installed in a indicator needs to be charged, simply plug the AC power cord into a wall outlet and charging will begin. Note that operating the indicator during charging only minimally affects the charge time of the battery. The indicator can operate at a 100% duty cycle and will only prolong the charge time by less than 20%. Note too that charge time is dependent on the depth of the discharge and will vary from one application to the next, but will typically not exceed 10 hours even with the indicator turned on.



NOTE! While the 12 VDC battery is charging, the LO BAT annunciator will remain ON until the battery is charged to approximately 10 volts. Upon reaching that level, the LO BAT annunciator will turn off. This DOES NOT mean the battery is fully charged, only that the battery has reached a charge sufficient to turn off the LO BAT annunciator. At the level of charge where the LO BAT annunciator turns OFF, without further charging, the indicator will only operate for a few minutes before turning ON the LO BAT annunciator again, indicating additional charging is required.

OPTIONAL BATTERY OPERATION, Cont.

Optimum Battery Performance

The life of the battery depends greatly on the duty cycle of the indicator, depth of discharge and operating temperature. The battery will normally provide 10 hours of continuous operation within an operating range of 14 to 104 °F (-10 to +40 °C). Several steps can be taken to optimize the performance and life of the battery.

1. Enable the Auto Shut-Off feature. This feature will cause the indicator to shut itself off after the period of inactivity selected in setup, thus preserving the battery. (Refer to the Setup and Calibration section for an explanation of the Auto Shut-Off feature).
2. If possible, plug the AC power cord into a wall outlet after each work shift to allow the battery to recharge. This will minimize the depth of discharge and greatly increase the number of cycles the battery can undergo.
3. If conditions permit, avoid charging and discharging the battery in extreme cold. Due to the chemistry of batteries, low temperatures decrease the capacity of the battery significantly causing a greater depth of discharge at colder temperatures than at room temperature. The battery will function without problems at temperatures as low as 14 °F (-10 °C) but will not last as many cycles as it would at room temperature.
4. Avoid storing the battery after discharging. If the battery is to be left for several days or more, make certain that it is charged before storage. The optimum environment for batteries is to charge while stored. The type of charger used in the indicator will not damage the batteries in any way even if the battery is left charging indefinitely.

APPENDIX A – ANALOG OUTPUT OPTION (DAC) BOARD

This appendix describes the installation, setup and calibration of the optional Analog Output Option DAC (Digital to Analog Converter) board. This option consists of both a 0 to 10 volt and 4 to 20 mA analog output.

The Analog Output Option (DAC) board (Cardinal p/n 8200-C210-0A) is a 14-bit (16,383 states) analog representation of the displayed weight. The maximum load resistance for the current output is 500 ohms. The minimum load resistance for the voltage output is 2K ohms. Connections are made via a terminal block on the back of the option board. Refer to Figure No. 12 for the connector pin layout.

The 205/210 indicators feature complete "ranging" for DAC output. Users may select a weight range to be used for a selectable voltage range. This covers all current indicators/users and expands the capabilities for new applications. The 205/210 indicators also have auto-detect for option board installation. When the DAC board is found, additional prompts will be added to Setup. The main menu adds "dAC" (dAC?) after "LoCoUt". In addition, the calibration sequence includes the steps necessary to calibrate the analog output.

INSTALLATION

Mounting the DAC Board

NOTE! Should your indicator come with the DAC board already installed, the following information describing the mounting of the board does not apply. Proceed to the Cable Installation section.

1. Make sure the power to the indicator is OFF. Unplug the AC adapter and/or remove the battery.
2. Remove the 12 acorn nuts securing the back panel to the main housing.
3. Lift the back panel from the main housing, taking care not to stretch the cable and wires between the panel and main housing.
4. Locate the threaded mounting stud (below J2) and connector P5 on the main board.
5. To install the DAC board, carefully align the DAC board P1 (pins on trace side of DAC board) with connector P5 on the main board.
6. Align the hole in the DAC board with the threaded mounting stud (below J2) on the main board.
7. Apply even downward pressure to the end of the DAC board with P1.
8. Using the lock washer and hex nut supplied with the DAC board, secure the DAC board to the main board.

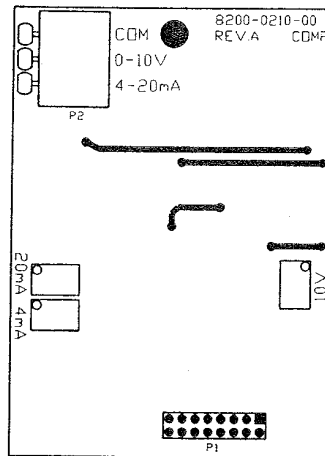

Figure No. 12 - DAC (Rear View)

Cable Installation

1. Loosen a cable gland connector for the Analog Output cable. The gland connector(s) are located on the rear panel of the enclosure.
2. Slip a two wire cable through the gland connector and into the enclosure.
3. Remove 2" of the outer insulation jacket then remove 1/4" of insulation from each of the wires.
4. Connect each of the wires to the terminal block (P2).
5. To terminate, first press down on the release bar for the terminal, insert the wire into the opening then allow the release bar to return to its original position, locking the wire in place. Repeat the procedure until all of the wires are in place.

P2 TERMINAL BLOCK

PIN NO.	Function
COM	Common
0-10V	0 to 10 volt output (2K Ω Min. Load)
4-20 mA	4 to 20 mA current output (500 Ω Max. Load)

CALIBRATION of the ANALOG OUTPUT

The analog output has been calibrated at the factory and should require no other adjustment. If, for some reason, it is found necessary or desirable to readjust this output, the procedure listed below may be used. In order to calibrate the analog output, it is first necessary to enter the Calibration mode by gaining access to the calibration switch. Refer to the Setup and Calibration section of this manual for additional information.

The following questions in the "dAC" section apply only if the board is installed.

dAC (dAC?) – Digital to Analog Converter

With dAC? displayed, press the **ENTER** key. The display will change to show Lo=.

Lo=

Press the **ENTER** key to show the stored value. This is the value, in weight, which outputs zero volts (or 4 mA) from the "dAC". All weight below this target will output zero volts (or 4 mA). If the setting is acceptable, press the **ENTER** key again to save it. Otherwise, using the numeric keys enter the desired weight value, then press the **ENTER** key to save it. The **NET/GROSS** key will change the weight sign. For example, to input -1000 as the weight value, press 1 0 0 0 **NET**. Allowable values are: -99999 to 999999.

Hi=

Press the **ENTER** key to show the stored value. This is the value, in weight, which outputs the maximum selected voltage and current (see oUt=). All weights above this value will output maximum volts from the "dAC". If the setting is acceptable, press the **ENTER** key again to save it. Otherwise, using the numeric keys enter the desired weight value, then press the **ENTER** key to save it. This weight must be a positive value, up to capacity of scale, and above the Lo= value. Allowable values are: 1 to 999999.

oUt=

Press the **ENTER** key to show the stored value. This is the maximum output value in volts (00.01 to 10.00). All weight values equal to or greater than "Hi=" will output this value. Note, that if the scale goes OCAP (over capacity), this value is used also. If the setting is acceptable, press the **ENTER** key again to save it. Otherwise, using the numeric keys enter the desired, then press the **ENTER** key to save it. Allowable values are: 00.01 to 10.00.

NOTE! If the 4 to 20 mA current output is to be used, set "oUt=" to: $10 \times \frac{(\text{max current} - 4)}{16}$

$$\text{Current} = \frac{\text{"oUt="}}{10} \times 16 + 4 \text{ (mA)} \quad (\text{Can not be greater than 20 mA})$$

Adj Hi

This sets the "dAC" output to "oUt=" level for adjusting the level. Adjustment potentiometers "pots" (10V and 20 mA) on the option board are used.

- Adjust the 10V pot for the maximum voltage output entered for "oUt=".
- If the 4 to 20 mA current output is to be used, adjust the 20mA pot for the calculated maximum current.

Press the **ENTER** key to proceed to "Adj Lo", or the **ASTERISK** key to return to the previous prompt.

Adj Lo

This sets the "dAC" output to zero for adjusting the level. Adjustment "pots" (10V and 4 mA) on the option board are used.

- There is no adjustment for zero volts out.
- If the 4 to 20 mA current output is to be used, adjust the 4mA pot for the low (4 mA) current output.

Press the **ASTERISK** key to return to "Adj Hi", or the **ENTER** key to return to the SEtUP prompt



NOTE! Cycling between "Adj Hi" and "Adj Lo" is necessary when adjusting the current out. This must be repeated until no adjustment is necessary.

CALIBRATION of the ANALOG OUTPUT, Cont.

RE-INSTALLING THE REAR PANEL

After all terminations have been made, remove the excess cable from the instrument enclosure and securely tighten each of the cable gland connectors. Do not over-tighten these connectors but make certain they are snug. **DO NOT USE TOOLS!** Finger tighten only! Insure any unused gland connectors are plugged.

Make certain no cables or wires are exposed between the main housing and rear panel then place the rear panel onto the main housing. Secure with the 12 acorn nuts removed earlier.

NOTE! Follow a diagonal pattern when tightening the acorn nuts.

EUROPEAN DECLARATION OF CONFORMITY

Manufacturer: Cardinal Scale Manufacturing Company
PO Box 151
203 East Daugherty
Webb City, Missouri 64870 USA

Telephone No. 417 673 4631
Fax No. 417 673 5001

Product: Non-automatic Weight Indicating Instrument
Model Numbers 200, 205, 210 and 220
Serial Number EXXXYY-ZZZ
where XXX = day of year
YY = last two digits of year
ZZZ = sequential number

The undersigned hereby declares, on behalf of Cardinal Scale Manufacturing Company of Webb City, Missouri, that the above-referenced product, to which this declaration relates, is in conformity with the provisions of:

European Standard EN 45501: 1992 and equivalent International
Recommendation OIML R76, edition 1992
EU Type Approval Certificate Number DK 0199.47
Report No. DANAK-195612

Council Directive 73/23/EEC (19 February, 1993) Low Voltage Directive
as amended by Council Directive 93/68/EEC (22 July, 1993)

Council Directive 90/384/EEC (20 June, 1990) on the Harmonization
Of the Laws of Member States relating to non-automatic weighing
Systems as amended by:
Council Directive 93/68/EEC (22 July, 1993)
Report No. DANAK-195728

European Standard EN50082: 1995 for radiated emissions and
European Standard EN50082-2: 1995 Class B for EMC immunity.

The Technical Construction File required by this Directive is maintained at the corporate headquarters of Cardinal Scale Manufacturing Company, 203 East Daugherty, Webb City, Missouri.

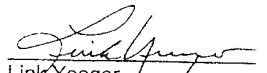
Link Yeager
Director, Quality Assurance

PART IDENTIFICATION

(Rear Enclosure Sub Assembly)

ITEM NO.	QTY.	PART NUMBER	DESCRIPTION
1	8	6013-0039	HEX NUT #6-32
2	4	6013-0245	HEX NUT #4-40
3	2	6021-0654	SCW PAN HEAD #6-32 x .250 PDMS
4	1	6021-1108	SCW FILLISTER MACHINE-SCW #10-32 x .375 S.S.
5	4	6024-0108	WASHER LOCK INT. TOOTH #4 S.S.
6	1	6024-1081	WASHER FLAT #10 NEOPRENE BACKING S.S.
7	4	6540-1104	PLUG, HOLE 0.173-.240 RED POLYETH
8	5	6610-2248	GLAND CONNECTOR
9	1	6610-5007	CABLE CLIP
10	10	6680-0004	WASHER LOCK INT. TOOTH #6 Z/P
11	4	6680-0138	SPACER #6 x .187 NYLON
12	1	6680-0200	POP RIVET
13	2	6680-0203	SPACER (PCB) #6-32 x .500
14	1	6800-1033	POWER SUPPLY BOARD
15	2	6980-0014	WIRE TIE 4" BLACK
16	1	6980-1030	POWER CORD 18/3 SVT CEE 6.3 FT
17	1	8200-B019-08	BRACKET: CALIBRATION SWITCH
18	1	8200-B104-08	LABEL: 205/210 TERM. BLOCK
19	1	8200-B204-0A	CABLE: 205/210 POWER SUPPLY OUTPUT
20	1	8200-B205-0A	CABLE: 205/210 BATTERY CABLE
21	1	8200-B212-0A	CABLE: GND
22	1	8200-B215-0A	CABLE: AC POWER W/FILTER 205/210 DWI
23	1	8200-C012-08	BRACKET, BATTERY HOLDER
24	1	8200-C016-0A	WELDMENT: ENCLOSURE REAR
25	1	8200-C018-08	POWER SUPPLY COVER
26	1	8510-C346-0I	LABEL - HIGH VOLTAGE
27	1	8512-B350-0A	WIRE: 18GA, GRN, 5.0, #8RT/TINNED
28	1	8526-B222-0A	BATTERY POWER BOARD
29	1	8526-B232-08	SPRING, BATTERY COVER
30	1	8539-B254-0A	ASSEMBLY: CABLE, CALIBRATION SWITCH

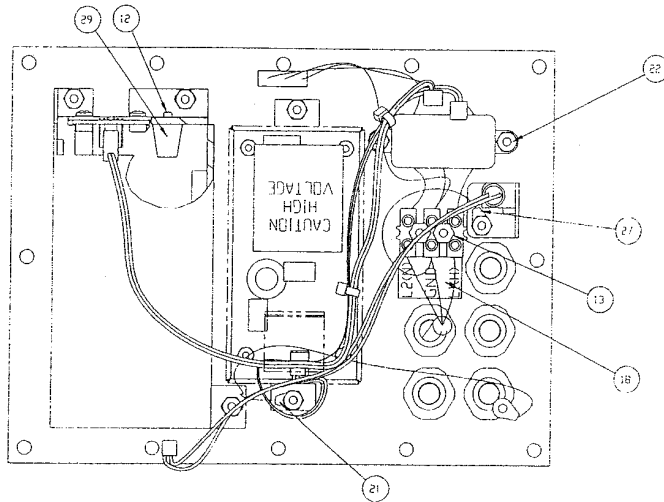

PART IDENTIFICATION

(Rear Enclosure Sub Assembly)

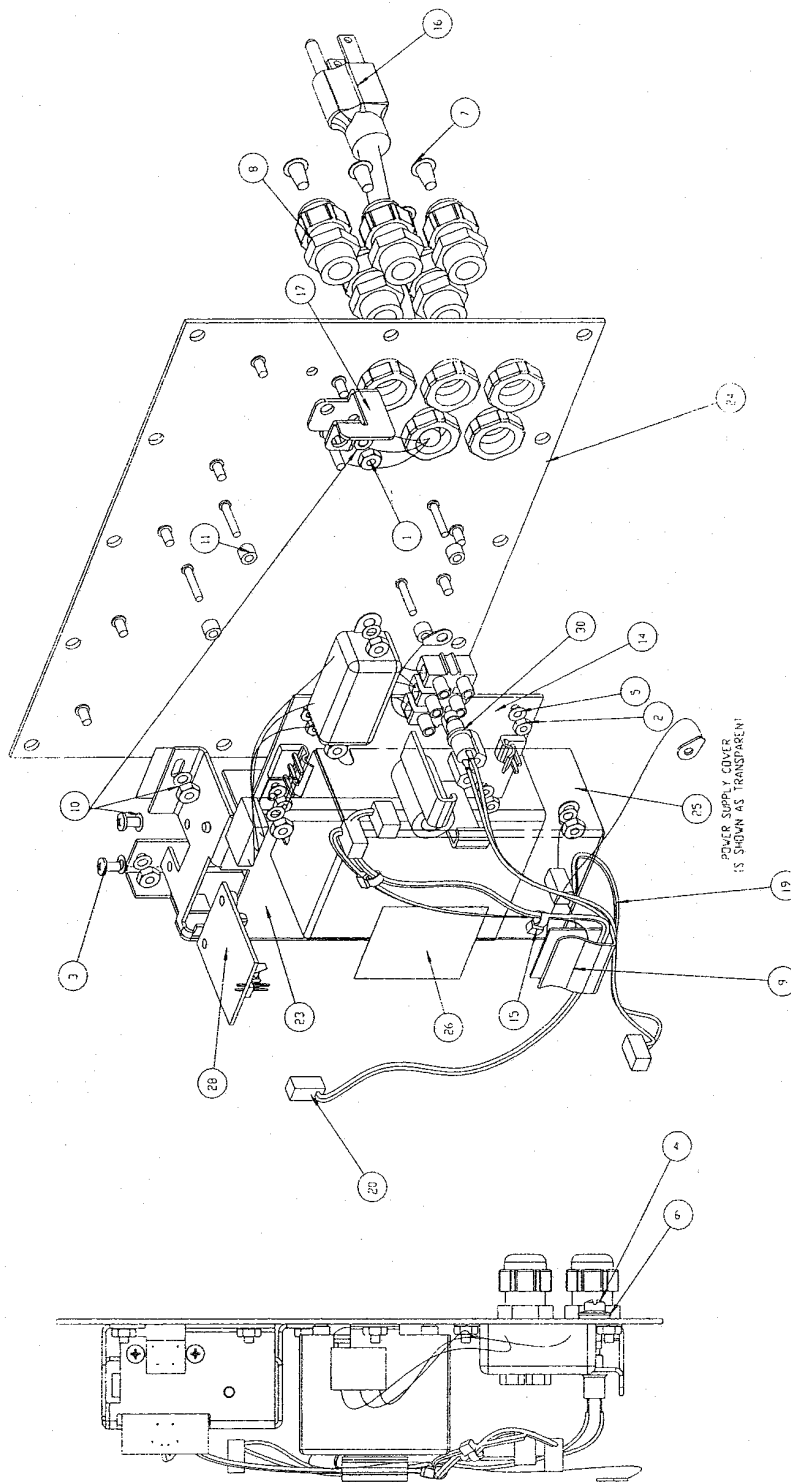

PART IDENTIFICATION

(Front Enclosure Sub Assembly)

ITEM NO.	QTY.	QTY.	PART NUMBER	DESCRIPTION
	205	210		
1	14	14	6013-0039	NUT HEX #6-32
2	1	1	6013-0297	NUT 10-32 HEX
3	3	3	6013-0433	NUT HEX #10-32 ACORN S.S.
4	1	1	6021-0623	SCW PAN HEAD #6-32 x .750 PDMS
5	10	10	6024-1078	WASHER FLAT #6 NEOPRENE BACKING S.S.
6	1	1	6560-0064	DESSICCANT 1 x 1 BAG
7	1	1	6610-5002	GROUND LUG
8	3	3	6610-5007	CABLE CLIP
9	4	4	6680-0004	WASHER LOCK INT. TOOTH #6 Z/P
10	4	4	6680-1049	SPACER (PCB) #6 x .438
11	1	1	6710-1017	TAPE DBL SIDED 1.0 WIDE 45 MIL THK.
12	1	1	8200-B014-08	GASKET FOR 210 ENCLOSURE
13	1	1	8200-B020-08	COVER, BATTERY
14	1	1	8200-B021-08	GASKET: BATTERY DOOR
15	1	1	8200-C015-0A	WELDMENT: BEZEL FOR 210
16	1	1	8200-C017-0A	WELDMENT: ENCLOSURE, FRONT
17			8200-C201-0A	DAC PCB (OPTIONAL)
18	1		8200-D100-08	KEYPAD: 205 DWI
19	1		8200-D201-0A	PC BD, ASSY. 205 MAIN
20		1	8200-D201-1A	PC BD, ASSY. 210 MAIN
21		1	8200-D202-08	KEYPAD: 210 DWI

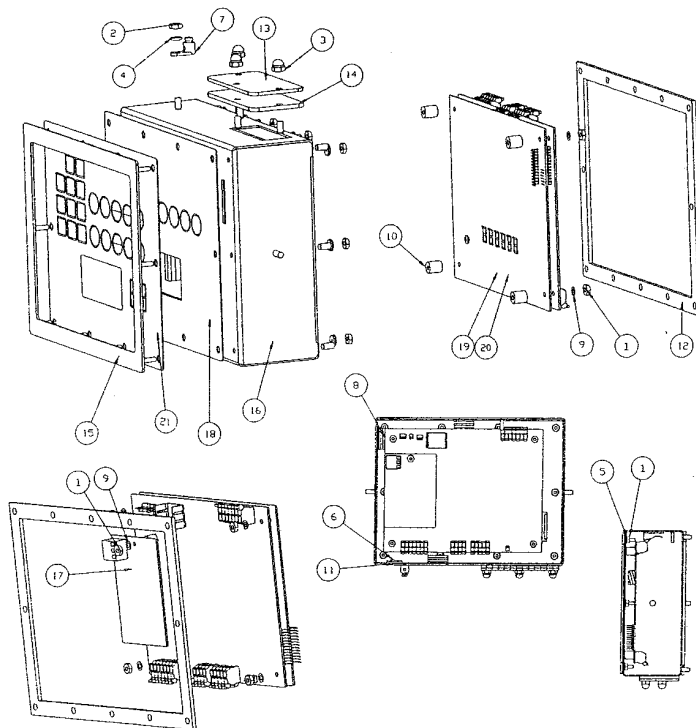

PART IDENTIFICATION

(Final Assembly)

ITEM NO.	QTY.	QTY.	PART NUMBER	DESCRIPTION
	205	210		
1	1	1	593GR986	SERIAL TAG ASSEMBLY
2	11	11	6013-0433	NUT HEX #10-32 ACORN S.S.
3	1	1	6650-0087	LABEL: MADE IN THE USA
4	1	1	8200-B026-08	NUT HEX #10-32 ACORN S.S. DRILLED
5	1	1	8200-D207-0A	SUB ASSEMBLY: REAR ENCLOSURE
6		1	8200-D208-0A	SUB ASSEMBLY: FRONT
8	1		8200-D208-1A	SUB ASSEMBLY: FRONT 205

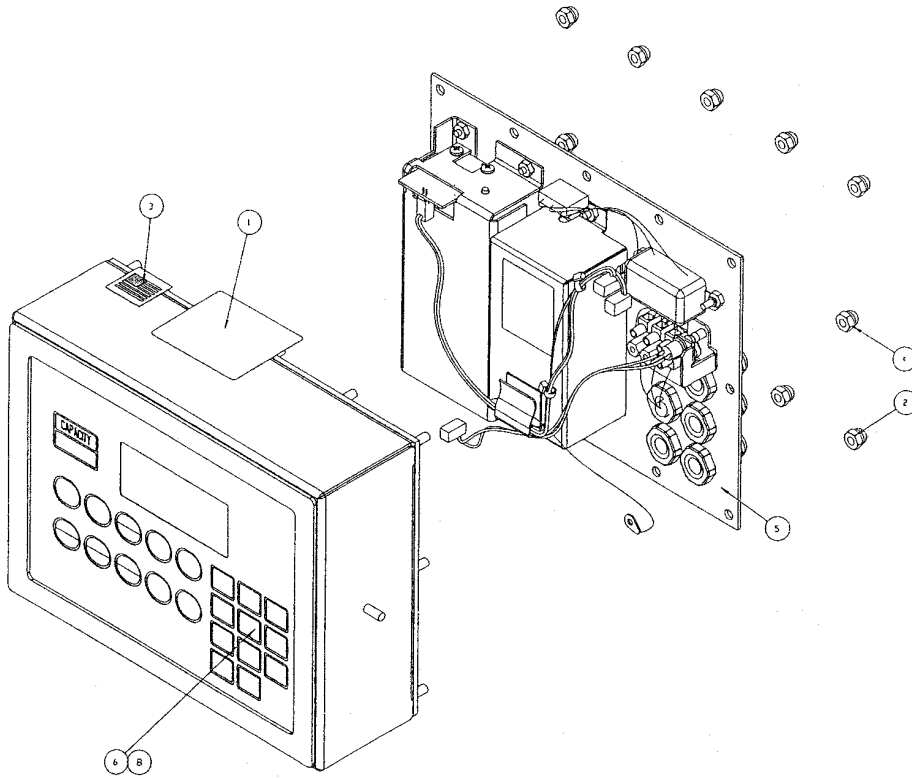





INTRODUCTION

Thank you for purchasing a Honda engine. We want to help you to get the best results from your new engine and to operate it safely. This manual contains information on how to do that; please read it carefully before operating the engine. If a problem should arise, or if you have any questions about your engine, consult an authorized Honda servicing dealer.

All information in this publication is based on the latest product information available at the time of printing. Honda Motor Co., Ltd. reserves the right to make changes at any time without notice and without incurring any obligation. No part of this publication may be reproduced without written permission.

This manual should be considered a permanent part of the engine and should remain with the engine if resold.

Review the instructions provided with the equipment powered by this engine for any additional information regarding engine startup, shutdown, operation, adjustments or any special maintenance instructions.

United States, Puerto Rico, and U.S. Virgin Islands:
We suggest you read the warranty policy to fully understand its coverage and your responsibilities of ownership. The warranty policy is a separate document that should have been given to you by your dealer.

SAFETY MESSAGES

Your safety and the safety of others are very important. We have provided important safety messages in this manual and on the engine. Please read these messages carefully.

A safety message alerts you to potential hazards that could hurt you or others. Each safety message is preceded by a safety alert symbol  and one of three words, DANGER, WARNING, or CAUTION.

These signal words mean:

 **DANGER** You WILL be KILLED or SERIOUSLY HURT if you don't follow instructions.

 **WARNING** You CAN be KILLED or SERIOUSLY HURT if you don't follow instructions.

 **CAUTION** You CAN be HURT if you don't follow instructions.

Each message tells you what the hazard is, what can happen, and what you can do to avoid or reduce injury.

DAMAGE PREVENTION MESSAGES

You will also see other important messages that are preceded by the word NOTICE.

This word means:

 **NOTICE** Your engine or other property can be damaged if you don't follow instructions.

The purpose of these messages is to help prevent damage to your engine, other property, or the environment.

© 2008 Honda Motor Co., Ltd. — All Rights Reserved

GX240UT1-GX270UT-GX340UT1-GX390UT1-GX240RT1-GX270RT-GX340RT1-GX390RT1

37Z5K604

00X37-Z5K-6040

HONDA

OWNER'S MANUAL

MANUEL DE L'UTILISATEUR

MANUAL DEL PROPIETARIO

ENGLISH

GX240 · GX270 · GX340 · GX390

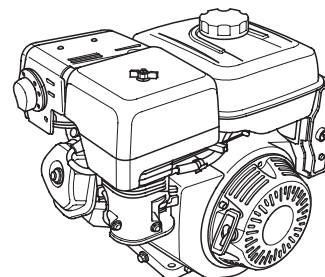

FRANÇAIS

ESPAÑOL

WARNING:

The engine exhaust from this product contains chemicals known to the State of California to cause cancer, birth defects or other reproductive harm.

CONTENTS

INTRODUCTION.....1	SEDIMENT CUP.....12
SAFETY MESSAGES.....1	SPARK PLUG.....12
SAFETY INFORMATION.....2	SPARK ARRESTER.....13
SAFETY LABEL LOCATION.....2	IDLE SPEED.....13
COMPONENT & CONTROL LOCATION.....2	HELPFUL TIPS & SUGGESTIONS.....13
FEATURES.....3	STORING YOUR ENGINE.....13
BEFORE OPERATION CHECKS.....3	TRANSPORTING.....14
OPERATION.....4	TAKING CARE OF UNEXPECTED PROBLEMS.....15
SAFE OPERATING PRECAUTIONS.....4	FUSE REPLACEMENT.....15
STARTING THE ENGINE.....4	TECHNICAL INFORMATION...16
STOPPING THE ENGINE.....5	Serial Number Location.....16
SETTING ENGINE SPEED.....6	Battery Connections for Electric Starter.....16
SERVICING YOUR ENGINE.....7	Remote Control Linkage.....16
THE IMPORTANCE OF MAINTENANCE.....7	Carburetor Modifications for High Altitude Operation.....17
MAINTENANCE SAFETY.....7	Emission Control System Information.....17
SAFETY PRECAUTIONS.....7	Air Index.....18
MAINTENANCE SCHEDULE.....7	Specifications.....18
REFUELING.....8	Tuneup Specifications.....19
ENGINE OIL.....8	Quick Reference Information.....19
Recommended Oil.....8	Wiring Diagrams.....19
Oil Level Check.....9	CONSUMER INFORMATION..20
Oil Change.....9	Distributor/Dealer Locator Information.....20
REDUCTION CASE OIL.....9	Customer Service Information.....20
Recommended Oil.....9	
Oil Level Check.....9	
Oil Change.....10	
AIR CLEANER.....10	
Inspection.....10	
Cleaning.....10	



SAFETY INFORMATION

- Understand the operation of all controls and learn how to stop the engine quickly in case of emergency. Make sure the operator receives adequate instruction before operating the equipment.
- Do not allow children to operate the engine. Keep children and pets away from the area of operation.
- Your engine's exhaust contains poisonous carbon monoxide. Do not run the engine without adequate ventilation, and never run the engine indoors.
- The engine and exhaust become very hot during operation. Keep the engine at least 1 meter (3 feet) away from buildings and other equipment during operation. Keep flammable materials away, and do not place anything on the engine while it is running.

SAFETY LABEL LOCATION

This label warns you of potential hazards that can cause serious injury. Read it carefully. If the label comes off or becomes hard to read, contact your Honda dealer for replacement.



The safety label should be located either on the fuel tank, fan cover or packaged loosely with the engine to be applied by the manufacture.

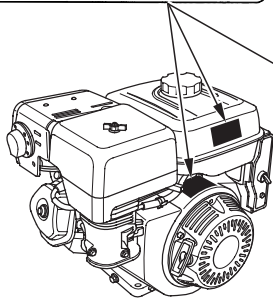

The label is packaged with the engine.

See the manufacturer's instructions provided with the equipment.

For Canada:
French label is packaged with the engine.



Gasoline is highly flammable and explosive. Turn engine off and let cool before refueling.



The engine emits toxic poisonous carbon monoxide gas. Do not run in an enclosed area.



Read Owner's Manual before operation.

COMPONENT & CONTROL LOCATION

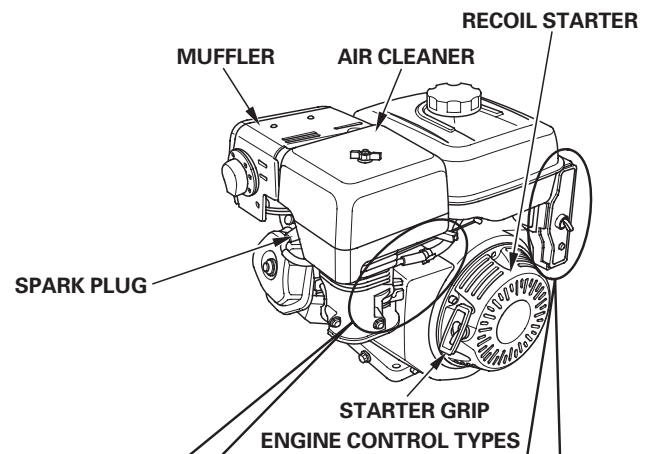
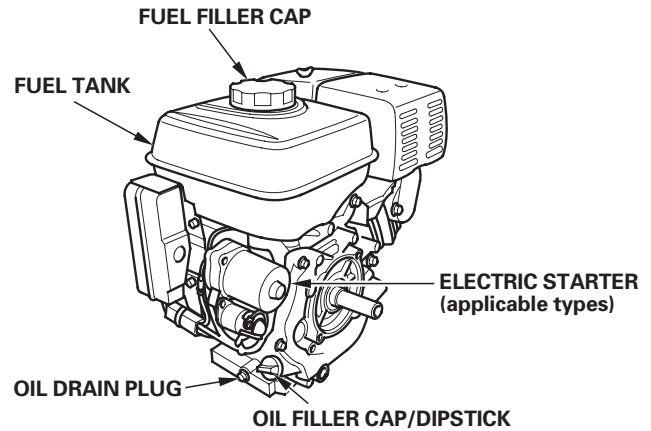

CHOKE LEVER

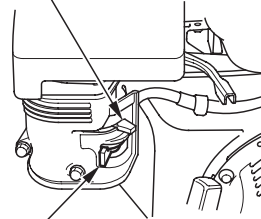

FUEL VALVE LEVER

CHOKE ROD (applicable types)

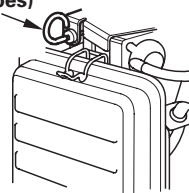

EXCEPT ELECTRIC STARTER TYPES

ENGINE SWITCH

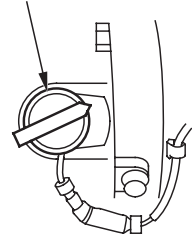

ENGINE SWITCH

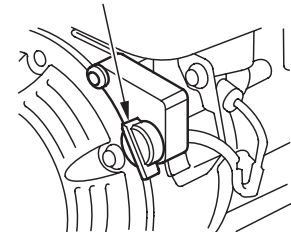

ELECTRIC STARTER TYPES

ENGINE SWITCH

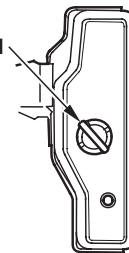

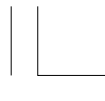

FEATURES

OIL ALERT® SYSTEM (applicable types)

“Oil Alert is a registered trademark in the United States”

The Oil Alert system is designed to prevent engine damage caused by an insufficient amount of oil in the crankcase. Before the oil level in the crankcase can fall below a safe limit, the Oil Alert system will automatically stop the engine (the engine switch will remain in the ON position).

If the engine stops and will not restart, check the engine oil level (see page 9) before troubleshooting in other areas.

CIRCUIT PROTECTOR (applicable types)

The circuit protector protects the battery charging circuit. A short circuit, or a battery connected with reverse polarity, will trip the circuit protector.

The green indicator inside the circuit protector will pop out to show that the circuit protector has switched off. If this occurs, determine the cause of the problem, and correct it before resetting the circuit protector.

Push the circuit protector button to reset.

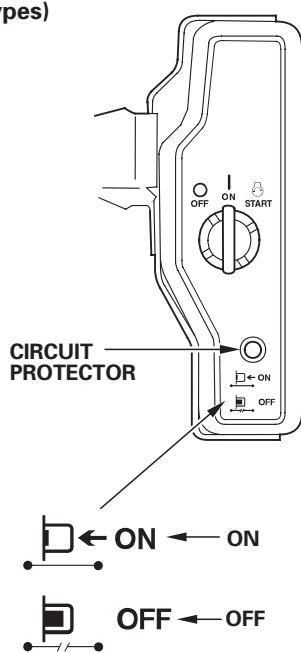

BEFORE OPERATION CHECKS

IS YOUR ENGINE READY TO GO?

For your safety, and to maximize the service life of your equipment, it is very important to take a few moments before you operate the engine to check its condition. Be sure to take care of any problem you find, or have your servicing dealer correct it, before you operate the engine.

⚠ WARNING

Improperly maintaining this engine, or failure to correct a problem before operation, can cause a malfunction in which you can be seriously hurt or killed.

Always perform a pre-operation inspection before each operation, and correct any problem.

Before beginning your pre-operation checks, be sure the engine is level and the engine switch is in the OFF position.

Always check the following items before you start the engine:

Check the General Condition of the Engine

1. Look around and underneath the engine for signs of oil or gasoline leaks.
2. Remove any excessive dirt or debris, especially around the muffler and recoil starter.
3. Look for signs of damage.
4. Check that all shields and covers are in place, and all nuts, bolts, and screws are tightened.

Check the Engine

1. Check the fuel level (see page 8). Starting with a full tank will help to eliminate or reduce operating interruptions for refueling.
2. Check the engine oil level (see page 9). Running the engine with a low oil level can cause engine damage.

The Oil Alert system (applicable types) will automatically stop the engine before the oil level falls below safe limits. However, to avoid the inconvenience of an unexpected shutdown, always check the engine oil level before startup.

3. Check the reduction case oil level on applicable types (see page 9). Oil is essential to reduction case operation and long life.
4. Check the air filter element (see page 10). A dirty air filter element will restrict air flow to the carburetor, reducing engine performance.
5. Check the equipment powered by this engine.

Review the instructions provided with the equipment powered by this engine for any precautions and procedures that should be followed before engine startup.

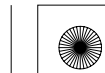



OPERATION

SAFE OPERATING PRECAUTIONS

Before operating the engine for the first time, please review the *SAFETY INFORMATION* section on page 2 and the *BEFORE OPERATION CHECKS* on page 3.

For your safety, do not operate the engine in an enclosed area such as a garage. Your engine's exhaust contains poisonous carbon monoxide gas that can collect rapidly in an enclosed area and cause illness or death.

⚠ WARNING

Exhaust contains poisonous carbon monoxide gas that can build up to dangerous levels in closed areas. Breathing carbon monoxide can cause unconsciousness or death.

Never run the engine in a closed, or even partly closed area where people may be present.

Review the instructions provided with the equipment powered by this engine for any safety precautions that should be observed with engine startup, shutdown or operation.

STARTING THE ENGINE

1. Move the fuel valve lever to the ON position.

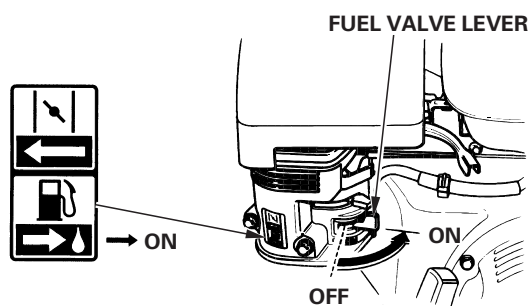

2. To start a cold engine, move the choke lever or choke rod (applicable types) to the CLOSED position.

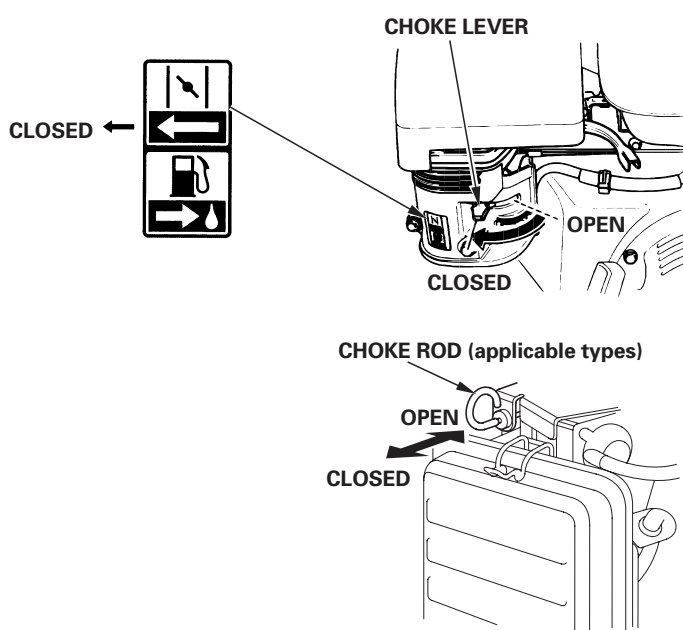

To restart a warm engine, leave the choke lever or choke rod in the OPEN position.

Some engine applications use a remote-mounted choke control rather than the engine-mounted choke lever shown here. Refer to the instructions provided by the equipment manufacturer.

3. Move the throttle lever away from the MIN. position, about 1/3 of the way toward the MAX. position.

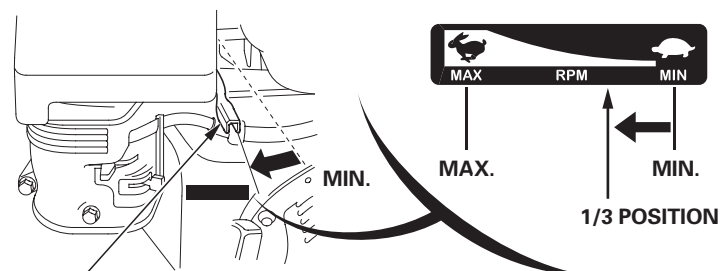

THROTTLE LEVER

Some engine applications use a remote-mounted throttle control rather than the engine-mounted throttle lever shown here. Refer to the instructions provided by the equipment manufacturer.

4. Turn the engine switch to the ON position.

EXCEPT ELECTRIC STARTER TYPES

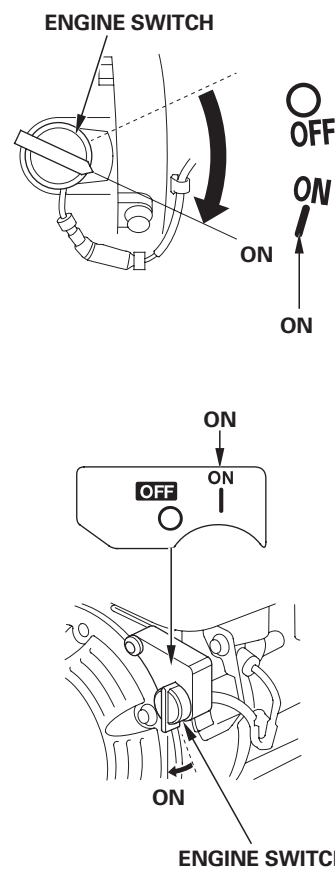

ELECTRIC STARTER TYPES

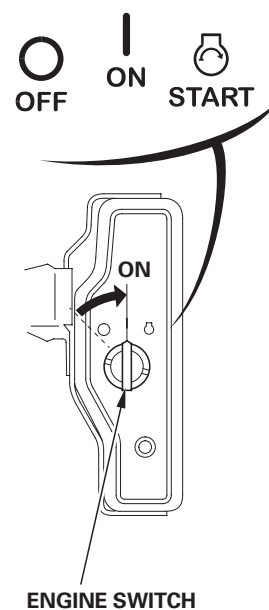

5. Operate the starter.

RECOIL STARTER

Pull the starter grip lightly until you feel resistance, then pull briskly in the direction of the arrow as shown below. Return the starter grip gently.

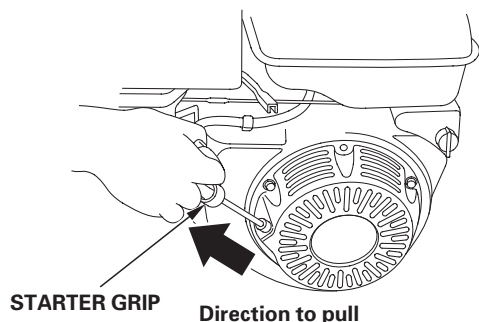

NOTICE

Do not allow the starter grip to snap back against the engine. Return it gently to prevent damage to the starter.

ELECTRIC STARTER (applicable types):

Turn the key to the START position, and hold it there until the engine starts.

If the engine fails to start within 5 seconds, release the key, and wait at least 10 seconds before operating the starter again.

NOTICE

Using the electric starter for more than 5 seconds at a time will overheat the starter motor and can damage it.

When the engine starts, release the key, allowing it to return to the ON position.

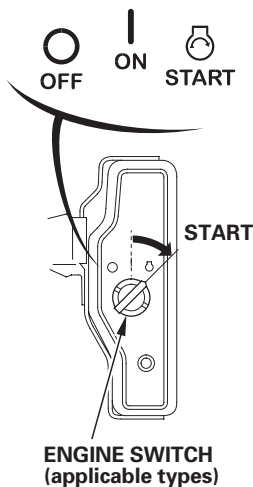

6. If the choke lever or choke rod (applicable types) has been moved to the CLOSED position to start the engine, gradually move it to the OPEN position as the engine warms up.

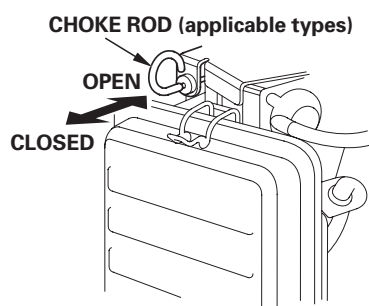
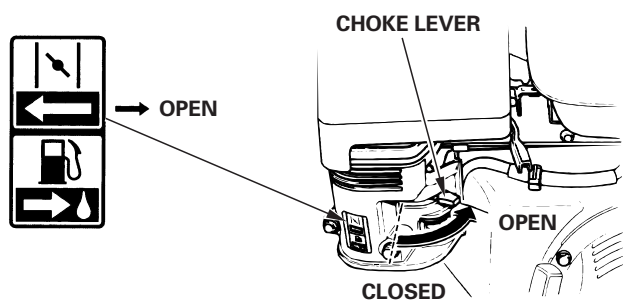

STOPPING THE ENGINE

To stop the engine in an emergency, simply turn the engine switch to the OFF position. Under normal conditions, use the following procedure. Refer to the instructions provided by the equipment manufacturer.

1. Move the throttle lever to the MIN. position.

Some engine applications use a remote-mounted throttle control rather than the engine-mounted throttle lever shown here.

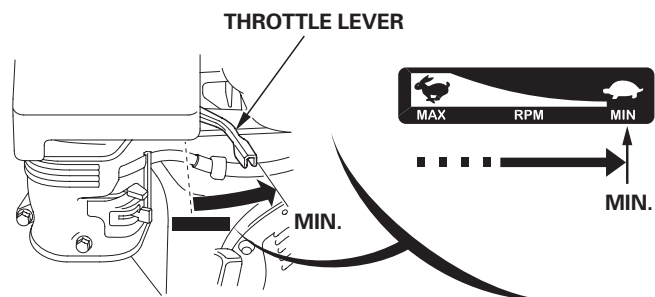

2. Turn the engine switch to the OFF position.

EXCEPT ELECTRIC STARTER TYPES

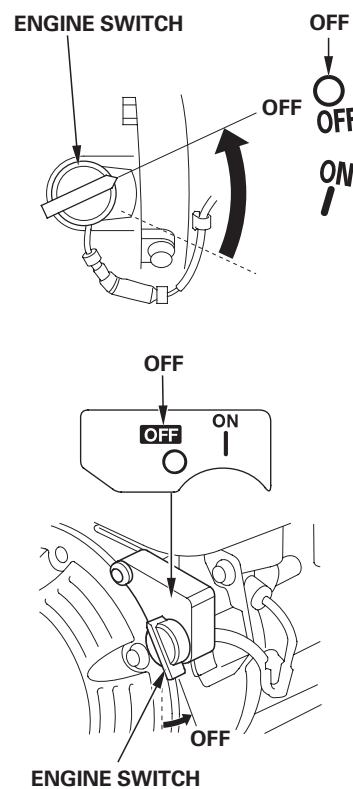

ELECTRIC STARTER TYPES

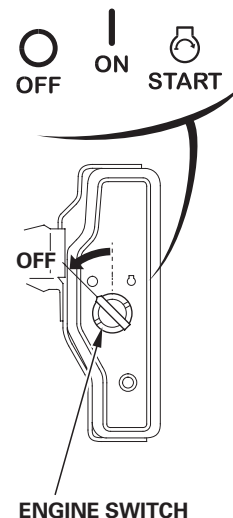

3. Turn the fuel valve lever to the OFF position.

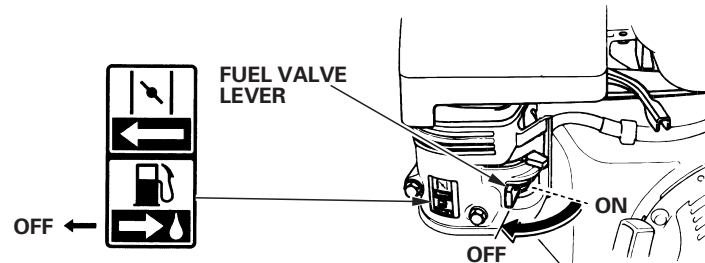

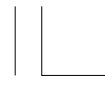

SETTING ENGINE SPEED

Position the throttle lever for the desired engine speed.

Some engine applications use a remote-mounted throttle control rather than the engine-mounted throttle lever shown here. Refer to the instructions provided by the equipment manufacturer.

For engine speed recommendations, refer to the instructions provided with the equipment powered by this engine.

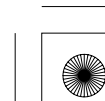
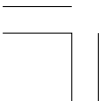
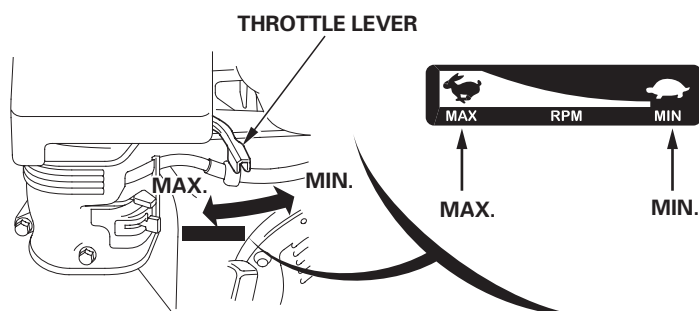



SERVICING YOUR ENGINE

THE IMPORTANCE OF MAINTENANCE

Good maintenance is essential for safe, economical and trouble-free operation. It will also help reduce pollution.

⚠ WARNING

Improper maintenance, or failure to correct a problem before operation, can cause a malfunction in which you can be seriously hurt or killed.

Always follow the inspection and maintenance recommendations and schedules in this owner's manual.

To help you properly care for your engine, the following pages include a maintenance schedule, routine inspection procedures, and simple maintenance procedures using basic hand tools. Other service tasks that are more difficult, or require special tools, are best handled by professionals and are normally performed by a Honda technician or other qualified mechanic.

The maintenance schedule applies to normal operating conditions. If you operate your engine under severe conditions, such as sustained high-load or high-temperature operation, or use in unusually wet or dusty conditions, consult your servicing dealer for recommendations applicable to your individual needs and use.

Maintenance, replacement, or repair of the emission control devices and systems may be performed by any engine repair establishment or individual, using parts that are "certified" to EPA standards.

MAINTENANCE SAFETY

Some of the most important safety precautions follow. However, we cannot warn you of every conceivable hazard that can arise in performing maintenance. Only you can decide whether or not you should perform a given task.

⚠ WARNING

Failure to properly follow maintenance instructions and precautions can cause you to be seriously hurt or killed.

Always follow the procedures and precautions in this owner's manual.

SAFETY PRECAUTIONS

- Make sure the engine is off before you begin any maintenance or repairs. This will eliminate several potential hazards:
 - **Carbon monoxide poisoning from engine exhaust.**
Be sure there is adequate ventilation whenever you operate the engine.
 - **Burns from hot parts.**
Let the engine and exhaust system cool before touching.
 - **Injury from moving parts.**
Do not run the engine unless instructed to do so.
- Read the instructions before you begin, and make sure you have the tools and skills required.
- To reduce the possibility of fire or explosion, be careful when working around gasoline. Use only a non-flammable solvent, not gasoline, to clean parts. Keep cigarettes, sparks and flames away from all fuel related parts.

Remember that an authorized Honda servicing dealer knows your engine best and is fully equipped to maintain and repair it. To ensure the best quality and reliability, use only new Honda Genuine parts or their equivalents for repair and replacement.

MAINTENANCE SCHEDULE

REGULAR SERVICE PERIOD (3) Perform at every indicated month or operating hour interval, whichever comes first.	Each Use	First Month or 20 Hrs	Every 3 Months or 50 Hrs	Every 6 Months or 100 Hrs	Every Year or 300 Hrs	Refer to Page
ITEM						
Engine oil	Check level	○				9
	Change		○	○		9
Reduction case oil (applicable types)	Check level	○				9
	Change		○	○		10
Air cleaner	Check	○				10
	Clean		○ (1)	○ * (1)		10 – 11
	Replace				○ * *	
Sediment cup	Clean			○		12
Spark plug	Check-adjust			○		12
	Replace				○	
Spark arrester (applicable types)	Clean			○		13
Idle speed	Check-adjust				○ (2)	13
Valve clearance	Check-adjust				○ (2)	Shop manual
Combustion chamber	Clean	After every 500 Hrs. (2)				Shop manual
Fuel tank & filter	Clean			○ (2)		Shop manual
Fuel tube	Check	Every 2 years (Replace if necessary) (2)				Shop manual

- * • Internal vent carburetor with dual element type only.
- Cyclone type every 6 months or 150 hours.

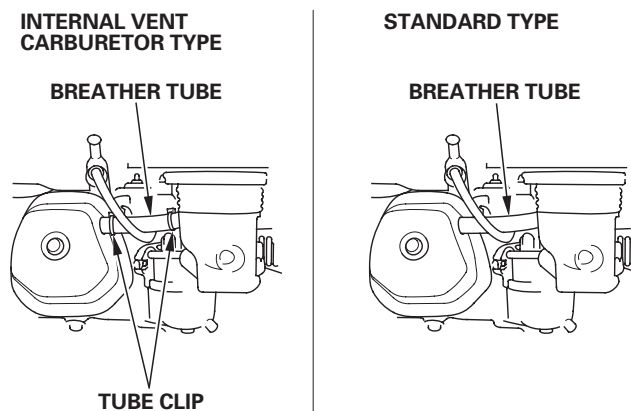

- * * • Replace paper element type only.
- Cyclone type every 2 years or 600 hours.

- (1) Service more frequently when used in dusty areas.
- (2) These items should be serviced by your Honda servicing dealer, unless you have the proper tools and are mechanically proficient. Refer to the Honda shop manual for service procedures.
- (3) For commercial use, log hours of operation to determine proper maintenance intervals.

Failure to follow this maintenance schedule could result in non-warrantable failures.



REFUELING

Recommended Fuel

Unleaded gasoline	
U.S.	Pump octane rating 86 or higher
Except U.S.	Research octane rating 91 or higher Pump octane rating 86 or higher

This engine is certified to operate on unleaded gasoline with a pump octane rating of 86 or higher (a research octane rating of 91 or higher).

Refuel in a well-ventilated area with the engine stopped. If the engine has been running, allow it to cool first. Never refuel the engine inside a building where gasoline fumes may reach flames or sparks.

You may use unleaded gasoline containing no more than 10% ethanol (E10) or 5% methanol by volume. In addition, methanol must contain cosolvents and corrosion inhibitors. Use of fuels with content of ethanol or methanol greater than shown above may cause starting and/or performance problems. It may also damage metal, rubber, and plastic parts of the fuel system. Engine damage or performance problems that result from using a fuel with percentages of ethanol or methanol greater than shown above are not covered under warranty.

If your equipment will be used on an infrequent or intermittent basis, please refer to the fuel section of the HELPFUL TIPS & SUGGESTIONS chapter (see page 13) for additional information regarding fuel deterioration.

⚠ WARNING

Gasoline is highly flammable and explosive, and you can be burned or seriously injured when refueling.

- Stop engine and keep heat, sparks, and flame away.
- Refuel only outdoors.
- Wipe up spills immediately.

NOTICE

Fuel can damage paint and some types of plastic. Be careful not to spill fuel when filling your fuel tank. Damage caused by spilled fuel is not covered under the Distributor's Limited Warranty.

Never use stale or contaminated gasoline or an oil/gasoline mixture. Avoid getting dirt or water in the fuel tank.

For refueling, refer to the manufacturer's instructions provided with the equipment. See the following for a Honda supplied standard fuel tank refueling instruction.

1. With the engine stopped and on a level surface, remove the fuel filler cap and check the fuel level. Refill the tank if the fuel level is low.

FUEL FILLER CAP

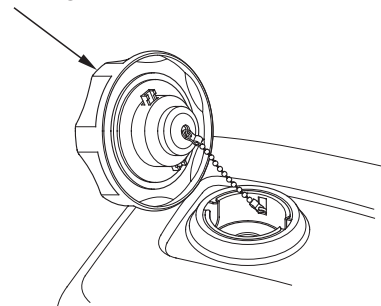

2. Add fuel to the bottom of the maximum fuel level limit of the fuel tank. Do not overfill. Wipe up spilled fuel before starting the engine.

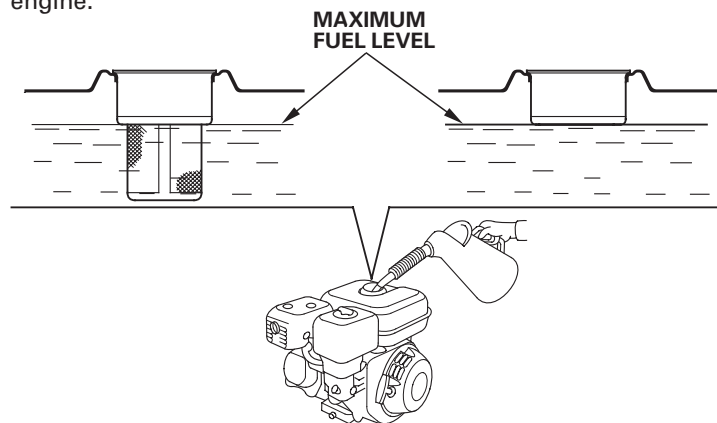

3. Refuel carefully to avoid spilling fuel. Do not fill the fuel tank completely. It may be necessary to lower the fuel level depending on operating conditions. After refueling, tighten the fuel filler cap securely.

Keep gasoline away from appliance pilot lights, barbecues, electric appliances, power tools, etc.

Spilled fuel is not only a fire hazard, it causes environmental damage. Wipe up spills immediately.

ENGINE OIL

Oil is a major factor affecting performance and service life. Use 4-stroke automotive detergent oil.

Recommended Oil

Use 4-stroke motor oil that meets or exceeds the requirements for API service category SJ or later (or equivalent). Always check the API service label on the oil container to be sure it includes the letters SJ or later (or equivalent).

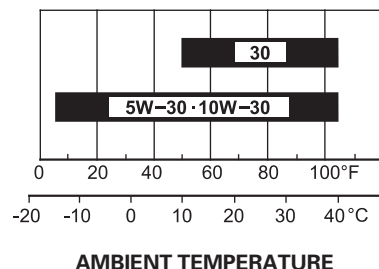

SAE 10W-30 is recommended for general use. Other viscosities shown in the chart may be used when the average temperature in your area is within the indicated range.





Oil Level Check

Check the engine oil level with the engine stopped and in a level position.

1. Remove the oil filler cap/dipstick and wipe it clean.
2. Insert the oil filler cap/dipstick into the oil filler neck as shown, but do not screw it in, then remove it to check the oil level.
3. If the oil level is near or below the lower limit mark on the dipstick, fill with the recommended oil (see page 8) to the upper limit mark (bottom edge of the oil fill hole). Do not overfill.
4. Reinstall the oil filler cap/dipstick.

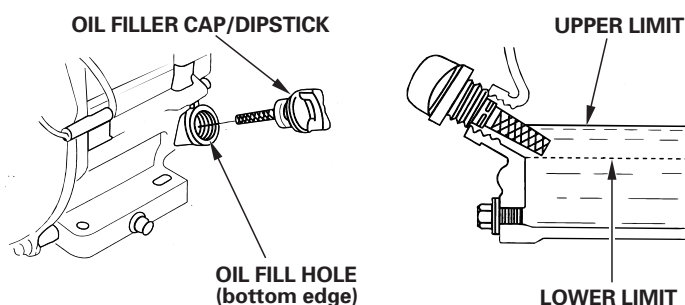

NOTICE

Running the engine with a low oil level can cause engine damage. This type of damage is not covered by the Distributor's Limited Warranty.

The Oil Alert system (applicable types) will automatically stop the engine before the oil level falls below the safe limit. However, to avoid the inconvenience of an unexpected shutdown, always check the engine oil level before startup.

Oil Change

Drain the used oil when the engine is warm. Warm oil drains quickly and completely.

1. Place a suitable container below the engine to catch the used oil, then remove the oil filler cap/dipstick, oil drain plug and washer.
2. Allow the used oil to drain completely, then reinstall the oil drain plug and new washer, and tighten the oil drain plug securely.

Please dispose of used motor oil in a manner that is compatible with the environment. We suggest you take used oil in a sealed container to your local recycling center or service station for reclamation. Do not throw it in the trash, pour it on the ground, or pour it down a drain.

3. With the engine in a level position, fill with the recommended oil (see page 8) to the upper limit mark (bottom edge of the oil fill hole) on the dipstick.

NOTICE

Running the engine with a low oil level can cause engine damage. This type of damage is not covered by the Distributor's Limited Warranty.

The Oil Alert system (applicable types) will automatically stop the engine before the oil level falls below the safe limit. However, to avoid the inconvenience of an unexpected shutdown, fill to the upper limit, and check the oil level regularly.

4. Install the oil filler cap/dipstick and tighten securely.

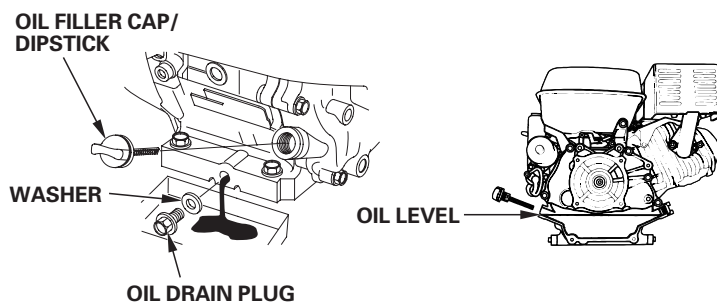

REDUCTION CASE OIL (applicable types)

Recommended Oil

Use the same oil that is recommended for the engine (see page 8).

Oil Level Check

Check the reduction case oil level with the engine stopped and in a level position.

1/2 Reduction Case With Centrifugal Clutch

1. Remove the oil filler cap/dipstick and wipe it clean.
2. Insert and remove the oil filler cap/dipstick without screwing it into the filler hole. Check the oil level shown on the oil filler cap/dipstick.
3. If the oil level is low, add the recommended oil to reach the upper limit mark on the dipstick.
4. Screw in the oil filler cap/dipstick and tighten securely.

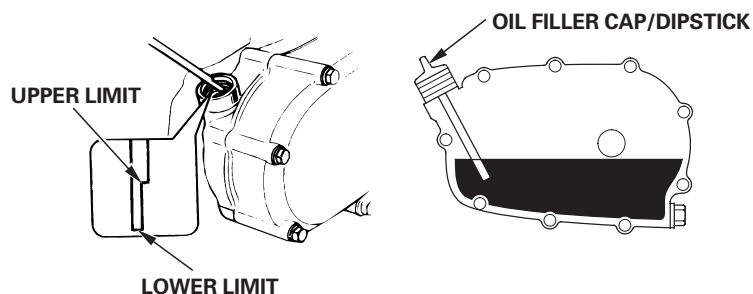



Oil Change

Drain the used oil while the engine is warm. Warm oil drains quickly and completely.

1. Place a suitable container below the reduction case to catch the used oil, then remove the oil filler cap/dipstick, the drain plug and washer.
2. Allow the used oil to drain completely, then reinstall the drain plug and a new washer, and tighten it securely.

Please dispose of used motor oil in a manner that is compatible with the environment. We suggest you take used oil in a sealed container to your local recycling center or service station for reclamation. Do not throw it in the trash or pour it on the ground or pour it down a drain.

3. With the engine in a level position, fill with the recommended oil (see page 8) to the upper limit mark on the dipstick. To check the oil level, insert and remove the dipstick without screwing it into the filler hole.

Reduction case oil capacity: 0.30 L (0.32 US qt, 0.26 Imp qt)

NOTICE

Running the engine with a low reduction case oil level can cause reduction case damage.

4. Screw in the oil filler cap/dipstick and tighten securely.

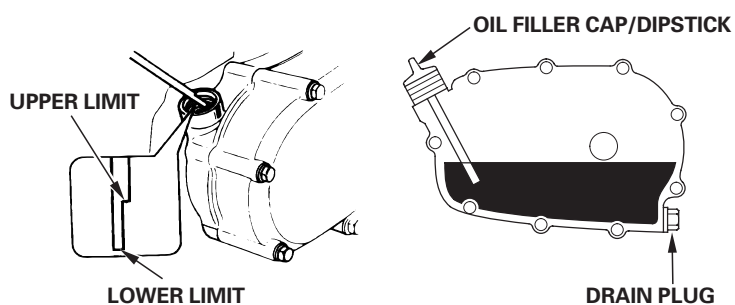

AIR CLEANER

A dirty air cleaner will restrict air flow to the carburetor, reducing engine performance. If you operate the engine in very dusty areas, clean the air filter more often than specified in the MAINTENANCE SCHEDULE (see page 7).

NOTICE

Operating the engine without an air filter, or with a damaged air filter, will allow dirt to enter the engine, causing rapid engine wear. This type of damage is not covered by the Distributor's Limited Warranty.

Inspection

Remove the air cleaner cover and inspect the filter elements. Clean or replace dirty filter elements. Always replace damaged filter elements. If equipped with an oil-bath air cleaner, also check the oil level.

Refer to pages 10 – 11 for instructions that apply to the air cleaner and filter for your engine type.

Cleaning

Dual-Filter Element Types

1. Remove the wing nut from the air cleaner cover, and remove the cover.
2. Remove the wing nut from the air filter, and remove the filter.
3. Remove the foam filter from the paper filter.
4. Inspect both air filter elements, and replace them if they are damaged. Always replace the paper air filter element at the scheduled interval (see page 7).

STANDARD DUAL-FILTER ELEMENT TYPE

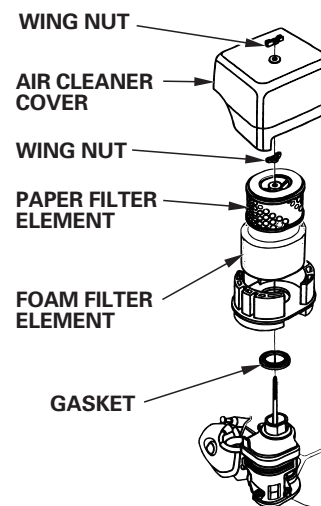

CYCLONE DUAL-FILTER ELEMENT TYPE

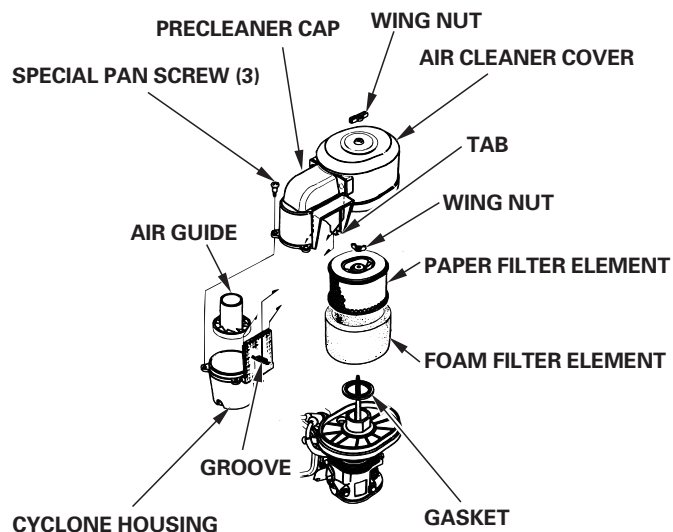



5. Clean the air filter elements if they are to be reused.

Paper air filter element: Tap the filter element several times on a hard surface to remove dirt, or blow compressed air [not exceeding 207 kPa (2.1 kgf/cm², 30 psi)] through the filter element from the inside. Never try to brush off dirt; brushing will force dirt into the fibers.

Foam air filter element: Clean in warm soapy water, rinse, and allow to dry thoroughly. Or clean in non-flammable solvent and allow to dry. Dip the filter element in clean engine oil, then squeeze out all excess oil. The engine will smoke when started if too much oil is left in the foam.

6. CYCLONE TYPE ONLY: Remove the three pan-head screws from the pre-cleaner cap, then remove the cyclone housing and air guide. Wash the parts with water, dry them thoroughly, and reassemble them.

Be sure to install the air guide as shown in the illustration.

Install the cyclone housing so the air intake tab fits into the groove in the pre-cleaner cap.

7. Wipe dirt from the inside of the air cleaner case and cover using a moist rag. Be careful to prevent dirt from entering the air duct that leads to the carburetor.

8. Place the foam air filter element over the paper element, and reinstall the assembled air filter. Be sure the gasket is in place beneath the air filter. Tighten the air filter wing nut securely.

9. Install the air cleaner cover, and tighten the wing nut securely.

Oil Bath & Single-Filter Element Types

1. Remove the wing nut, and remove the air cleaner cap and cover.

2. Remove the air filter element from the cover. Wash the cover and filter element in warm soapy water, rinse, and allow to dry thoroughly. Or clean in non-flammable solvent and allow to dry.

3. Dip the filter element in clean engine oil, then squeeze out all excess oil. The engine will smoke if too much oil is left in the foam.

4. OIL BATH TYPE ONLY: Empty the used oil from the air cleaner case, wash out any accumulated dirt with non-flammable solvent, and dry the case.

5. OIL BATH TYPE ONLY: Fill the air cleaner case to the OIL LEVEL mark with the same oil that is recommended for the engine (see page 8).

Oil capacities:

GX240/GX270: 60 cm³ (2.0 US oz, 2.1 Imp oz)

GX340/GX390: 80 cm³ (2.7 US oz, 2.8 Imp oz)

6. Reassemble the air cleaner, and tighten the wing nut securely.

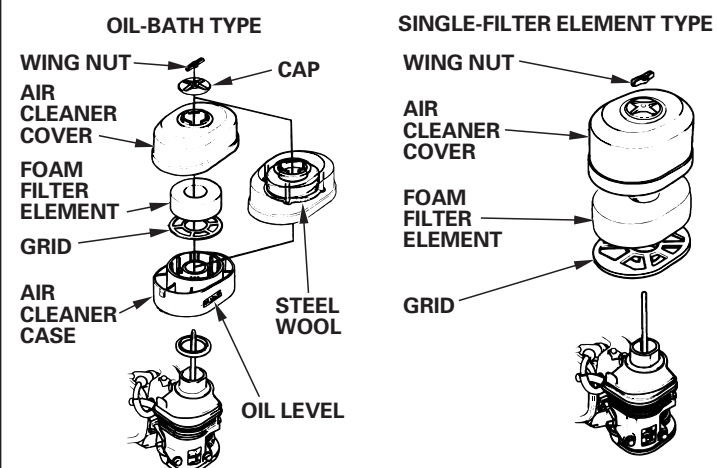

Low Profile Types

1. Unsnap the air cleaner cover clips, remove the air cleaner cover, and remove the air filter element.

2. Wash the element in a solution of household detergent and warm water, then rinse thoroughly, or wash in non-flammable or high flash point solvent. Allow the element to dry thoroughly.

3. Soak the air filter element in clean engine oil and squeeze out the excess oil. The engine will smoke during initial startup if too much oil is left in the element.

4. Reinstall the air filter element and the cover.

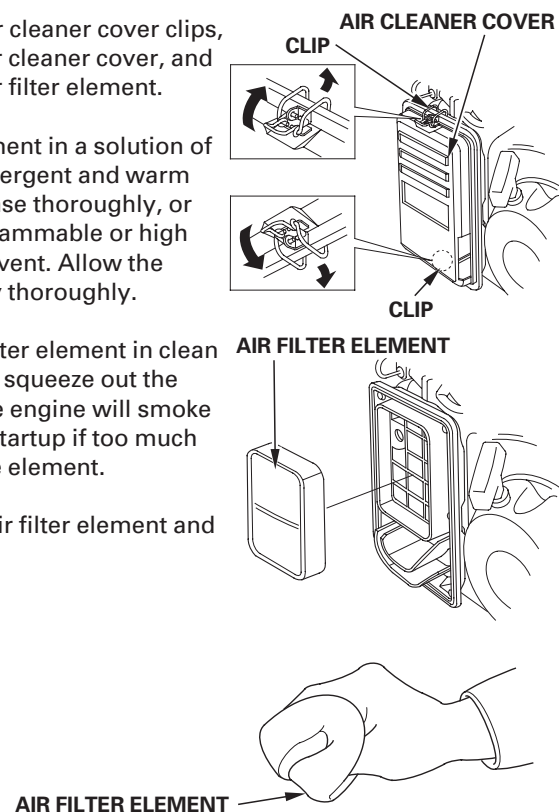

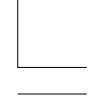

SEDIMENT CUP

Cleaning

⚠ WARNING

Gasoline is highly flammable and explosive, and you can be burned or seriously injured when handling fuel.

- Stop engine and keep heat, sparks, and flame away.
- Handle fuel only outdoors.
- Wipe up spills immediately.

1. Move the fuel valve lever to the OFF position, then remove the sediment cup and O-ring.
2. Wash the sediment cup in non-flammable solvent, and dry it thoroughly.

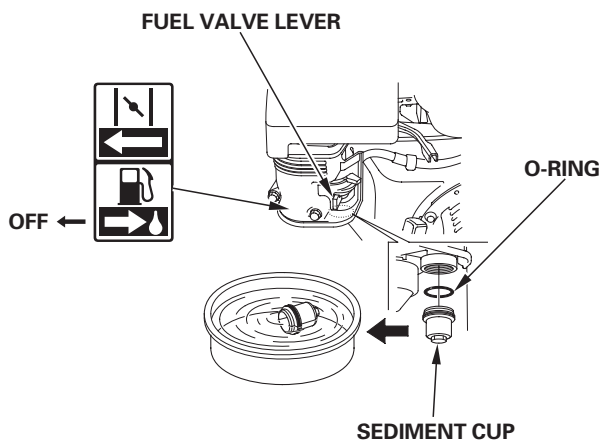

3. Place the O-ring in the fuel valve, and install the sediment cup. Tighten the sediment cup securely.
4. Move the fuel valve lever to the ON position, and check for leaks. Replace the O-ring if there is any leakage.

SPARK PLUG

Recommended Spark Plugs: BPR6ES (NGK)
W20EPR-U (DENSO)

The recommended spark plug has the correct heat range for normal engine operating temperatures.

NOTICE

An incorrect spark plug can cause engine damage.

If the engine has been running, let it cool before servicing the spark plug.

For good performance, the spark plug must be properly gapped and free of deposits.

1. Disconnect the spark plug cap, and remove any dirt from around the spark plug area.
2. Remove the spark plug with a 13/16-inch spark plug wrench.
3. Visually inspect the spark plug. Replace it if damaged or badly fouled, if the sealing washer is in poor condition, or if the electrode is worn.
4. Measure the spark plug electrode gap with a wire-type feeler gauge. Correct the gap, if necessary, by carefully bending the side electrode. The gap should be: 0.7–0.8 mm (0.028–0.031 in)

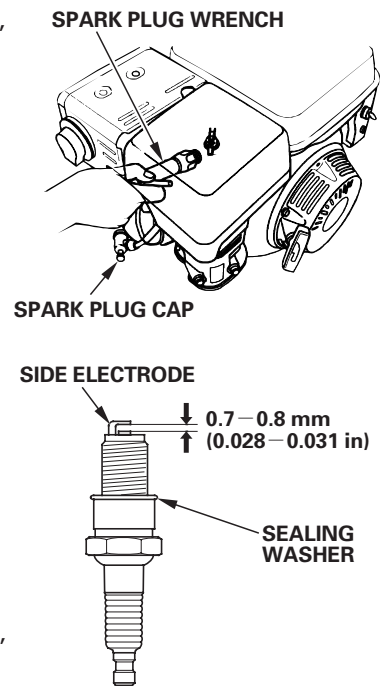

5. Install the spark plug carefully, by hand, to avoid cross-threading.

6. After the spark plug is seated, tighten with a 13/16-inch spark plug wrench to compress the sealing washer.

When installing a new spark plug, tighten 1/2 turn after the spark plug seats to compress the washer.

When reinstalling the original spark plug, tighten 1/8–1/4 turn after the spark plug seats to compress the washer.

NOTICE

A loose spark plug can overheat and damage the engine. Overtightening the spark plug can damage the threads in the cylinder head.

7. Attach the spark plug cap to the spark plug.

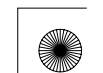



SPARK ARRESTER (applicable types)

The spark arrester may be standard or an optional part, depending on the engine type. In some areas, it is illegal to operate an engine without a spark arrester. Check local laws and regulations. A spark arrester is available from authorized Honda servicing dealers.

The spark arrester must be serviced every 100 hours to keep it functioning as designed.

If the engine has been running, the muffler will be hot. Allow it to cool before servicing the spark arrester.

Spark Arrester Removal

1. Remove the two 8 mm nuts and remove the muffler from the cylinder.
2. Remove the three 4 mm screws from the exhaust deflector, and remove the deflector.
3. Remove the four 5 mm screws from the muffler protector and remove the muffler protector.
4. Remove the 4 mm screw from the spark arrester, and remove the spark arrester from the muffler.

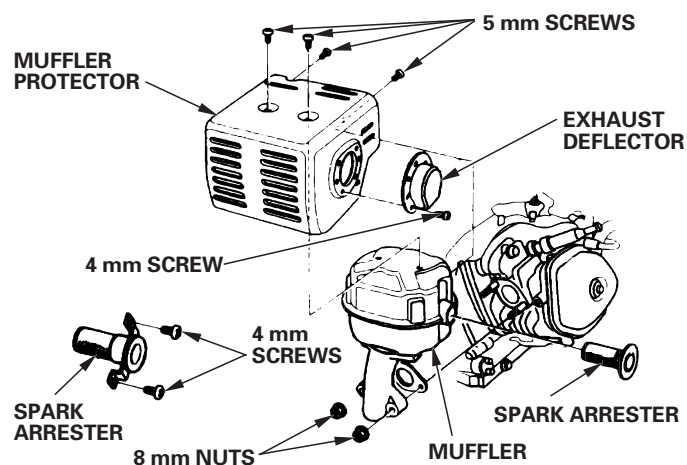

Spark Arrester Cleaning & Inspection

1. Use a brush to remove carbon deposits from the spark arrester screen. Be careful not to damage the screen. Replace the spark arrester if it has breaks or holes.

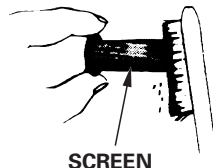

2. Install the spark arrester, muffler protector, exhaust deflector and muffler in the reverse order of disassembly.

IDLE SPEED

Adjustment

1. Start the engine outdoors, and allow it to warm up to operating temperature.
2. Move the throttle lever to its minimum position.
3. Turn the throttle stop screw to obtain the standard idle speed.

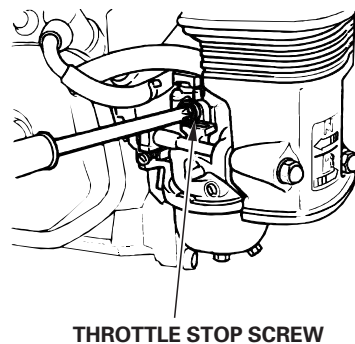

Standard idle speed: 1,400 ± 150 rpm

HELPFUL TIPS & SUGGESTIONS

STORING YOUR ENGINE

Storage Preparation

Proper storage preparation is essential for keeping your engine trouble-free and looking good. The following steps will help to keep rust and corrosion from impairing your engine's function and appearance, and will make the engine easier to start when you use it again.

Cleaning

If the engine has been running, allow it to cool for at least half an hour before cleaning. Clean all exterior surfaces, touch up any damaged paint, and coat other areas that may rust with a light film of oil.

NOTICE

Using a garden hose or pressure washing equipment can force water into the air cleaner or muffler opening. Water in the air cleaner will soak the air filter, and water that passes through the air filter or muffler can enter the cylinder, causing damage.

Fuel

NOTICE

Depending on the region where you operate your equipment, fuel formulations may deteriorate and oxidize rapidly. Fuel deterioration and oxidation can occur in as little as 30 days and may cause damage to the carburetor and/or fuel system. Please check with your servicing dealer for local storage recommendations.

Gasoline will oxidize and deteriorate in storage. Deteriorated gasoline will cause hard starting, and it leaves gum deposits that clog the fuel system. If the gasoline in your engine deteriorates during storage, you may need to have the carburetor and other fuel system components serviced or replaced.

The length of time that gasoline can be left in your fuel tank and carburetor without causing functional problems will vary with such factors as gasoline blend, your storage temperatures, and whether the fuel tank is partially or completely filled. The air in a partially filled fuel tank promotes fuel deterioration. Very warm storage temperatures accelerate fuel deterioration. Fuel deterioration problems may occur within a few months, or even less if the gasoline was not fresh when you filled the fuel tank.

Fuel system damage or engine performance problems resulting from neglected storage preparation are not covered under the *Distributor's Limited Warranty*.

You can extend fuel storage life by adding a gasoline stabilizer that is formulated for that purpose, or you can avoid fuel deterioration problems by draining the fuel tank and carburetor.

Adding a Gasoline Stabilizer to Extend Fuel Storage Life

When adding a gasoline stabilizer, fill the fuel tank with fresh gasoline. If only partially filled, air in the tank will promote fuel deterioration during storage. If you keep a container of gasoline for refueling, be sure that it contains only fresh gasoline.

1. Add gasoline stabilizer following the manufacturer's instructions.
2. After adding a gasoline stabilizer, run the engine outdoors for 10 minutes to be sure that treated gasoline has replaced the untreated gasoline in the carburetor.
3. Stop the engine.



**Draining the Fuel Tank and Carburetor****⚠ WARNING**

Gasoline is highly flammable and explosive, and you can be burned or seriously injured when handling fuel.

- Stop engine and keep heat, sparks, and flame away.
- Handle fuel only outdoors.
- Wipe up spills immediately.

1. Move the fuel valve lever to the OFF positions.
2. Place an approved gasoline container below the carburetor, and use a funnel to avoid spilling fuel.
3. Remove the carburetor drain bolt and gasket. Remove the sediment cup and O-ring, then move the fuel valve lever to the ON position.

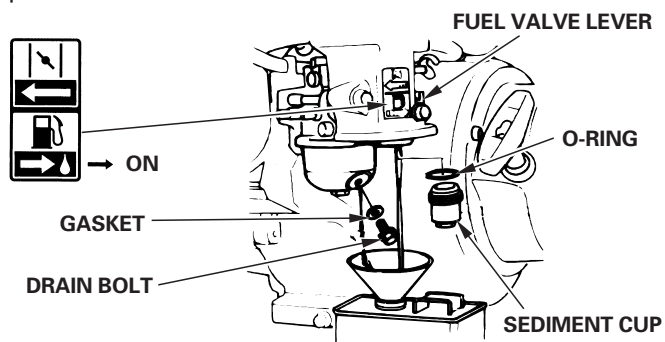

4. After all the fuel has drained into the container, reinstall the drain bolt, gasket, sediment cup and O-ring. Tighten the drain bolt and sediment cup securely.

Engine Oil

1. Change the engine oil (see page 9).
2. Remove the spark plug (see page 12).
3. Pour a teaspoon 5 – 10 cm³ (5 – 10 cc) of clean engine oil into the cylinder.
4. Pull the starter grip several times to distribute the oil in the cylinder.
5. Reinstall the spark plug.
6. Pull the starter grip slowly until resistance is felt and the notch on the starter pulley aligns with the hole at the top of the recoil starter cover. This will close the valves so moisture cannot enter the engine cylinder. Return the starter grip gently.

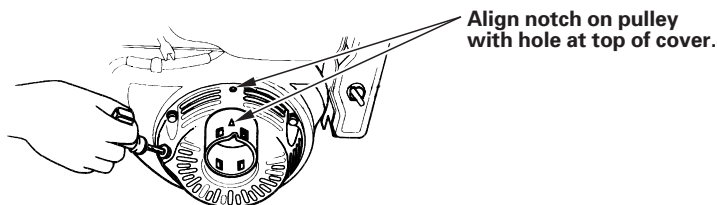
**Storage Precautions**

If your engine will be stored with gasoline in the fuel tank and carburetor, it is important to reduce the hazard of gasoline vapor ignition. Select a well-ventilated storage area away from any appliance that operates with a flame, such as a furnace, water heater, or clothes dryer. Also avoid any area with a spark-producing electric motor, or where power tools are operated.

If possible, avoid storage areas with high humidity, because that promotes rust and corrosion.

Keep the engine level in storage. Tilting can cause fuel or oil leakage.

With the engine and exhaust system cool, cover the engine to keep out dust. A hot engine and exhaust system can ignite or melt some materials. Do not use sheet plastic as a dust cover. A nonporous cover will trap moisture around the engine, promoting rust and corrosion.

If equipped with a battery for electric starter types, recharge the battery once a month while the engine is in storage. This will help to extend the service life of the battery.

Removal from Storage

Check your engine as described in the *BEFORE OPERATION CHECKS* section of this manual (see page 3).

If the fuel was drained during storage preparation, fill the tank with fresh gasoline. If you keep a container of gasoline for refueling, be sure it contains only fresh gasoline. Gasoline oxidizes and deteriorates over time, causing hard starting.

If the cylinder was coated with oil during storage preparation, the engine will smoke briefly at startup. This is normal.

TRANSPORTING

If the engine has been running, allow it to cool for at least 15 minutes before loading the engine-powered equipment on the transport vehicle. A hot engine and exhaust system can burn you and can ignite some materials.

Keep the engine level when transporting to reduce the possibility of fuel leakage. Turn the fuel valve to the OFF position (see page 5).



**TAKING CARE OF UNEXPECTED PROBLEMS**

ENGINE WILL NOT START	Possible Cause	Correction
1. Electric starting (applicable types): Check battery and fuse.	Battery discharged.	Recharge battery.
	Fuse burnt out.	Replace fuse. (p. 15).
2. Check control positions.	Fuel valve OFF.	Move lever to ON position.
	Choke open.	Move lever to CLOSED position unless the engine is warm.
	Engine switch OFF.	Turn engine switch to ON position.
3. Check engine oil level.	Engine oil level low (Oil Alert models).	Fill with the recommended oil to the proper level (p. 9).
4. Check fuel.	Out of fuel.	Refuel (p. 8).
	Bad fuel; engine stored without treating or draining gasoline, or refueled with bad gasoline.	Drain fuel tank and carburetor (p. 14). Refuel with fresh gasoline (p. 8).
5. Remove and inspect spark plug.	Spark plug faulty, fouled, or improperly gapped.	Gap or replace spark plug (p. 12).
	Spark plug wet with fuel (flooded engine).	Dry and reinstall spark plug. Start engine with throttle lever in MAX. position.
6. Take engine to an authorized Honda servicing dealer, or refer to shop manual.	Fuel filter restricted, carburetor malfunction, ignition malfunction, valves stuck, etc.	Replace or repair faulty components as necessary.

ENGINE LACKS POWER	Possible Cause	Correction
1. Check air filter.	Filter element(s) restricted.	Clean or replace filter element(s) (p. 10–11).
2. Check fuel.	Bad fuel; engine stored without treating or draining gasoline, or refueled with bad gasoline.	Drain fuel tank and carburetor (p. 14). Refuel with fresh gasoline (p. 8).
3. Take engine to an authorized Honda servicing dealer, or refer to shop manual.	Fuel filter restricted, carburetor malfunction, ignition malfunction, valves stuck, etc.	Replace or repair faulty components as necessary.

FUSE REPLACEMENT (applicable types)

The electric starter relay circuit and battery charging circuit are protected by a fuse. If the fuse burns out, the electric starter will not operate. The engine can be started manually if the fuse burns out, but running the engine will not charge the battery.

1. Remove the 6 × 12 mm screw from the rear cover of the engine switch box.

2. Remove the fuse cover, then pull out and inspect the fuse.

If the fuse is burnt out, discard the burnt-out fuse. Install a new fuse with the same rating as the one that was removed, and reinstall the cover.

If you have questions regarding the rating of the original fuse, contact your servicing Honda engine dealer.

NOTICE

Never use a fuse with a rating greater than the one originally equipped with the engine. Serious damage to the electrical system or a fire could result.

3. Reinstall the rear cover. Install the 6 × 12 mm screw and tighten it securely.

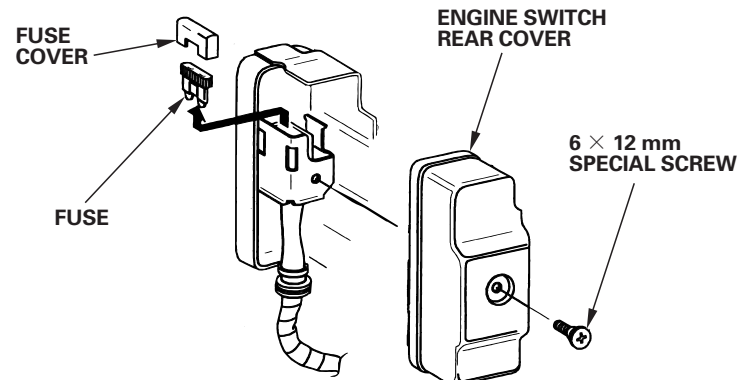

Frequent fuse failure usually indicates a short circuit or an overload in the electrical system. If the fuse burns out frequently, take the engine to a servicing Honda dealer for repair.





TECHNICAL INFORMATION

Serial Number Location

Record the engine serial number in the space below. You will need this information when ordering parts and when making technical or warranty inquiries.

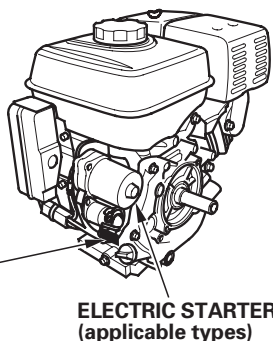

Engine serial number: _____

Engine type: _____

Date Purchased: ____/____/____

Battery Connections for Electric Starter (applicable types)

Recommended Battery

GX240	12 V – 14 Ah ~ 12 V – 30 Ah
GX270	
GX340	12 V – 18 Ah ~ 12 V – 30 Ah
GX390	

Be careful not to connect the battery in reverse polarity, as this will short circuit the battery charging system. Always connect the positive (+) battery cable to the battery terminal before connecting the negative (-) battery cable, so your tools cannot cause a short circuit if they touch a grounded part while tightening the positive (+) battery cable end.

⚠ WARNING

A battery can explode if you do not follow the correct procedure, seriously injuring anyone nearby.

Keep all sparks, open flames, and smoking materials away from the battery.

WARNING: Battery posts, terminals, and related accessories contain lead and lead compounds. **Wash hands after handling.**

1. Connect the battery positive (+) cable to the starter solenoid terminal as shown.
2. Connect the battery negative (-) cable to an engine mounting bolt, frame bolt, or other good engine ground connection.
3. Connect the battery positive (+) cable to the battery positive (+) terminal as shown.
4. Connect the battery negative (-) cable to the battery negative (-) terminal as shown.
5. Coat the terminals and cable ends with grease.

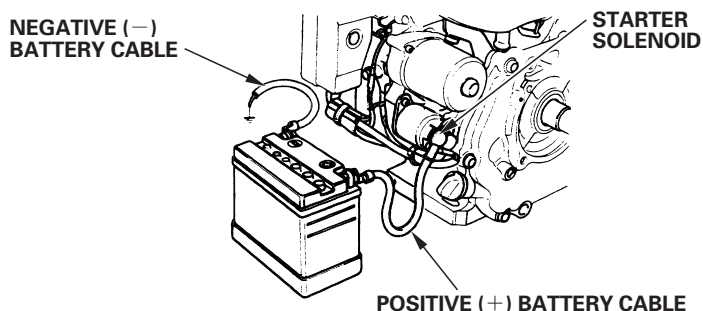

Remote Control Linkage

The throttle and choke control levers are provided with holes for optional cable attachment. The following illustrations show installation examples for a solid wire cable and for a flexible, braided wire cable. If using a flexible, braided wire cable, add a return spring as shown.

It is necessary to loosen the throttle lever friction nut when operating the throttle with a remote-mounted control.

REMOTE THROTTLE LINKAGE

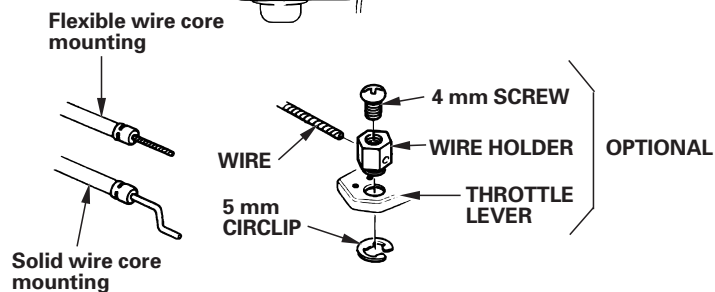
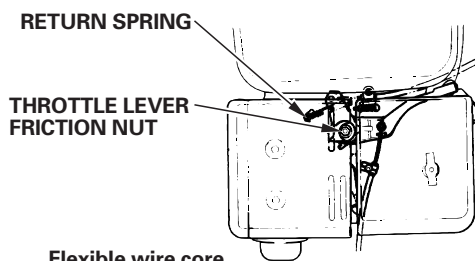

REMOTE CHOKE LINKAGE

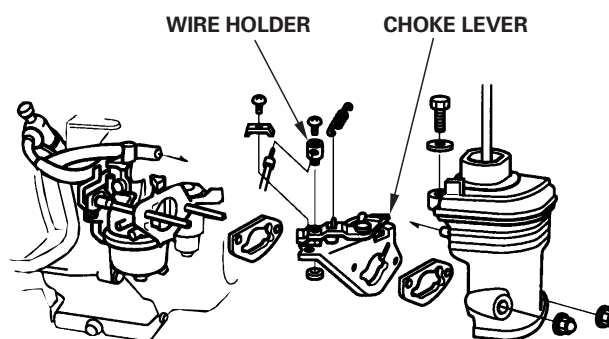
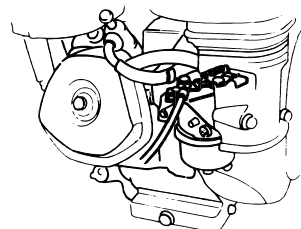



Carburetor Modifications for High Altitude Operation

At high altitude, the standard carburetor air-fuel mixture will be too rich. Performance will decrease, and fuel consumption will increase. A very rich mixture will also foul the spark plug and cause hard starting. Operation at an altitude that differs from that at which this engine was certified, for extended periods of time, may increase emissions.

High altitude performance can be improved by specific modifications to the carburetor. If you always operate your engine at altitudes above 1,500 meters (5,000 feet), have your servicing dealer perform this carburetor modification. This engine, when operated at high altitude with the carburetor modifications for high altitude use, will meet each emission standard throughout its useful life.

Even with carburetor modification, engine horsepower will decrease about 3.5% for each 300-meter (1,000-foot) increase in altitude. The effect of altitude on horsepower will be greater than this if no carburetor modification is made.

NOTICE

When the carburetor has been modified for high altitude operation, the air-fuel mixture will be too lean for low altitude use. Operation at altitudes below 1,500 meters (5,000 feet) with a modified carburetor may cause the engine to overheat and result in serious engine damage. For use at low altitudes, have your servicing dealer return the carburetor to original factory specifications.

Emission Control System Information

Source of Emissions

The combustion process produces carbon monoxide, oxides of nitrogen, and hydrocarbons. Control of hydrocarbons and oxides of nitrogen is very important because, under certain conditions, they react to form photochemical smog when subjected to sunlight. Carbon monoxide does not react in the same way, but it is toxic.

Honda utilizes appropriate air/fuel ratios and other emissions control systems to reduce the emissions of carbon monoxide, oxides of nitrogen, and hydrocarbons. Additionally, Honda fuel systems utilize components and control technologies to reduce evaporative emissions.

The U.S., California Clean Air Acts and Environment Canada

EPA, California and Canadian regulations require all manufacturers to furnish written instructions describing the operation and maintenance of emission control systems.

The following instructions and procedures must be followed in order to keep the emissions from your Honda engine within the emission standards.

Tampering and Altering

Tampering with or altering the emission control system may increase emissions beyond the legal limit. Among those acts that constitute tampering are:

- Removal or alteration of any part of the intake, fuel, or exhaust systems.
- Altering or defeating the governor linkage or speed-adjusting mechanism to cause the engine to operate outside its design parameters.

Problems That May Affect Emissions

If you are aware of any of the following symptoms, have your engine inspected and repaired by your servicing dealer.

- Hard starting or stalling after starting.
- Rough idle.
- Misfiring or backfiring under load.
- Afterburning (backfiring).
- Black exhaust smoke or high fuel consumption.

Replacement Parts

The emission control systems on your Honda engine were designed, built, and certified to conform with EPA, California (models certified for sale in California), and Canadian emission regulations. We recommend the use of Honda Genuine parts whenever you have maintenance done. These original-design replacement parts are manufactured to the same standards as the original parts, so you can be confident of their performance. The use of replacement parts that are not of the original design and quality may impair the effectiveness of your emission control system.

A manufacturer of an aftermarket part assumes the responsibility that the part will not adversely affect emission performance. The manufacturer or rebuilder of the part must certify that use of the part will not result in a failure of the engine to comply with emission regulations.

Maintenance

Follow the maintenance schedule on page 7. Remember that this schedule is based on the assumption that your machine will be used for its designed purpose. Sustained high-load or high-temperature operation, or use in unusually wet or dusty conditions, will require more frequent service.



**Air Index**

(Models certified for sale in California)

An Air Index Information label is applied to engines certified to an emission durability time period in accordance with the requirements of the California Air Resources Board.

The bar graph is intended to provide you, our customer, the ability to compare the emissions performance of available engines. The lower the Air Index, the less pollution.

The durability description is intended to provide you with information relating to the engine's emission durability period. The descriptive term indicates the useful life period for the engine's emission control system. See your *Emission Control System Warranty* for additional information.

Descriptive Term	Applicable to Emissions Durability Period
Moderate	50 hours (0 – 80 cc, inclusive) 125 hours (greater than 80 cc)
Intermediate	125 hours (0 – 80 cc, inclusive) 250 hours (greater than 80 cc)
Extended	300 hours (0 – 80 cc, inclusive) 500 hours (greater than 80 cc) 1,000 hours (225 cc and greater)

Specifications**GX240/GX270 (PTO shaft type S, with fuel tank)**

Length × Width × Height	355 × 430 × 422 mm (14.0 × 16.9 × 16.6 in)	
Dry mass [weight]	25.0 kg (55.1 lbs)	
Engine type	4-stroke, overhead valve, single cylinder	
Displacement [Bore × Stroke]	GX240	242 cm ³ (14.8 cu-in) [73.0 × 58.0 mm (2.9 × 2.3 in)]
	GX270	270 cm ³ (16.5 cu-in) [77.0 × 58.0 mm (3.0 × 2.3 in)]
Net power (in accordance with SAE J1349*)	GX240	5.3 kW (7.2 PS, 7.1 bhp) at 3,600 rpm
	GX270	6.0 kW (8.2 PS, 8.0 bhp) at 3,600 rpm
Max. Net torque (in accordance with SAE J1349*)	GX240	15.3 N·m (1.56 kgf·m, 11.3 lbf·ft) at 2,500 rpm
	GX270	17.7 N·m (1.80 kgf·m, 13.1 lbf·ft) at 2,500 rpm
Engine oil capacity	1.1 L (1.2 US qt, 1.0 Imp qt)	
Fuel tank capacity	5.3 L (1.40 US gal, 1.17 Imp gal)	
Cooling system	Forced air	
Ignition system	Transistor magneto	
PTO shaft rotation	Counterclockwise	

GX340/GX390 (PTO shaft type S, with fuel tank)

Length × Width × Height	380 × 450 × 447 mm (15.0 × 17.7 × 17.6 in)	
Dry mass [weight]	31.5 kg (69.4 lbs)	
Engine type	4-stroke, overhead valve, single cylinder	
Displacement [Bore × Stroke]	GX340	337 cm ³ (20.6 cu-in) [82.0 × 64.0 mm (3.2 × 2.5 in)]
	GX390	389 cm ³ (23.7 cu-in) [88.0 × 64.0 mm (3.5 × 2.5 in)]
Net power (in accordance with SAE J1349*)	GX340	7.1 kW (9.7 PS, 9.5 bhp) at 3,600 rpm
	GX390	8.2 kW (11.1 PS, 11.0 bhp) at 3,600 rpm
Max. Net torque (in accordance with SAE J1349*)	GX340	22.1 N·m (2.25 kgf·m, 16.3 lbf·ft) at 2,500 rpm
	GX390	25.1 N·m (2.56 kgf·m, 18.5 lbf·ft) at 2,500 rpm
Engine oil capacity	1.1 L (1.2 US qt, 1.0 Imp qt)	
Fuel tank capacity	6.1 L (1.61 US gal, 1.34 Imp gal)	
Cooling system	Forced air	
Ignition system	Transistor magneto	
PTO shaft rotation	Counterclockwise	

* The power rating of the engine indicated in this document is the net power output tested on a production engine for the engine model and measured in accordance with SAE J1349 at 3,600 rpm (Net Power) and at 2,500 rpm (Max. Net Torque). Mass production engines may vary from this value. Actual power output for the engine installed in the final machine will vary depending on numerous factors, including the operating speed of the engine in application, environmental conditions, maintenance, and other variables.



**Tuneup Specifications GX240/GX270/GX340/GX390**

ITEM	SPECIFICATION	MAINTENANCE
Spark plug gap	0.7–0.8 mm (0.028–0.031 in)	Refer to page: 12
Idle speed	1,400 ± 150 rpm	Refer to page: 13
Valve clearance (cold)	IN: 0.15 ± 0.02 mm EX: 0.20 ± 0.02 mm	See your authorized Honda dealer
Other specifications	No other adjustments needed.	

Quick Reference Information

Fuel	Unleaded gasoline (Refer to page 8)	
	U.S.	Pump octane rating 86 or higher
	Except U.S.	Research octane rating 91 or higher Pump octane rating 86 or higher
Engine oil	SAE 10W-30, API SJ or later, for general use. Refer to page 8.	
Reduction case oil	Same oil as engine oil, see above (applicable types).	
Spark plug	BPR6ES (NGK) W20EPR-U (DENSO)	
Maintenance	Before each use:	
	<ul style="list-style-type: none"> • Check engine oil level. Refer to page 9. • Check reduction case oil (applicable types). Refer to page 9. • Check air filter. Refer to page 10. 	
	First 20 hours:	
	<ul style="list-style-type: none"> • Change engine oil. Refer to page 9. • Change reduction case oil (applicable types). Refer to page 10. 	
	Subsequent: Refer to the maintenance schedule on page 7.	

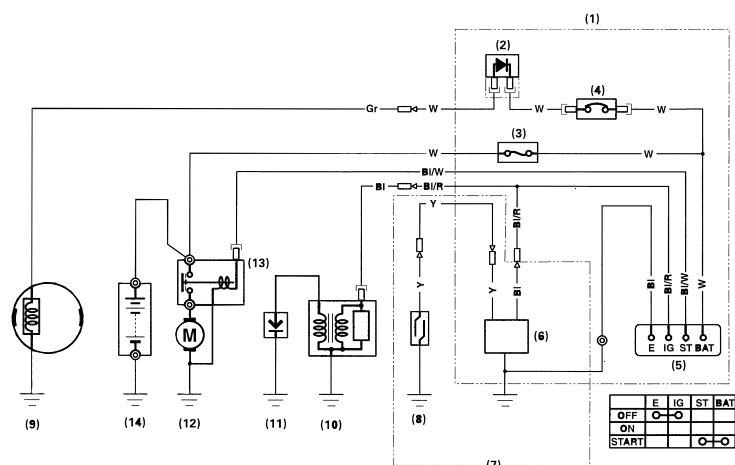
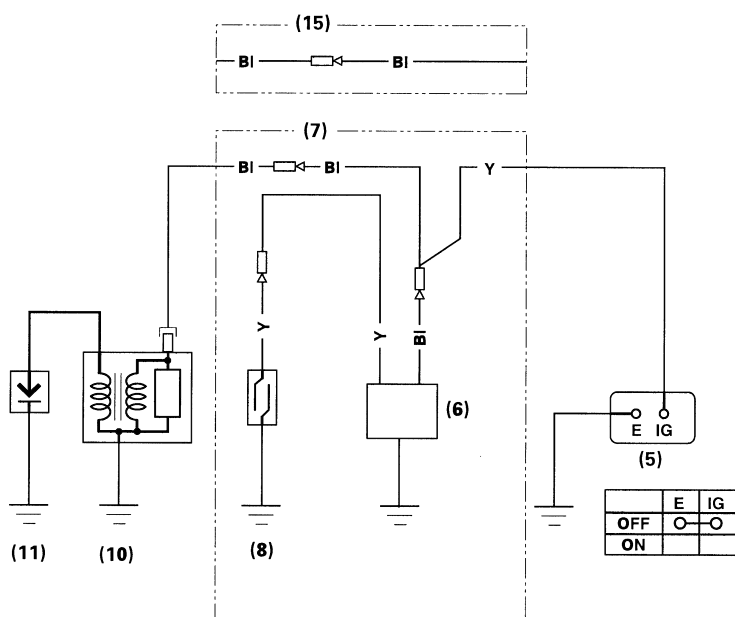
Wiring Diagrams**With Oil Alert and Electric Starter****With Oil Alert and Without Electric Starter**

- | | |
|------------------------------|----------------------------------|
| (1) CONTROL BOX | (9) CHARGING COIL |
| (2) RECTIFIER | (10) IGNITION COIL |
| (3) FUSE | (11) SPARK PLUG |
| (4) CIRCUIT PROTECTOR | (12) STARTER MOTOR |
| (5) ENGINE SWITCH | (13) STARTER SOLENOID |
| (6) OIL ALERT UNIT | (14) BATTERY (12 V) |
| (7) Type with Oil Alert unit | (15) Type without Oil Alert unit |
| (8) OIL LEVEL SWITCH | |

Bl	Black	Br	Brown
Y	Yellow	O	Orange
Bu	Blue	Lb	Light blue
G	Green	Lg	Light green
R	Red	P	Pink
W	White	Gr	Gray



CONSUMER INFORMATION

DISTRIBUTOR/DEALER LOCATOR INFORMATION

United States, Puerto Rico, and U.S. Virgin Islands:

Call (800) 426-7701

or visit our website: www.honda-engines.com

Canada:

Call (888) 9HONDA9

or visit our website: www.honda.ca

For European Area:

Visit our website: <http://www.honda-engines-eu.com>

CUSTOMER SERVICE INFORMATION

Servicing dealership personnel are trained professionals. They should be able to answer any question you may have. If you encounter a problem that your dealer does not solve to your satisfaction, please discuss it with the dealership's management. The Service Manager, General Manager, or Owner can help. Almost all problems are solved in this way.

United States, Puerto Rico, and U.S. Virgin Islands:

If you are dissatisfied with the decision made by the dealership's management, contact the Honda Regional Engine Distributor for your area.

If you are still dissatisfied after speaking with the Regional Engine Distributor, you may contact the Honda Office as shown.

All Other Areas:

If you are dissatisfied with the decision made by the dealership's management, contact the Honda Office as shown.

«Honda's Office»

When you write or call, please provide this information:

- Equipment manufacturer's name and model number that the engine is mounted on
- Engine model, serial number, and type (see page 16)
- Name of dealer who sold the engine to you
- Name, address, and contact person of the dealer who services your engine
- Date of purchase
- Your name, address and telephone number
- A detailed description of the problem

United States, Puerto Rico, and U.S. Virgin Islands:

American Honda Motor Co., Inc.

Power Equipment Division

Customer Relations Office

4900 Marconi Drive

Alpharetta, GA 30005-8847

Or telephone: (770) 497-6400, 8:30 am - 7:00 pm ET

Canada:

Honda Canada, Inc.

715 Milner Avenue

Toronto, ON

M1B 2K8

Telephone: (888) 9HONDA9 Toll free

(888) 946-6329

(416) 299-3400

Local Toronto dialing area

Facsimile: (877) 939-0909 Toll free

(416) 287-4776

Local Toronto dialing area

Australia:

Honda Australia Motorcycle and Power Equipment Pty. Ltd.

1954 – 1956 Hume Highway Campbellfield Victoria 3061

Telephone: (03) 9270 1111

Facsimile: (03) 9270 1133

For European Area:

Honda Europe NV.

European Engine Center

<http://www.honda-engines-eu.com>

All Other Areas:

Please contact the Honda distributor in your area for assistance.



HONDA
The Power of Dreams

